



5-Minute Check

Use with Lesson

1-1

Find the value of each expression.

1. $354 - 24 + 8$

2. $90 + 50 - 49$

3. $4 \times 7 \div 2$

4. $8 \times 6 \div 3 \times 5$

5. A regional manager is ordering puzzles for the 5 toy stores in his region. How many puzzles will each store get if he orders 340 puzzles, and each store receives an equal number of puzzles?

6. **Standardized Test Practice** Gretchen gave 6 apples to John, and now he has 11. How many apples did John start with?

A 4

B 5

C 6

D 7

ANSWERS

1. 338

2. 91

3. 14

4. 80

5. 68 puzzles

6. B



5-Minute Check (over Lesson 1-1)

Use with Lesson

1-2

Use the four-step plan to solve each problem.

1. If a machine that runs 24 hours a day can make 144 toy cars per day, how many toy cars can it make per hour?
2. Katie walked for 2 hours at 3 miles per hour and then biked for 2 hours at 10 miles per hour. How far did she travel altogether?
3. Mrs. Genebe worked all year and earned \$23,400. How much did she earn per week?
4. Four bakers can each make 3 cakes per hour. How many cakes can all 4 bakers make in 2 hours?
5. **Standardized Test Practice** Samuel baked 4 dozen chocolate chip cookies, 3 dozen peanut butter cookies, and 2 dozen sugar cookies. Which expression shows how many cookies Samuel baked?

(A) $(12 + 4) \times (12 + 3) \times (12 + 2)$

(B) $(12 \times 4) + (12 \times 3) + (12 \times 2)$

(C) $(4 \times 3 \times 2) + 12$

(D) $12(4 + 3 + 2)$

ANSWERS

1. 6 toys/hour 2. 26 miles 3. \$450
4. 24 cakes 5. B



5-Minute Check (over Lesson 1-2)

Use with Lesson

1-3

Tell whether each number is divisible by 2, 3, 4, 5, 6, 9, or 10. Then classify each number as even or odd.

- 45
- 12
- 100
- 54
- Can 40 packages be evenly divided among 5 delivery persons? among 6 delivery persons?
- Standardized Test Practice** Which number does *not* divide into 140 evenly?

A 6

B 4

C 7

D 5

ANSWERS

- 3, 5, 9; odd
- 2, 3, 4; even
- 2, 4, 5, 10; even
- 2, 3, 6, 9; even
- 5, yes; 6, no
- A



5-Minute Check (over Lesson 1-3)

Use with Lesson

1-4

Tell whether each number is *prime*, *composite*, or *neither*.

1. 23

2. 57

Find the prime factorization of each number.

3. 60

4. 84

5. What numbers less than 110 contain 5×5 in their prime factorizations?

6. **Standardized Test Practice** Which is the prime factorization of 540?

A $2^3 \times 3^3 \times 5$

B $2^2 \times 3^2 \times 5^2$

C $2^2 \times 3^3 \times 5$

D $2 \times 3^3 \times 5^2$

ANSWERS

1. prime

2. composite

3. $2 \times 2 \times 3 \times 5$

4. $2 \times 2 \times 3 \times 7$

5. 25, 50, 75, 100

6. C



5-Minute Check (over Lesson 1-4)

Use with Lesson

1-5

Write each product using an exponent. Then find the value of the power.

1. $6 \cdot 6 \cdot 6 \cdot 6$

2. $8 \cdot 8 \cdot 8$

Write each power as a product. Then find the value of the product.

3. 5^3

4. 3^6

5. There are 1,024 bytes in a kilobyte. Write this number as a power of 2.

6. **Standardized Test Practice** What is the value of 6^3 ?

ANSWERS

1. 6^4 ; 1,296

2. 8^3 ; 512

3. $5 \cdot 5 \cdot 5$; 125

4. $3 \cdot 3 \cdot 3 \cdot 3 \cdot 3 \cdot 3$; 729

5. 2^{10}

6. 216



5-Minute Check (over Lesson 1-5)

Use with Lesson

1-6

Find the value of each expression.

1. $9 \times 2 + 4$

2. $10 - 3 \times 2$

3. $4^2 + 18 \div 2$

4. $4 + 9 \times 3 - 2$

5. Two adults are taking ten children to the movie theatre. An adult's ticket costs \$7 and a child's ticket costs \$5. Find the cost for all twelve people to go to the movies.

6. **Standardized Test Practice** Which expression is *not* equal to 9?

A $9 + 3 \times 2 - 2^2 - 2$

B $(4^2 + 4) \div 2 - 1$

C $(8 - 2) + 6 \div 2$

D $3 \times (9 - 3)$

ANSWERS

1. 22

2. 4

3. 25

4. 29

5. \$64

6. D



5-Minute Check (over Lesson 1-6)

Use with Lesson

1-7

Evaluate each expression if $a = 2$ and $b = 5$.

1. $8a + 2b$

2. $b - 2a$

3. $6ab \div 12 - 2$

4. $b^3 + a^2$

5. A shelf for bowling balls can support 100 pounds. If a red bowling ball weighs 6 pounds, and a blue bowling ball weighs 10 pounds, can the shelf support 4 red bowling balls and 6 blue bowling balls? Write the total weight of the bowling balls.

6. **Standardized Test Practice** Find the value of $4st - 2t$ if $t = 3$ and $s = 2$.

(A) 18

(B) 24

(C) 20

(D) 12

ANSWERS

1. 26

2. 1

3. 3

4. 129

5. yes; 84 pounds

6. A



5-Minute Check (over Lesson 1-7)

Use with Lesson

1-8

Identify the solution of each equation from the list given.

1. $12 - x = 8$; 2, 4, 6

2. $7 + y = 15$; 2, 6, 8

Solve each equation mentally.

3. $25 = j - 4$

4. $99 + t = 124$

5. Jackie ate 4 cookies, and now there are 13 left. How many did she start with?

6. **Standardized Test Practice** In the equation $30 - a = 13$, a represents the number of students in the accelerated course. How many students are in the accelerated course?

(A) 30

(B) 13

(C) 17

(D) 15

ANSWERS

1. 4

2. 8

3. 29

4. 25

5. 17

6. C



5-Minute Check (over Chapter 1)

Use with Lesson

2-1

1. Find the prime factorization of 120.
2. Write 2^4 as a product and evaluate it.

Solve each equation.

3. $30 - 4 \times 12 \div 3 = x$

4. $24 \div y = 6$

5. Scott has 28 baseball cards. Doug has three more baseball cards than Scott. June has three times as many baseball cards as Doug. How many baseball cards does June have?

6. **Standardized Test Practice** Which number divides 900 and 150?

A 12

B 30

C 90

D 45

ANSWERS

1. $2 \times 2 \times 2 \times 3 \times 5$

2. $2 \times 2 \times 2 \times 2$; 16

3. 14

4. 4

5. 93 baseball cards

6. B



5-Minute Check (over Lesson 2-1)

Use with Lesson

2-2

For Exercise 1, use the frequency table that lists the number of new cars sold at a car dealership.

Cars Sold		
Day	Tally	Frequency
Sunday		4
Monday		5
Tuesday		6
Wednesday		7
Thursday		7
Friday		6
Saturday		2

- If the sales for this week are typical, would the car dealership expect to sell more cars on a weekday or on a weekend day next week?

Make a frequency table for the set of data.

- | Number of Books Read by Students | | | | | |
|----------------------------------|---|---|---|---|---|
| 5 | 5 | 6 | 9 | 6 | 3 |
| 7 | 5 | 7 | 6 | 3 | 6 |

- Standardized Test Practice** What is an appropriate interval and scale to use for a frequency table for the data 3, 17, 3, 8, 4, 14, 7, 19, 1, 6, 9, 11, and 14?

ANSWERS

- weekday
-
- scale, 0 to 20; interval, 5

- | Books Read by Students | |
|------------------------|-----------|
| Books | Frequency |
| 3 | 2 |
| 5 | 3 |
| 6 | 4 |
| 7 | 2 |
| 9 | 1 |



5-Minute Check (over Lesson 2-2)

Use with Lesson

2-3

1. Make a bar graph for the set of data at the right.

Fish Sold	
Month	Frequency
April	4,862
May	5,219
June	2,385
July	8,355

For Exercise 2, use the bar graph made in Exercise 1.

2. In which month were about four times as many fish sold as the number sold in June?

3. Standardized Test Practice

What is the scale of the graph? What is another possible scale?

Drinks Served

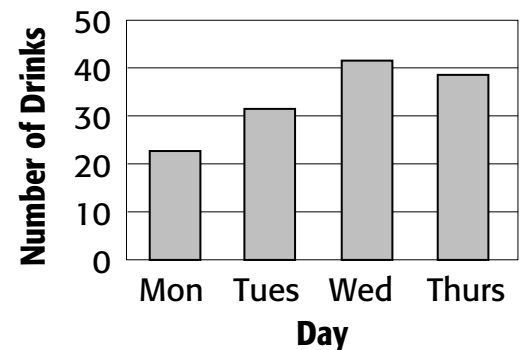

ANSWERS

1.

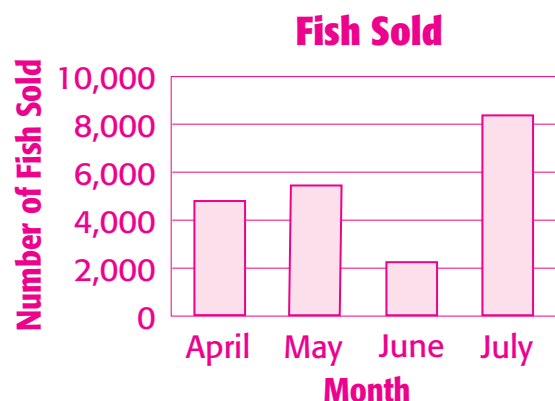

2. July

3. 0–50;

Sample answer: 20–45



For Exercises 1–3, use the graph.

1. On what two activities does Richard spend the most amount of time?
2. On what activity does Richard spend the least amount of time?
3. Does Richard spend more or less time watching TV than playing and doing homework combined?

Richard's Average Day

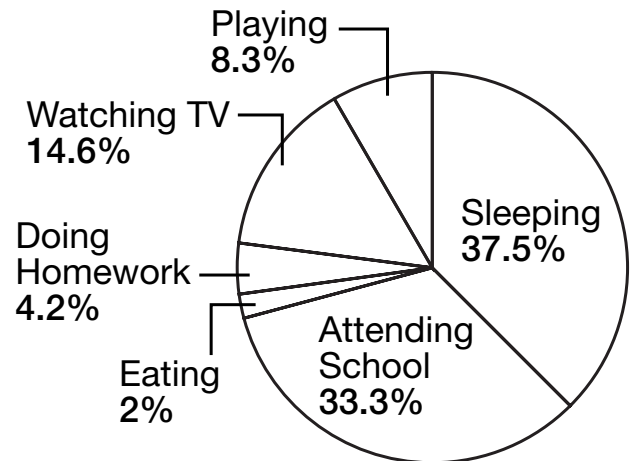

4. **Standardized Test Practice** Which two foods together are chosen the same amount as pizza?

- A pasta & chicken
- B pasta & hamburger
- C home lunch & pasta
- D hamburger & chicken

Lunch Choices

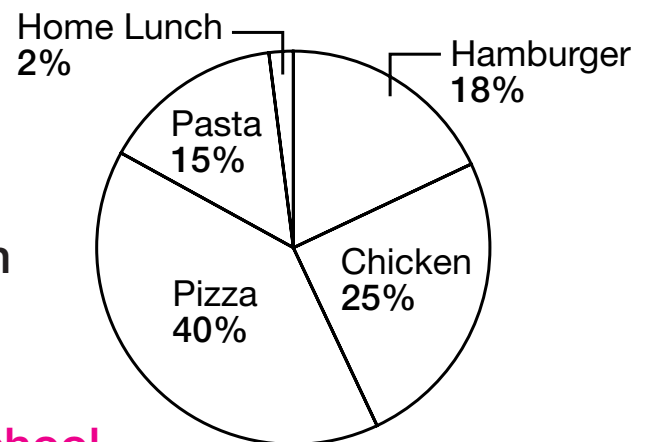

ANSWERS

1. sleeping and attending school
2. eating
3. more
4. A



For Exercises 1–4, use the graph.

1. Based on the trend in the graph, will the enrollment in 2003 be higher or lower than 2002?
2. Based on the trend in the graph, about what will the enrollment be in 2003? in 2004?
3. Based on the graph, about what was the enrollment in 1997?
4. Based on the trend in the graph, about how many years after 2002 will it take to reach an enrollment of 200 students?
5. **Standardized Test Practice**

Based on the trend in the graph, about how many flowers will be on the bush in week 7?

- (A) 40 (B) 35
(C) 60 (D) 45

Students Enrolled

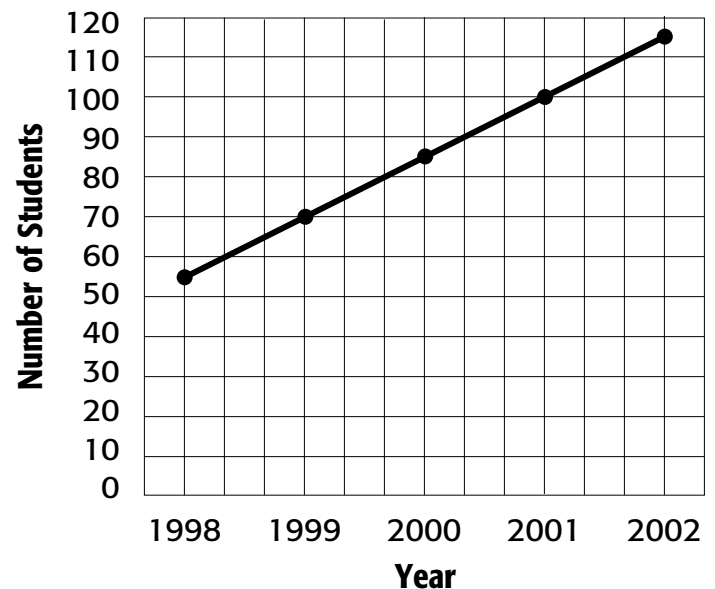

Flowers on a Bush

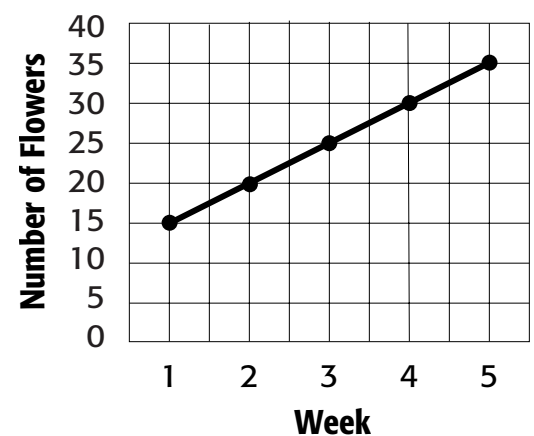

ANSWERS

1. higher 2. 130; 145 3. 40 4. 6 years 5. D



5-Minute Check (over Lesson 2-5)

Use with Lesson

2-6

Make a stem-and-leaf plot for each set of data.

- 28, 27, 15, 23, 15, 22, 25, 33, 19, 11, 25, and 18
- 89, 84, 74, 105, 94, 82, 90, 74, 107, 86, 99, 100, 97, and 71
- In the stem-and-leaf plot you created for Exercise 2 above, what are the least and greatest numbers in the set of data? How many numbers are greater than 85?
- Standardized Test Practice** This stem and leaf plot shows the costs of various video games. Which cost interval contains the fewest games?

- A 40 B 35
 C 60 D 45

Stem	Leaf
3	2 5 9
4	0 5 5 9
5	2 4 4 4 5 7 9
6	5 9

$3|5 = 35$

ANSWERS

1.

Stem	Leaf
1	1 5 5 8 9
2	2 3 5 5 7 8
3	3

$2|5 = 25$

2.

Stem	Leaf
7	1 4 4
8	2 4 6 9
9	0 4 7 9
10	0 5 7

$8|6 = 86$

3. 71 and 107; 9

4. D



5-Minute Check (over Lesson 2-6)

Use with Lesson

2-7

Find the mean for each set of data.

- 2, 2, 6, 10, 20
- 5, 10, 10, 15, 20
- 22, 25, 16, 27, 20
- 66, 73, 97, 36, 84, 16
- Rudi paid \$8 each for six hats. Michelle paid \$10 each for two hats and \$7 each for four hats. Who paid the higher average price per hat? Explain.
- Standardized Test Practice** What is the mean of 13, 18, 9, 12, and 18?
 A 9 B 12 C 14 D 18

ANSWERS

- 8
- 12
- 22
- 62
- They both paid an average price of \$8 per hat, so neither paid more per hat.
- C



5-Minute Check (over Lesson 2-7)

Use with Lesson

2-8

Find the mean, median, mode, and range for each set of data.

- 2, 3, 6, 6, 8
- 8, 16, 24, 32, 32, 44
- 42, 17, 28, 17, 62, 28, 16
- 26, 37, 29, 52, 91, 29
- Which measure best describes the data in Exercise 4? Explain.
- Standardized Test Practice** What is the median of 22, 43, 46, and 39?
 A 44 B 39 C 41 D 43

ANSWERS

- 5; 6; 6; 6
- 26; 28; 32; 36
- 30; 28; 17 and 28; 46
- 44; 33; 29; 65
- The median best represents the data. It is closer to most of the numbers in the data set.
- C



5-Minute Check (over Chapter 2)

Use with Lesson

3-1

1. At a local deli, 7 meals were ordered on Monday, 10 meals were ordered on Tuesday, 6 meals were ordered on Wednesday, and 5 meals were ordered on Thursday. Make a frequency table of the data.
2. Which scale is more appropriate for the data set 18, 15, 27, 12, 37, 27, and 18: 0 to 30 or 0 to 40?
3. Make a stem-and-leaf plot for the data 18, 15, 27, 12, 37, 27, and 18.
4. Use the stem-and-leaf plot you created for Exercise 3 to find the mean, median, and mode of the data.
5. **Standardized Test Practice** What is the mean of 73, 14, 18, 33, and 52?

A 18

B 20

C 38

D 190

ANSWERS

1.

Meals Ordered		
Day	Tally	Frequency
Monday		7
Tuesday		10
Wednesday		6
Thursday		5

2. 0 to 40

3.

Stem	Leaf
1	2 5 8 8
2	7 7
3	7

4. 22; 18; 18 and 27

5. C



5-Minute Check (over Lesson 3-1)

Use with Lesson

3-2

Write each decimal in word form.

1. 12.004
2. 8.37

Write each decimal in standard form and in expanded form.

3. forty-eight thousandths
4. fourteen and five hundred six thousandths
5. Daniel purchased a book for seven dollars and eighty-two cents. Write this amount in standard form.
6. **Standardized Test Practice** Which decimal represents eight thousandths?

A 0.08 B 0.008 C 0.0008 D 0.00008

ANSWERS

1. twelve and four thousandths
2. eight and thirty-seven hundredths
3. 0.048; $(4 \times 0.01) + (8 \times 0.001)$
4. 14.506;
 $(1 \times 10) + (4 \times 1) + (5 \times 0.1) + (6 \times 0.001)$
5. \$7.82
6. B



5-Minute Check (over Lesson 3-2)

Use with Lesson

3-3

Use $>$, $<$, or $=$ to compare each pair of decimals.

1. $4.506 \bullet 4.560$

2. $9.0301 \bullet 9.030100$

Order each set of decimals from greatest to least.

3. $2.73, 3.72, 2.37, 2.703$

4. $0.927, 0.638, 0.374, 0.774, 0.635$

5. Tia worked 4.5 hours on Monday, 4.25 hours on Wednesday, and 4.75 hours on Friday. On which day did she work the least number of hours? On which day did she work the greatest number of hours?

6. **Standardized Test Practice** Which decimal is the greatest?

(A) 9.086

(B) 9.021

(C) 9.001

(D) 9.19

ANSWERS

1. $<$

2. $=$

3. $3.72, 2.73, 2.703, 2.37$

4. $0.927, 0.774, 0.638, 0.635, 0.374$

5. She worked the least number of hours on Wednesday and the greatest number of hours on Friday.

6. D



5-Minute Check (over Lesson 3-3)

Use with Lesson

3-4

Round each decimal to the indicated place-value position.

1. 8.4302; tenths
2. 9.6452; thousandths
3. 1.257; hundredths
4. 8.186172; ten-thousandths
5. 8.239; hundredths
6. **Standardized Test Practice** Round 155.82145 to the nearest hundredth.

- | | | | |
|-------------------------|---------|-------------------------|--------|
| <input type="radio"/> A | 155.83 | <input type="radio"/> B | 200 |
| <input type="radio"/> C | 155.821 | <input type="radio"/> D | 155.82 |

ANSWERS

1. 8.4
2. 9.645
3. 1.26
4. 8.1862
5. 8.24
6. D



5-Minute Check (over Lesson 3-4)

Use with Lesson

3-5

Estimate using rounding.

1. $13.61 + 10.32$
2. $22.58 + 19.62 - 12.28$

Estimate using front-end estimation.

3. $15.82 - 10.93$
4. $103.356 + 77.13$
5. One barrel has 23.18 pounds of potatoes and another barrel has 31.76 pounds of potatoes. About how many pounds of potatoes are in both barrels?
6. **Standardized Test Practice** Estimate $52.315 + 36.215 + 22.19$.

ANSWERS

1. 24
2. 31
3. 5
4. 180
5. about 55 pounds
6. 110



5-Minute Check (over Chapter 3)

Use with Lesson

4-1

Estimate.

1. $6.84 + 5.45$

2. $15.89 - 8.9$

Find the sum or difference.

3. $43.489 + 71.156$

4. $87.49 - 4.239$

5. If an ape at the zoo drank 2.38 gallons of water out of a full five-gallon drum, how much water would be left in the drum?

6. **Standardized Test Practice** What is the sum $7.84 + 38.99$?

A 46.83

B 47.83

C 46.73

D 47.73

ANSWERS

1. 12

2. 7

3. 114.645

4. 83.251

5. 2.62 gal

6. A



Multiply.

1. 1.26
 $\times 4$

2. 8.63
 $\times 7$

3. 9.2×11

4. 3×8.03

5. Allen bought four decks of playing cards. If each deck cost \$1.46, how much did he spend altogether?

6. **Standardized Test Practice** What is the area of the rectangle below?

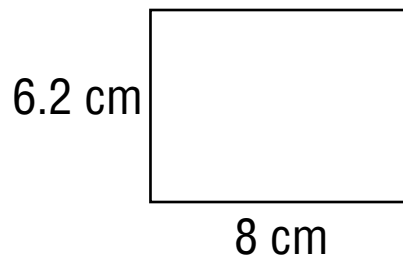

(A) 2.2 cm

(B) 14.6 cm

(C) 49.6 cm

(D) 86.42 cm

ANSWERS

1. 5.04

4. 24.09

2. 60.41

5. 5.84

3. 101.2

6. C



5-Minute Check (over Lesson 4-2)

Use with Lesson

4-3

Multiply.

1. 9.46×3.15

2. 7.01×4.68

Evaluate each expression if $x = 1.25$ and $y = 3.92$.

3. $10.54y$

4. $2x + 8.16$

5. A sprinkler can water 4.5 square feet of lawn per second. How many square feet of lawn can it water in 7.25 seconds?

6. **Standardized Test Practice** What is the area of a rectangular garden that measures 9.5 feet by 8.2 feet?

(A) 17.7 ft^2

(B) 35.4 ft^2

(C) 73.9 ft^2

(D) 77.9 ft^2

ANSWERS

1. 29.799

2. 32.8068

3. 41.3168

4. 10.66

5. 32.625

6. D



5-Minute Check (over Lesson 4-3)

Use with Lesson

4-4

Divide. Round to the nearest tenth if necessary.

1. $10 \overline{)12.89}$

2. $3 \overline{)82.5}$

3. $7.2 \div 6$

4. $4.36 \div 4$

5. If \$7.85 is to be divided equally among 5 people, how much does each person get?

6. **Standardized Test Practice** What is the mean of this set of data? 7.4, 7.1, 3.3, 9.1, 8.2

A 7.1

B 7.05

C 7.01

D 7.02

ANSWERS

1. 1.3

2. 27.5

3. 1.2

4. 1.1

5. \$1.57

6. D



5-Minute Check (over Lesson 4-4)

Use with Lesson

4-5

Divide.

1. $0.2 \overline{)3.8}$

2. $9.3 \div 0.6$

Find each quotient to the nearest hundredth.

3. $0.461 \div 0.19$

4. $0.21 \overline{)0.415}$

5. A truck traveled 93.66 miles on 4.2 gallons of gas. How many miles did the truck travel per gallon of gas?

6. **Standardized Test Practice** What is 69.96 divided by 5.3?

ANSWERS

1. 19

2. 15.5

3. 2.43

4. 1.98

5. 22.3 mpg

6. 13.2



Find the perimeter of each figure.

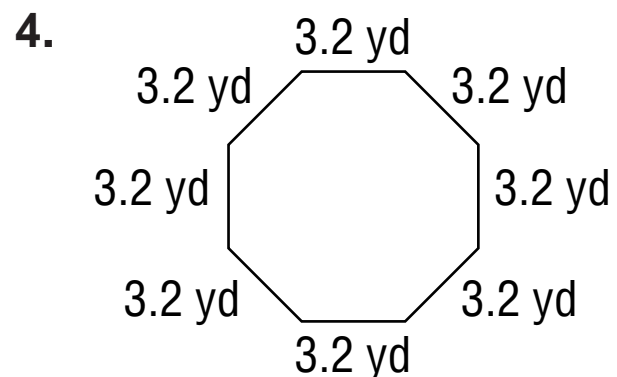
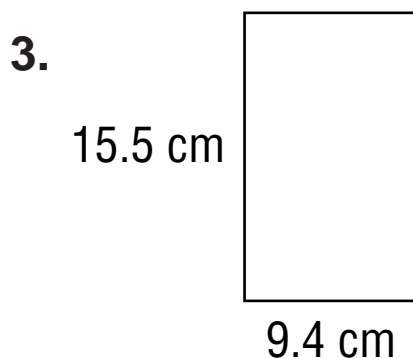
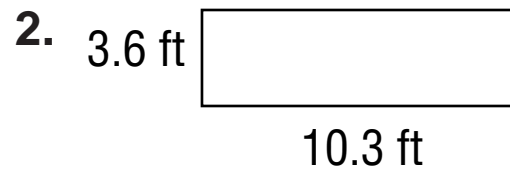
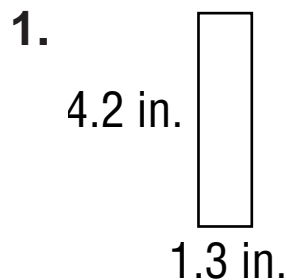

5. What is the perimeter of a rectangular parking lot that measures 52.6 feet by 128.3 feet?

6. **Standardized Test Practice** What is the length of a piece of paper that is 10 inches wide and has a perimeter of 45 inches?

- A 12.5 in. B 17.5 in. C 25 in. D 110 in.

ANSWERS

1. 11 in. 4. 25.6 yd
2. 27.8 ft 5. 361.8 ft
3. 49.8 cm 6. A



5-Minute Check (over Chapter 4)

Use with Lesson

5-1

Multiply or divide.

1. 8.39×6

2. $12.9 \div 4$

3. 3.8×9.25

4. $17.92 \div 5.6$

5. Find the circumference of a circle whose diameter is 2.9 yards. Round to the nearest tenth. Use 3.14 for π .

6. **Standardized Test Practice** Find the value of x :

$$22.36 \div 3.44 \times x.$$

A 6.5

B 5.5

C 7.1

D 6.9

ANSWERS

1. 50.3

2. 3.225

3. 35.15

4. 3.2

5. 9.1 yd

6. A



5-Minute Check (over Lesson 5-1)

Use with Lesson

5-2

Find the GCF of each set of numbers.

- 15 and 21
- 12 and 30
- 15 and 75
- 12, 42, and 60
- 36, 54, and 198
- Standardized Test Practice** Which number can divide 25, 40, and 100?

A 5

B 10

C 15

D 25

ANSWERS

1. 3

2. 6

3. 15

4. 6

5. 18

6. A



5-Minute Check (over Lesson 5-2)

Replace each ● with a number so that the fractions are equivalent.

1. $\frac{1}{2} = \frac{\bullet}{14}$

2. $\frac{12}{19} = \frac{36}{\bullet}$

Write each fraction in simplest form. If the fraction is already in simplest form, write *simplest form*.

3. $\frac{5}{65}$

4. $\frac{8}{36}$

5. Of the 35 students in a class, 28 students passed the last test. Express this fraction in simplest form.

6. **Standardized Test Practice** Write $\frac{180}{900}$ in simplest form.

ANSWERS

1. 7

2. 57

3. $\frac{1}{13}$

4. $\frac{2}{9}$

5. $\frac{4}{5}$

6. $\frac{1}{5}$



5-Minute Check (over Lesson 5-3)

Use with Lesson

5-4

Write each mixed number as an improper fraction.

1. $4\frac{1}{2}$

2. $10\frac{12}{19}$

3. $2\frac{4}{5}$

4. $2\frac{1}{3}$

5. Write $\frac{73}{16}$ as a mixed number.

6. **Standardized Test Practice** Which of the following is equivalent to $\frac{17}{7}$?

A $3\frac{2}{7}$

B $2\frac{4}{7}$

C $2\frac{17}{7}$

D $2\frac{3}{7}$

ANSWERS

1. $\frac{9}{2}$

2. $\frac{202}{19}$

3. $\frac{14}{5}$

4. $\frac{7}{3}$

5. $4\frac{9}{16}$

6. D



5-Minute Check (over Lesson 5-4)

Use with Lesson

5-5

Find the LCM of each set of numbers.

- 2 and 4
- 12 and 8
- 10 and 25
- 14 and 21
- 4, 9, and 12
- Standardized Test Practice** One street light flashes every 6 seconds and another flashes every 4 seconds. If they just flashed at the same time, how many seconds will go by until they flash at the same time again?
 A 4 seconds B 6 seconds
 C 8 seconds D 12 seconds

ANSWERS

- 4
- 24
- 50
- 42
- 36
- D

5-Minute Check (over Lesson 5-5)

Replace each ● with <, >, or = to make a true statement.

1. $\frac{1}{2}$ ● $\frac{2}{3}$

2. $\frac{8}{13}$ ● $\frac{4}{9}$

3. $\frac{6}{13}$ ● $\frac{18}{39}$

Order the fractions from least to greatest.

4. $\frac{5}{12}$, $\frac{2}{9}$, $\frac{7}{8}$, $\frac{6}{13}$

5. $\frac{9}{11}$, $\frac{1}{2}$, $\frac{4}{7}$, $\frac{2}{5}$

6. **Standardized Test Practice** Order the fractions $\frac{1}{4}$, $\frac{6}{7}$, $\frac{4}{5}$, $\frac{3}{8}$, and $\frac{7}{10}$ from greatest to least.

ANSWERS

1. <

2. >

3. =

4. $\frac{2}{9}$, $\frac{5}{12}$, $\frac{6}{13}$, $\frac{7}{8}$

5. $\frac{2}{5}$, $\frac{1}{2}$, $\frac{4}{7}$, $\frac{9}{11}$

6. $\frac{6}{7}$, $\frac{4}{5}$, $\frac{7}{10}$, $\frac{3}{8}$, $\frac{1}{4}$



5-Minute Check (over Lesson 5-6)

Use with Lesson

5-7

Write each decimal as a fraction or mixed number in simplest form.

- 0.75
- 0.375
- 0.4
- 0.83
- A wrench has an opening size of 0.3125 inch. Write this measure as a fraction in simplest form.
- Standardized Test Practice** Which fraction is equivalent to 0.875?

A $\frac{43}{50}$

B $\frac{17}{20}$

C $\frac{7}{8}$

D $\frac{12}{15}$

ANSWERS

1. $\frac{3}{4}$

2. $\frac{3}{8}$

3. $\frac{2}{5}$

4. $\frac{83}{100}$

5. $\frac{5}{16}$ inch

6. C



5-Minute Check (over Chapter 5)

Solve.

1. Find the LCM of 4, 5, and 30.
2. Write $\frac{9}{4}$ as a mixed number.

Replace each ● with a number so that the fractions are equivalent.

3. $\frac{\bullet}{11} = \frac{12}{33}$

4. $\frac{7}{15} = \frac{28}{\bullet}$

5. What is the GCF of 12, 30, and 48?
6. **Standardized Test Practice** Which is $\frac{3}{5}$ written as a decimal?

(A) 0.06

(B) 0.35

(C) 0.60

(D) 3.5

ANSWERS

1. 60
2. $2\frac{1}{4}$
3. 4
4. 60
5. 6
6. C



5-Minute Check (over Lesson 6-1)

Use with Lesson

6-2

Round each number to the nearest half.

1. $4\frac{6}{7}$

2. $\frac{2}{19}$

3. $9\frac{2}{5}$

Tell whether each number should be rounded up or down. Explain your reasoning.

4. the length of wire needed to plug in a lamp $14\frac{1}{5}$ feet away from an outlet

5. the number of files you can save on a CD-ROM

6. **Standardized Test Practice** Round $2\frac{8}{15}$ to the nearest half.

A $1\frac{1}{2}$

B 2

C 3

D $2\frac{1}{2}$

ANSWERS

1. 5

2. 0

3. $9\frac{1}{2}$

4. up; so you will be sure to have enough

5. down; so you will not miss a file

6. D

5-Minute Check (over Lesson 6-2)

Estimate.

1. $3\frac{7}{8} - 1\frac{1}{11}$

2. $4\frac{4}{5} + 9\frac{4}{7}$

3. $1\frac{1}{5} + \frac{9}{10}$

4. $12\frac{8}{11} - 7\frac{5}{9}$

5. Three boxes are $1\frac{1}{8}$, $3\frac{5}{6}$, and $5\frac{6}{11}$ feet tall. About how high would they be if they were stacked on top of one another?

6. **Standardized Test Practice** Estimate the perimeter of a rectangle that is $2\frac{1}{4}$ inches by $4\frac{3}{4}$ inches.

(A) 7 in.

(B) 10 in.

(C) 12 in.

(D) 14 in.

ANSWERS

1. Sample answer: $4 - 1 = 3$

2. Sample answer: $5 + 9\frac{1}{2} = 14\frac{1}{2}$

3. Sample answer: $1 + 1 = 2$

4. Sample answer: $13 - 7\frac{1}{2} = 5\frac{1}{2}$

5. Sample answer: $1 + 4 + 5\frac{1}{2} = 10\frac{1}{2}$ ft

6. D



5-Minute Check (over Lesson 6-3)

Use with Lesson

6-4

Add or subtract. Write in simplest form.

1. $\frac{1}{3} + \frac{2}{3}$

2. $\frac{2}{7} + \frac{6}{7}$

3. $\frac{11}{12} - \frac{7}{12}$

4. $\frac{7}{9} - \frac{4}{9}$

5. How much less than $\frac{9}{11}$ feet is $\frac{1}{11}$ feet?

6. **Standardized Test Practice** What is the sum of $\frac{3}{6}$ and $\frac{5}{6}$?

A $\frac{2}{3}$

B $\frac{8}{12}$

C $1\frac{1}{3}$

D $1\frac{1}{4}$

ANSWERS

1. 1

2. $1\frac{1}{7}$

3. $\frac{1}{3}$

4. $\frac{1}{3}$

5. $\frac{8}{11}$ ft

6. C



5-Minute Check (over Lesson 6-4)

Use with Lesson

6-5

Add or subtract. Write in simplest form.

$$1. \quad \begin{array}{r} \frac{1}{5} \\ - \frac{1}{10} \\ \hline \end{array}$$

$$2. \quad \begin{array}{r} \frac{5}{6} \\ + \frac{3}{12} \\ \hline \end{array}$$

$$3. \quad \begin{array}{r} \frac{1}{4} \\ + \frac{2}{9} \\ \hline \end{array}$$

$$4. \quad \begin{array}{r} \frac{9}{10} \\ - \frac{1}{2} \\ \hline \end{array}$$

5. What is the sum of $\frac{1}{6}$, $\frac{1}{12}$, and $\frac{4}{5}$?

6. **Standardized Test Practice** How much more is $\frac{9}{12}$ ounce than $\frac{3}{8}$ ounce?

ANSWERS

$$1. \quad \frac{1}{10}$$

$$2. \quad 1\frac{1}{12}$$

$$3. \quad \frac{17}{36}$$

$$4. \quad \frac{2}{5}$$

$$5. \quad 1\frac{1}{20}$$

$$6. \quad \frac{3}{8} \text{ oz}$$



5-Minute Check (over Lesson 6-5)

Use with Lesson

6-6

Add or subtract. Write in simplest form.

$$\begin{array}{r} 1. \quad 4\frac{5}{9} \\ - \quad \frac{1}{3} \\ \hline \end{array}$$

$$\begin{array}{r} 2. \quad 6\frac{3}{4} \\ - 3\frac{1}{12} \\ \hline \end{array}$$

$$\begin{array}{r} 3. \quad 11\frac{6}{7} \\ + \quad 4\frac{3}{4} \\ \hline \end{array}$$

4. Find the sum of $2\frac{1}{3}$, $1\frac{1}{4}$, and $5\frac{1}{6}$.

5. **Standardized Test Practice** Akumi is $5\frac{2}{3}$ feet tall. If he stands on a box that is $1\frac{1}{8}$ feet tall, how high will the top of his head be?

(A) $5\frac{19}{24}$ ft

(B) $6\frac{3}{8}$ ft

(C) $6\frac{19}{24}$ ft

(D) 7 ft

ANSWERS

1. $4\frac{2}{9}$

4. $8\frac{3}{4}$

2. $3\frac{2}{3}$

5. C

3. $16\frac{17}{28}$

5-Minute Check (over Chapter 6)

Add or subtract. Write in simplest form.

1. $\frac{1}{12} + \frac{5}{12}$

2. $2\frac{2}{3} + 5\frac{4}{9}$

3. $14\frac{1}{4} - 2\frac{1}{2}$

4. $2\frac{8}{13} - 1\frac{19}{26}$

5. Estimate $4\frac{6}{7} + 2\frac{1}{6}$ to the nearest half.

6. **Standardized Test Practice** A square parking lot has sides $32\frac{1}{4}$ feet long. There is one exit that is 10 feet wide. If someone wanted to fence in the entire parking lot, except for the exit, how long would the fence need to be, in feet?

(A) $22\frac{1}{4}$ ft (B) 99 ft (C) 119 ft (D) 129 ft

ANSWERS

1. $\frac{1}{2}$

2. $8\frac{1}{9}$

3. $11\frac{3}{4}$

4. $\frac{23}{26}$

5. Sample answer: $5 + 2 = 7$

6. C



5-Minute Check (over Lesson 7-1)

Use with Lesson

7-2

Estimate each product.

1. $\frac{3}{5} \times \frac{7}{8}$

2. $\frac{1}{5} \times 32$

3. $\frac{5}{6} \times \frac{1}{13}$

4. $2\frac{1}{3} \times 3\frac{5}{6}$

5. $5\frac{3}{4} \times 2\frac{1}{5}$

6. **Standardized Test Practice** A caterer is preparing meals for a party of 78 guests. If about $\frac{1}{4}$ of the guests want steaks, about how many steaks should the caterer bring?

(A) 20 steaks

(B) 40 steaks

(C) 84 steaks

(D) 240 steaks

ANSWERS

1. Sample answer: $\frac{1}{2} \times 1 = \frac{1}{2}$

2. Sample answer: $\frac{1}{5} \times 30 = 6$

3. Sample answer: $1 \times 0 = 0$

4. Sample answer: $2 \times 4 = 8$

5. Sample answer: $6 \times 2 = 12$

6. A



5-Minute Check (over Lesson 7-2)

Multiply. Write in simplest form.

1. $\frac{2}{3} \times \frac{9}{10}$

2. $\frac{3}{7} \times \frac{4}{11}$

3. $\frac{7}{10} \times \frac{2}{9}$

4. $\frac{7}{8} \times 12$

5. A bag contains 50 pieces of candy. If $\frac{2}{5}$ of the pieces are red, how many pieces are *not* red?

6. **Standardized Test Practice** What is the value of xy if

$$x = \frac{2}{5} \text{ and } y = \frac{3}{4}?$$

ANSWERS

1. $\frac{3}{5}$

2. $\frac{12}{77}$

3. $\frac{7}{45}$

4. $10\frac{1}{2}$

5. 30 pieces

6. $\frac{3}{10}$



5-Minute Check (over Lesson 7-3)

Use with Lesson

7-4

Multiply. Write in simplest form.

1. $\frac{3}{5} \times 10\frac{1}{2}$

2. $2\frac{5}{6} \times 1\frac{3}{11}$

3. $2\frac{4}{5} \times 7\frac{2}{3}$

4. $\frac{11}{12} \times 4\frac{2}{3}$

5. To make a certain type of dress, it takes $2\frac{1}{5}$ yards of material. How many yards of material would it take to make a dozen of those dresses?

6. **Standardized Test Practice** Evaluate cm if $c = 1\frac{3}{4}$ and

$$m = 2\frac{1}{2}.$$

(A) $2\frac{3}{8}$

(B) $3\frac{3}{4}$

(C) $4\frac{1}{3}$

(D) $4\frac{3}{8}$

ANSWERS

1. $6\frac{3}{10}$

2. $3\frac{20}{33}$

3. $21\frac{7}{15}$

4. $4\frac{5}{18}$

5. $26\frac{2}{5}$

6. D



5-Minute Check (over Lesson 7-4)

Use with Lesson

7-5

Find the reciprocal of each number.

1. $\frac{1}{8}$

2. $\frac{2}{11}$

Divide. Write in simplest form.

3. $\frac{1}{6} \div \frac{2}{3}$

4. $\frac{3}{7} \div \frac{9}{10}$

5. Lila has $\frac{4}{10}$ of a mile left to walk. If she walks $\frac{1}{8}$ of a mile per minute, how many more minutes will she be walking?

6. **Standardized Test Practice** If you divide $\frac{7}{12}$ by $\frac{2}{3}$, what is the quotient?

A $\frac{14}{36}$

B $\frac{7}{8}$

C $1\frac{1}{7}$

D $2\frac{4}{7}$

ANSWERS

1. 8

2. $\frac{11}{2}$

3. $\frac{1}{4}$

4. $\frac{10}{21}$

5. $3\frac{1}{5}$ minutes

6. B



5-Minute Check (over Lesson 7-5)

Divide. Write in simplest form.

1. $2\frac{2}{3} \div 1\frac{1}{2}$

2. $3\frac{2}{5} \div \frac{1}{6}$

3. $10\frac{3}{4} \div 7\frac{9}{11}$

4. $4\frac{1}{3} \div 6\frac{5}{6}$

5. Each floor tile is $1\frac{3}{4}$ feet long. How many floor tiles can fit along a hallway that is $10\frac{1}{2}$ feet long?

6. **Standardized Test Practice** $11\frac{1}{9}$ pounds of dirt is evenly distributed among potted plants. If each pot has $\frac{4}{9}$ of a pound of dirt in it, how many pots are there?

(A) 25 pots

(B) 26 pots

(C) 27 pots

(D) 28 pots

ANSWERS

1. $1\frac{7}{9}$

4. $\frac{26}{41}$

2. $20\frac{2}{5}$

5. 6

3. $1\frac{3}{8}$

6. A



5-Minute Check (over Chapter 7)

Describe each pattern. Then find the next two numbers in the sequence.

1. 100, 93, 86, 79, . . .

2. $2, 4\frac{1}{2}, 7, 9\frac{1}{2}, \dots$

Multiply.

3. $\frac{3}{4} \times \frac{5}{6}$

4. $1\frac{2}{5} \times 2\frac{1}{4}$

5. Find the reciprocal of $\frac{2}{9}$.

6. **Standardized Test Practice** If $\frac{1}{4}$ is divided by $\frac{2}{7}$, what is the quotient?

ANSWERS

1. subtract 7; 72, 65

2. add $2\frac{1}{2}$; 12, $14\frac{1}{2}$

3. $\frac{5}{8}$

4. $3\frac{3}{20}$

5. $\frac{9}{2}$

6. $\frac{7}{8}$



5-Minute Check (over Lesson 8-1)

Use with Lesson

8-2

Write an integer to describe each situation.

1. withdrawing \$7 from an account
2. gaining 10 yards

Replace each ● with <, >, or = to make a true sentence.

3. $3 \bullet -3$

4. $-4 \bullet 9$

5. $-2 \bullet -2$

6. **Standardized Test Practice** Order -1 , 6 , 9 , and -8 from least to greatest.

A $-1, 6, -8, 9$

B $9, 6, -1, -8$

C $9, -8, 6, 1$

D $-8, -1, 6, 9$

ANSWERS

1. -7

2. $+10$ or 10

3. $>$

4. $<$

5. $=$

6. D



5-Minute Check (over Lesson 8-2)

Use with Lesson

8-3

Add. Use counters or a number line if needed.

1. $+3 + (+4)$

2. $-2 + (+5)$

3. $-1 + (-6)$

4. $+4 + (-7)$

5. Jared owed his friend \$6. Jared's mother gave him \$9. After Jared pays his friend, how much money will Jared have left?

6. **Standardized Test Practice** Find the next number in the sequence 30, 20, 10, 0, . . .

A 40

B -1

C -20

D -10

ANSWERS

1. 7

2. 3

3. -7

4. -3

5. \$3

6. D



5-Minute Check (over Lesson 8-3)

Use with Lesson

8-4

Subtract. Use counters or a number line.

1. $9 - 3$

2. $8 - (-2)$

3. $-7 - (-12)$

4. $-10 - 8$

5. Ninety-five people go into a museum, and 78 go out. How many people are still inside the museum?

6. **Standardized Test Practice** When Joshua went to sleep it was 2° F outside. During the night, the temperature dropped 11° F. What was the temperature outside when he woke up?

- A -9° F B 9° F C -13° F D 13° F

ANSWERS

1. 6

2. 10

3. 5

4. -18

5. 17 people

6. A



5-Minute Check (over Lesson 8-4)

Use with Lesson

8-5

Multiply.

1. 7×9

2. $5(-6)$

3. $-4(-8)$

4. $6 \times (-8)$

5. Find the product of 3 and -7 .

6. **Standardized Test Practice** What is the value of mn if $m = 6$ and $p = -9$?

A -54

B -15

C -3

D 54

ANSWERS

1. 63

2. -30

3. 32

4. -48

5. -21

6. A



5-Minute Check (over Lesson 8-5)

Use with Lesson

8-6

Divide.

- $42 \div 6$
- $36 \div (-9)$
- $-28 \div (-4)$
- $-56 \div 7$
- The Northwood High School football team lost a total of 36 yards in 6 plays. If they lost the same number of yards on each play, what integer gives the number of yards they lost on each play?
- Standardized Test Practice** What value of h makes $-144 \div h = -12$ true?
 A -132 B -12 C 12 D 132

ANSWERS

- 7
- -4
- 7
- -8
- -6
- C



For Exercises 1-2, use the coordinate plane at the right.

1. Identify the point for $(2, 3)$.
2. Write the ordered pair that names point B. Then identify the quadrant where point B is located.

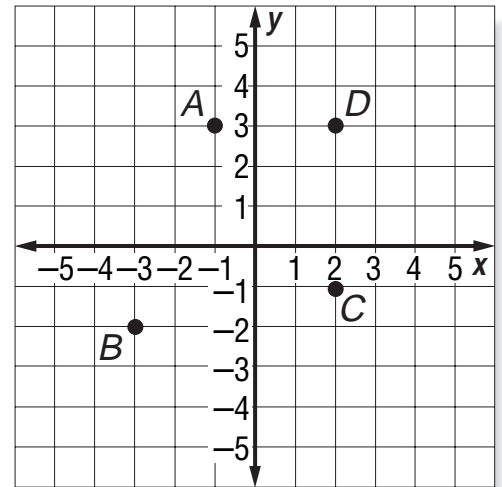

Solve.

3. $+9 + (-11)$
4. $-7 - 3$
5. Find the value of hk if $h = -6$ and $k = -7$.
6. **Standardized Test Practice** What is the value of $m \div n$ if $m = -24$ and $n = 3$.

ANSWERS

1. D
2. $(-3, -2)$; III
3. -2
4. -10
5. 42
6. -8



5-Minute Check (over Lesson 9-1)

Use with Lesson

9-2

Find each product mentally. Use the Distributive Property.

1. 37×6

2. 22×8

Rewrite the expression using the Distributive Property. Then evaluate.

3. $3(40 + 8)$

Identify the property shown by the equation.

4. $4(12 \times 7) = (4 \times 12)7$

5. The toll to cross a bridge is \$1 for cars, \$2 for trucks, and \$3 for vans. If three of each type wanted to cross the bridge, what would the total cost be?

6. **Standardized Test Practice** Which expression is equivalent to $4 \times (3 \times 17)$?

(A) $3 + (4 \times 17)$

(B) $4 \times (3 + 17)$

(C) $3 \times (4 \times 17)$

(D) $4 \times 3 + 4 \times 17$

ANSWERS

1. 222

2. 176

3. $3(40) + 3(8)$; 144

4. Associative Property of Multiplication

5. $3(\$1 + \$2 + \$3) = \18

6. C



5-Minute Check (over Lesson 9-2)

Use with Lesson

9-3

Solve each equation. Use models if necessary. Check your solution.

1. $4 + x = 12$

2. $9 + y = -8$

3. $4 = g + (-2)$

4. $13 + u = 4$

5. Candice has \$75 in her savings account. She got money for her birthday and deposited it into her savings account. Now she has \$150 in her savings account. Write an equation to find how much money Candice got for her birthday.

6. **Standardized Test Practice** Find the value of x in the equation $4 + x = -2$?

A -6

B 2

C 4

D 6

ANSWERS

1. 8

2. -17

3. 6

4. -9

5. $\$75 + c = \150 ; $\$75$

6. A



5-Minute Check (over Lesson 9-3)

Use with Lesson

9-4

Solve each equation. Use models if necessary. Check your solution.

1. $t - 4 = 3$

2. $u - 3 = -1$

3. $-1 = q - 2$

4. $p - 7 = 4$

5. Mrs. Bradford lost \$15 from her purse. If she now has \$35, how much did she have before she lost \$15?

6. **Standardized Test Practice** If $c - 21 = 7$, what is the value of c ?

ANSWERS

1. 7

2. 2

3. 1

4. 11

5. \$50

6. 28



5-Minute Check (over Lesson 9-4)

Use with Lesson

9-5

Solve each equation. Use models if necessary.

1. $4n = 28$

2. $5s = -25$

3. $-3y = -21$

4. $-2k = 6$

5. Keith's mother is twice as old as Keith. If Keith's Mother is 40, how old is Keith?

6. **Standardized Test Practice** Terrence weighs 3 times as much as his dog. If Terrence weighs 90 pounds, how much does his dog weigh?

A 20 pounds

B 30 pounds

C 270 pounds

D 300 pounds

ANSWERS

1. 6

2. -5

3. 7

4. -3

5. 20 years old

6. B



5-Minute Check (over Lesson 9-5)

Solve each equation. Use models if necessary.

1. $3 + 4r = 11$

2. $-19 = 5k + 6$

3. $7w + 1 = 8$

4. $9z - 4 = 32$

5. Four times a number plus 10 is twenty-two. What is the number?

6. **Standardized Test Practice** Beverly has three times as much money as Jordan. Beverly found eight more dollars. If she has 53 dollars now, how much money does Jordan have? Set up an equation and solve.

ANSWERS

1. 2

2. -5

3. 1

4. 4

5. 3

6. \$15



5-Minute Check (over Lesson 9-6)

Use with Lesson

9-7

Complete each function table.

1.

input (x)	output ($x + 3$)
0	<input type="checkbox"/>
3	<input type="checkbox"/>
7	<input type="checkbox"/>

2.

input (x)	output ($2x$)
-2	<input type="checkbox"/>
5	<input type="checkbox"/>
13	<input type="checkbox"/>

Find the rule for the function table.

3.

input (x)	<input type="checkbox"/>
6	3
8	4
10	5

4.

input (x)	<input type="checkbox"/>
1	-2
3	0
4	1

5. **Standardized Test Practice** If a function rule is $3x - 1$, what is the output for an input of 5?

ANSWERS

1. 3, 6, 10

2. -4, 10, 26

3. $\frac{x}{2}$

4. $x - 3$

5. 14



Make a function table for the given rule and input values. Then graph the function.

1. $y = x + 2$; $-2, 1, 3$

Solve each equation. Check your solution.

2. $9 + t = 11$

3. $r - 3 = 17$

4. $3m = 39$

5. $2d + 2 = 12$

6. **Standardized Test Practice** If $y(1) = 4$, $y(0) = 3$, and $y(-1) = 2$, what is the function $y(n)$?

A $3n$

B $4n$

C $3 - n$

D $n + 3$

ANSWERS

1.

x	$x + 2$
-2	0
1	3
3	5

2. 2

3. 20

4. 13

5. 5

6. **D**

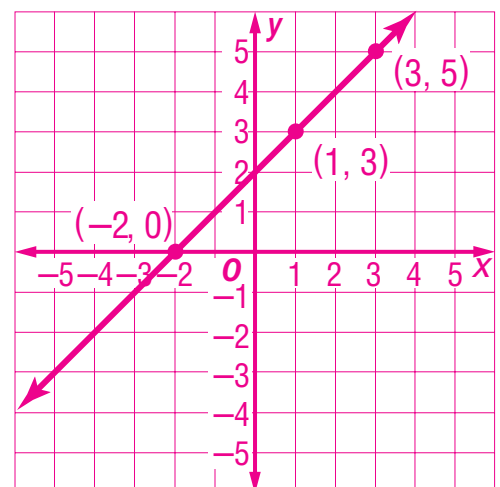



Write each ratio as a fraction in simplest form.

1. 12 apples to 8 oranges
2. 30 chocolate candies to 100 candies

Write each ratio as a unit rate.

3. 8 rolls for \$1.76
4. 325 miles in 5 hours
5. 200 words in 5 minutes
6. **Standardized Test Practice** Adam has 52 pennies and Stephen has 130 pennies. Write the ratio of Adam's pennies to Stephen's pennies as a fraction in simplest form.

ANSWERS

1. $\frac{3}{2}$
2. $\frac{3}{10}$
3. $\frac{\$0.22}{1 \text{ roll}}$
4. $\frac{65 \text{ miles}}{1 \text{ hour}}$
5. $\frac{40 \text{ words}}{1 \text{ minute}}$
6. $\frac{2}{5}$



5-Minute Check (over Lesson 10-2)

Use with Lesson

10-3

Solve each proportion.

1. $\frac{1}{2} = \frac{x}{12}$

2. $\frac{3}{11} = \frac{6}{x}$

3. $\frac{7}{35} = \frac{x}{5}$

4. $\frac{x}{70} = \frac{3}{10}$

5. A customer can get 2 dollars off for every 5 coupons he brings to the store. If he has 15 coupons, how many dollars off does he get?

6. **Standardized Test Practice** What is the solution of

$$\frac{4}{17} = \frac{12}{x}?$$

(A) 2.8

(B) 5.7

(C) 7.25

(D) 51

ANSWERS

1. 6

2. 22

3. 1

4. 21

5. \$6

6. D



For Exercises 1–4, use the following information.

On a scale model of a house, the scale is 1 inch = 20 feet. Find the actual measurements.

	Object	Model Measurement
1.	length of the pool	4 inches
2.	width of the pool	1.5 inches
3.	width of the walkway	$\frac{1}{4}$ inch
4.	length of the back fence	1 foot

5. A model of a paddleboat has a length of 4 feet. If the scale is 2 feet = 13 feet, what is the actual length of the paddleboat?

6. **Standardized Test Practice** An artist made a scale model of a statue. If the scale is 3 inches = 1 foot and the actual height is 12 feet tall, how tall is the model?

(A) 63 inches

(B) 3 feet

(C) 6.5 feet

(D) 30 inches

ANSWERS

1. 80 feet

2. 30 feet

3. 5 feet

4. 240 feet

5. 26 feet

6. B



5-Minute Check (over Lesson 10-4)

Use with Lesson

10-5

Identify each percent modeled.

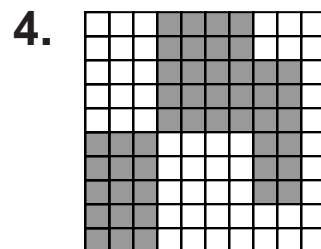
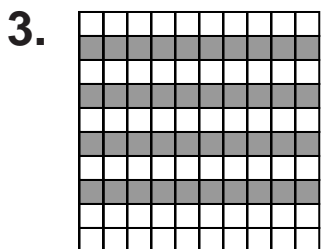
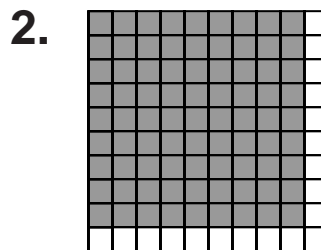
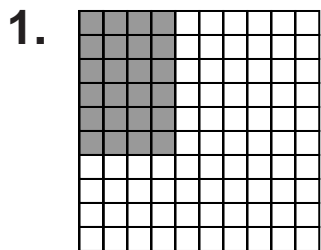

5. Model 65%.

6. **Standardized Test Practice** What percentage of the graph is not shaded?

A 36%

B 64%

C 70%

D 74%

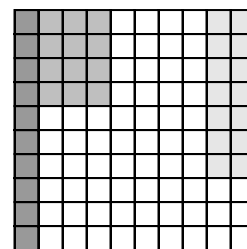

ANSWERS

1. 24%

2. 81%

3. 40%

4. 47%

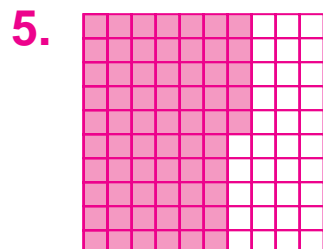

6. B



5-Minute Check (over Lesson 10-5)

Use with Lesson

10-6

Write each percent as a fraction in simplest form.

1. 30%

2. 72%

Write each fraction as a percent.

3. $\frac{2}{5}$

4. $\frac{9}{10}$

5. What percent of a dollar is a quarter?

6. **Standardized Test Practice** Write *seventy-five percent* as a fraction in simplest form.

ANSWERS

1. $\frac{3}{10}$

2. $\frac{18}{25}$

3. 40%

4. 90%

5. 25%

6. $\frac{3}{4}$



5-Minute Check (over Lesson 10-6)

Use with Lesson

10-7

Express each percent as a decimal.

1. 15%
2. 8%

Express each decimal as a percent.

3. 0.3
4. 0.55
5. Write *three and one hundredths* as a percent.
6. **Standardized Test Practice** Which of the following is 220% written as a decimal?

A 0.202 B 0.22 C 2.02 D 2.2

ANSWERS

1. 0.15
2. 0.08
3. 30%
4. 55%
5. 301%
6. D



5-Minute Check (over Lesson 10-7)

Use with Lesson

10-8

Find the percent of each number.

- 20% of 50
- 65% of 34
- 25% of 200
- 80% of 75
- A truck has 85% of its gas left. If it started with a full tank of 25 gallons, how much gas is left?
- Standardized Test Practice** What is 30% of 450?
 A 90 B 120 C 135 D 150

ANSWERS

- 10
- 22.1
- 50
- 60
- 21.25 gallons
- C



5-Minute Check (over Chapter 10)

Use with Lesson

11-1

Solve each proportion.

1. $\frac{2}{5} = \frac{6}{x}$

2. $\frac{3}{7} = \frac{x}{21}$

Find the percent of each number.

3. 25% of 80

4. 65% of 90

5. The winning quilt in a quilting contest had different colors of squares. There were three blue, five red, nine white, seven black, and six green squares. What fraction of the colors starts with the letter “B”? Write the fraction as a percent rounded to the nearest tenth.

6. **Standardized Test Practice** Estimate 31% of 75.

(A) 22.5

(B) 23.25

(C) 24

(D) 26.26

ANSWERS

1. 15

2. 9

3. 20

4. 58.5

5. $\frac{1}{3}$, 33.3%

6. A



5-Minute Check (over Lesson 11-1)

Use with Lesson

11-2

A ten-sided number cube with the numbers 1-10 on it is rolled. Find the probability of each event. Write each answer as a fraction, a decimal, and a percent.

1. $P(3)$
2. $P(1 \text{ or } 2)$
3. $P(4 \text{ or less})$
4. $P(\text{not a multiple of } 3)$
5. A petting zoo has five goats, four camels, and a ferret. If the zookeeper knows that only one animal got out and all animals had an equal chance of getting out, what is the chance that it was the ferret? Write the answer as a fraction, a decimal, and a percent.
6. **Standardized Test Practice** What is the chance of drawing any king in a deck of 52 cards?

A $\frac{1}{52}$

B $\frac{1}{26}$

C $\frac{1}{13}$

D $\frac{1}{10}$

ANSWERS

1. $\frac{1}{10}$, 0.10, 10%

2. $\frac{1}{5}$, 0.20, 20%

3. $\frac{2}{5}$, 0.40, 40%

4. $\frac{7}{10}$, 0.70, 70%

5. $\frac{1}{10}$, 0.10, 10%

6. C



Determine whether each sample is a good sample. Explain.

1. A person at a restaurant is asked her favorite type of soda.
2. A section in a football stadium is asked their favorite sport.

For Exercises 3 and 4, use the following information. In baseball, Tina had 3 hits in her last 10 times at bat.

3. Based on Tina's last 10 at bats, find the probability that Tina will get a hit the next time she is at bat.
4. Suppose Tina is up to bat 30 times. About how many times will she get a hit, based on her last 10 at bats?
5. **Standardized Test Practice** If eight out of ten people prefer tea to water, how many of the next 25 people will want water?

ANSWERS

1. Sample answer: This is a bad sample because only one person was surveyed.
2. Sample answer: This is a bad sample because the group is not selected at random.
3. $\frac{3}{10}$, 0.30, 30%
4. 9
5. 5



5-Minute Check (over Lesson 11-4)

Use with Lesson

11-5

Find the probability that a randomly thrown dart will land in the shaded region of each dartboard.

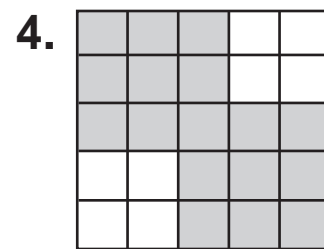
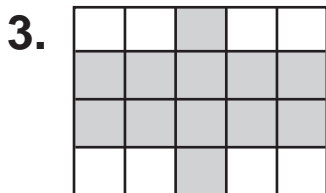
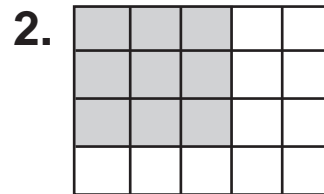
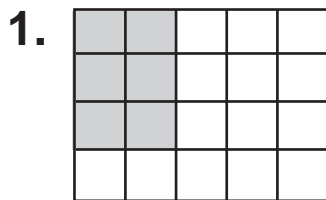

5. It is equally likely that a spaceship will land anywhere in a 10 mile by 10 mile square region. What is the probability that it will land in a 1 square mile target area in that region?
6. **Standardized Test Practice** At a fair, you must throw a ball into a blue jar to win. Only one out of every four balls will go in any jar. If 10 of the 50 jars are blue, what are your chances of winning with one ball?

A 5%

B 20%

C 25%

D 80%

ANSWERS

1. 30%

2. 45%

3. 60%

4. 68%

5. $\frac{1}{100}$, 0.01, 1%

6. A



5-Minute Check (over Chapter 11)

Use with Lesson

12-1

Find the probability of each event. Write each answer as a fraction, a decimal, and a percent.

1. When rolling a number cube, $P(1, 2, \text{ or } 6)$
2. When tossing two coins, $P(\text{both heads})$

For Exercises 3–5, use the following information. One out of every four vehicles sold by a car company is red.

3. Out of 100 cars sold, how many will be red?
4. How many cars should not be red in a shipment of 500 cars to a dealership?
5. **Standardized Test Practice** One half of all computers sold by XYZ company are sold with a DVD drive. If half of the people that buy computers from XYZ company will put games on those computers, what are the chances that someone's computer from XYZ company will have a DVD drive and games on it?

A 25% B 50% C 75% D 100%

ANSWERS

1. $\frac{1}{2}$, 0.50, 50%
2. $\frac{1}{4}$, 0.25, 25%
3. 25
4. 375
5. A



5-Minute Check (over Lesson 12-1)

Use with Lesson

12-2

Complete.

1. 60 in. = ? ft
2. 5 yd = ? in.

Solve.

3. Which is greater: 3 feet or 40 inches?
4. Which is greater: 2 yards or 60 inches?
5. Which is greater: 7 feet or 2 yards?
6. **Standardized Test Practice** Choose the shortest measurement.

A 3 ft

B 2 yd

C $\frac{7}{8}$ yd

D 38 in.

ANSWERS

1. 5
2. 180
3. 40 inches
4. 2 yards
5. 7 feet
6. C



5-Minute Check (over Lesson 12-2)

Use with Lesson

12-3

Complete.

1. $16 \text{ fl oz} = \underline{\quad} \text{ pt}$
2. $1 \text{ qt} = \underline{\quad} \text{ c}$
3. $7 \text{ T} = \underline{\quad} \text{ lb}$

Solve.

4. How many fluid ounces are in three cups?
5. How many quarts are in a five gallon bottle of water?
6. **Standardized Test Practice** A pond has 5,000 gallons of water in it. If the pond loses 1 quart of water per minute due to evaporation, how many minutes will it be before the pond is empty?

ANSWERS

1. 1
2. 4
3. 14,000
4. 24 fl oz
5. 20 qt
6. 20,000 minutes



5-Minute Check (over Lesson 12-3)

Use with Lesson

12-4

Write the metric unit of length that you would use to measure each of the following.

1. length of a football field
2. thickness of a piece of glass
3. width of a piece of paper

Solve.

4. Which is greater: 500 meters or 1 kilometer?
5. Which metric unit of measure is likely to be on a highway distance sign?
6. **Standardized Test Practice** What is the best estimate of the length of a hallway?

A 5 millimeters

B 5 centimeters

C 5 meters

D 5 kilometers

ANSWERS

1. meter

2. millimeter

3. centimeter

4. 1 km

5. kilometers

6. C



5-Minute Check (over Lesson 12-4)

Use with Lesson

12-5

Write the metric unit of mass or capacity that you would use to measure each of the following. Then estimate the mass or capacity.

1. an adult
2. a large goldfish bowl
3. an apple
4. a spoonful of medicine
5. For the same amount of money, you can buy a 1,348-milliliter bottle of water or a $1\frac{1}{2}$ -liter bottle. Which would you buy and why?
6. **Standardized Test Practice** What is the approximate mass of a 20-pound television?

<input type="radio"/> A	5 grams	<input type="radio"/> B	1 kilogram
<input type="radio"/> C	10 kilograms	<input type="radio"/> D	500 grams

ANSWERS

1. kilograms; 80 kg
2. liters; 10 L
3. grams; 200 g
4. milliliters; 5 mL
5. The $1\frac{1}{2}$ liter bottle is larger for the same price.
6. C



5-Minute Check (over Lesson 12-5)

Use with Lesson

12-6

Complete.

1. $20 \text{ m} = \underline{\quad} \text{ km}$
2. $100 \text{ L} = \underline{\quad} \text{ mL}$
3. $45 \text{ mg} = \underline{\quad} \text{ g}$
4. $0.3 \text{ km} = \underline{\quad} \text{ m}$
5. The nearest town is 4.5 km away. How far is that in meters?
6. **Standardized Test Practice** A truck weighs 6,000 kg. How many grams does the truck weigh?

<input type="radio"/> A 60,000	<input type="radio"/> B 600,000
<input type="radio"/> C 6,000,000	<input type="radio"/> D 60,000,000

ANSWERS

1. 0.02
2. 100,000
3. 0.045
4. 300
5. 4,500 meters
6. C



5-Minute Check (over Chapter 12)

Use with Lesson

13-1

Complete.

1. $6 \text{ ft} = \underline{\quad} \text{ yards}$
2. $9 \text{ meters} = \underline{\quad} \text{ cm}$

Solve.

3. What metric unit of measurement would you use to measure the length of an ant?
4. Which is greater: 3 yards or 120 inches?
5.
$$\begin{array}{r} 16 \text{ min } 36 \text{ s} \\ + 8 \text{ min } 27 \text{ s} \\ \hline \end{array}$$

6. **Standardized Test Practice** Find the longest distance.

A 5 m

B 0.01 km

C 5,000 cm

D 10,000 mm

ANSWERS

1. 2
2. 900
3. mm
4. 120 inches
5. 25 min 3 s
6. C



Use a protractor to find the measure of each angle. Then classify each angle as *acute*, *obtuse*, *right*, or *straight*.

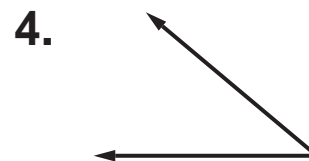
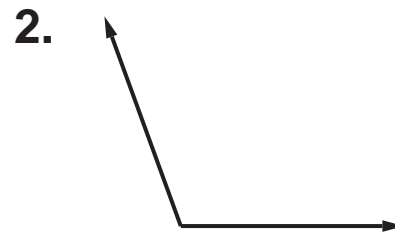
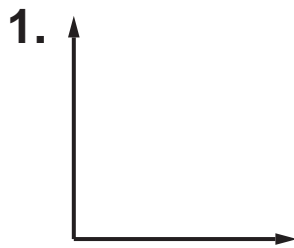

5. If $m\angle A = 32^\circ$ and $\angle A$ and $\angle B$ are supplementary, what is $m\angle B$? If $\angle A$ and $\angle Z$ are complementary, what is $m\angle Z$?

6. **Standardized Test Practice** Which term best describes two angles that measure 54° and 36° ?

A acute

B right

C complementary

D supplementary

ANSWERS

1. 90° ; right

2. 110° ; obtuse

3. 180° ; straight

4. 50° ; acute

5. 148° ; 58°

6. C



5-Minute Check (over Lesson 13-2)

Use with Lesson

13-3

Estimate the measure of each angle.

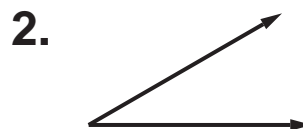
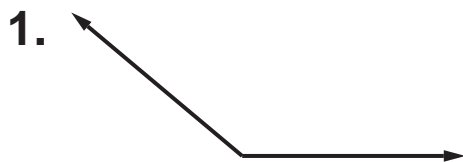

Use a protractor and a straightedge to draw angles having the following measurements.

3. 45°

4. 125°

5. 87°

6. **Standardized Test Practice** Estimate the measure of the angle formed by the hands of a clock at 6:25 a.m.

ANSWERS

1. about 140°

2. about 30°

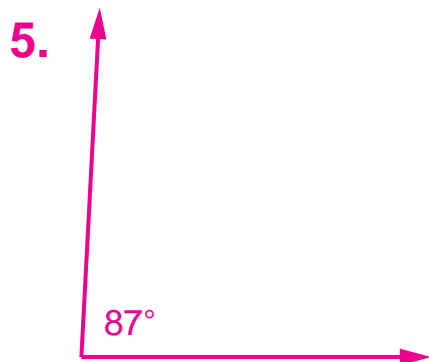
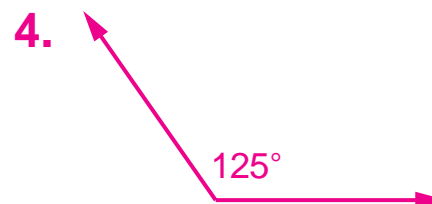
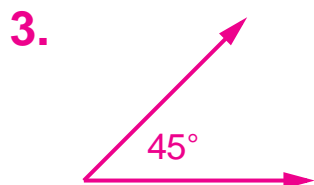

6. about 15°



Draw each line segment having the given measurement. Then use a straightedge and a compass to bisect the line segment.

1. $\frac{3}{4}$ in.

For Exercises 2–4, refer to angle $\angle AVD$.

2. Which ray bisects $\angle BVD$?

3. Name another angle and its bisector.

4. What do you know about the measure of angles $\angle BVC$ and $\angle CVD$? Why?

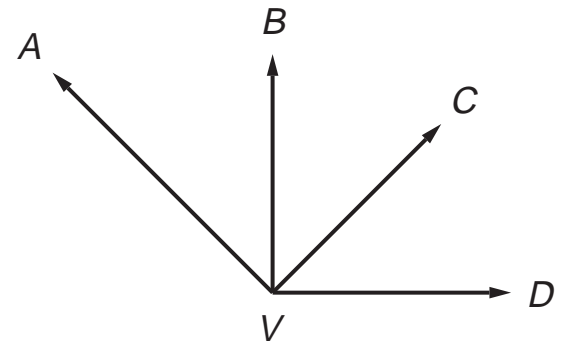

5. **Standardized Test Practice** If a 122° angle is bisected, what is the measure of each remaining angle?

ANSWERS

1.

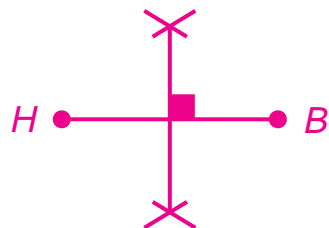

2. \overrightarrow{VC}

3. $\angle AVC$; \overrightarrow{VB}

4. They have the same measure, because \overrightarrow{VC} bisects $\angle BVD$.

5. 61°



Identify each polygon. Then tell if it is a regular polygon.

1.

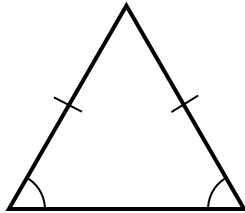

2.

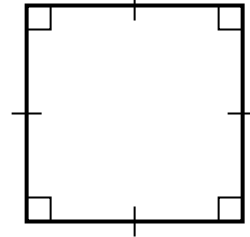

3.

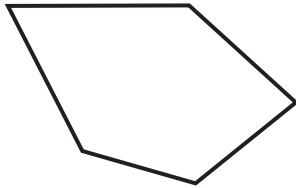

4.

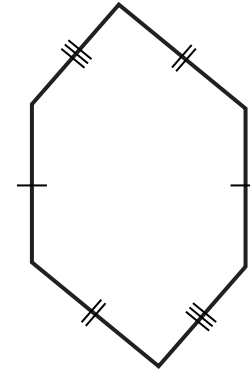

5. Is a football field a regular quadrilateral? Why or why not?

6. **Standardized Test Practice** What is the measure of one of the angles in a regular triangle?

A 180°

B 90°

C 60°

D 30°

ANSWERS

1. triangle; not regular

2. square; regular

3. pentagon; not regular

4. hexagon; not regular

5. No, because it is longer than it is wide so all the sides are not equal.

6. C



Trace each figure. Then draw all lines of symmetry.

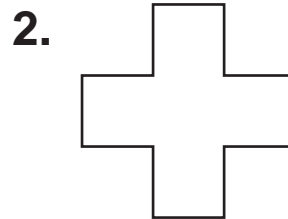

Tell whether each figure has rotational symmetry. Write *yes* or *no*.

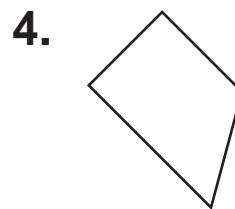
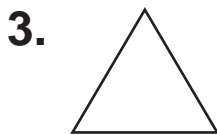

5. Does a stop sign without the word "STOP" have rotational symmetry?

6. **Standardized Test Practice** Which letter has rotational symmetry?

(A) A

(B) T

(C) Z

(D) P

ANSWERS

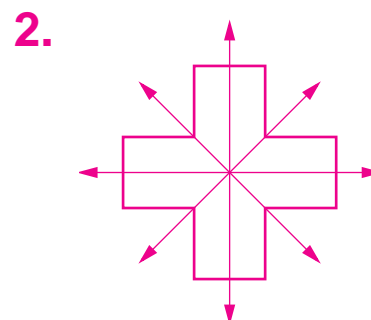

3. *yes*

4. *no*

5. *yes*

6. *C*



Estimate the measure of each angle. Then classify each angle as *acute*, *obtuse*, *right*, or *straight*.

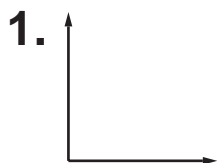

Identify each polygon. Then tell if it is a regular polygon.

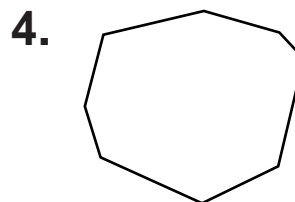
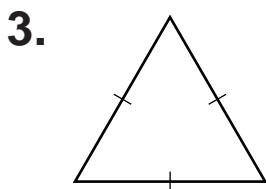

5. How many lines of rotational symmetry does a standard piece of blank paper have? Why?

6. **Standardized Test Practice** If $\angle A$ and $\angle B$ are complementary, and $m\angle A$ is 46° , what is $m\angle B$?

(A) 44°

(B) 46°

(C) 134°

(D) 314°

ANSWERS

1. 90° , right

2. 150° , obtuse

3. triangle, regular

4. octagon, not regular

5. 2; because the paper is in a rectangle, and there are no diagonal lines of symmetry.

6. A



Find the area of each parallelogram. Round to the nearest tenth if necessary.

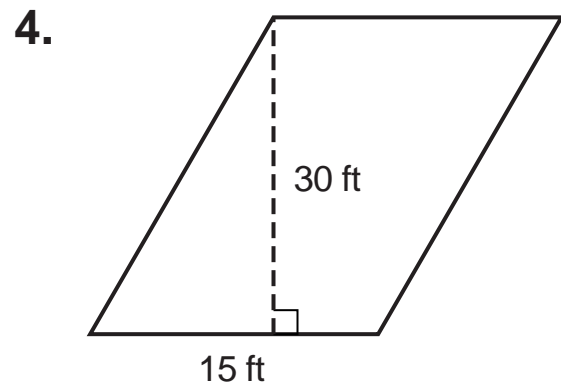
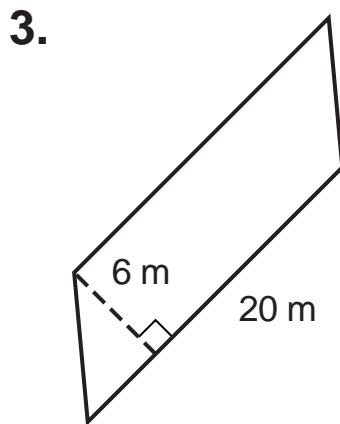
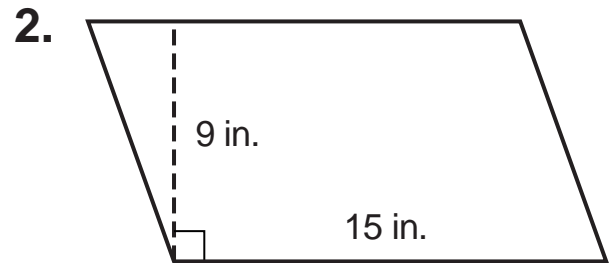
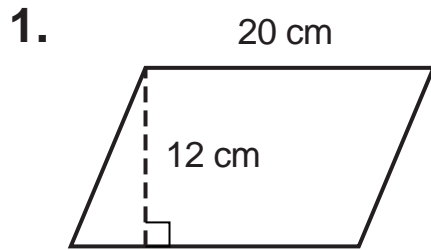

5. Find the area of a parallelogram with base 5.25 yards and height 2.5 yards. Round to the nearest tenth.

6. **Standardized Test Practice** What is the area of a parallelogram that has a height of 10 m and a width of 5.5 m?

- A 5.5 m² B 15.5 m² C 55 m² D 550 m²

ANSWERS

1. 240 cm²

2. 135 in²

3. 120 m²

4. 450 ft²

5. 13.1 yd²

6. C



Find the area of each triangle. Round to the nearest tenth if necessary.

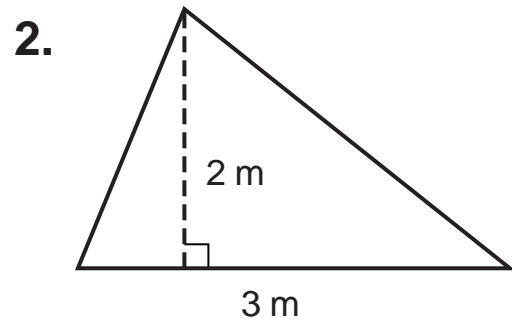
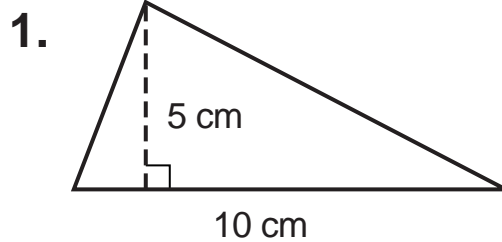

3. A triangular sail is 40 feet tall and 25 feet long. What is the area of the sail?

4. **Standardized Test Practice**

What is the area of the kite in square inches?

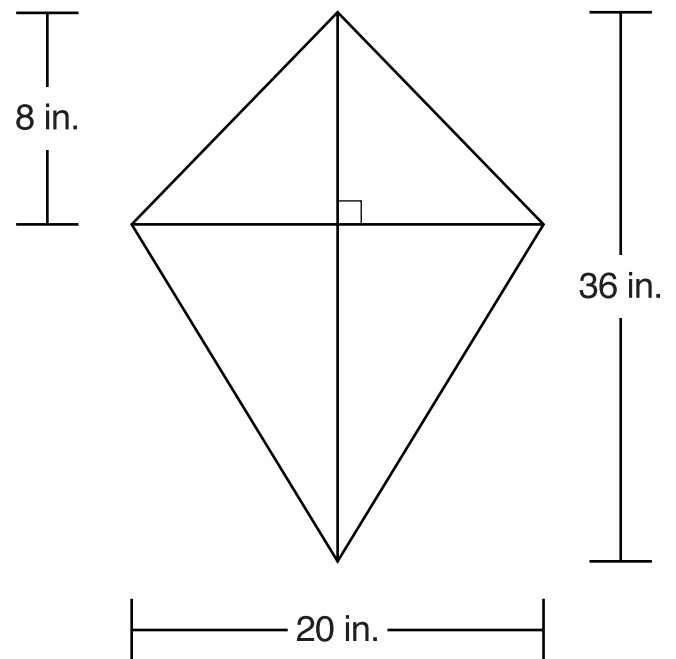

ANSWERS

1. 25 cm^2

3. 500 ft^2

2. 3 m^2

4. 360 in^2



Find the area of each circle to the nearest tenth. Use 3.14 for π .

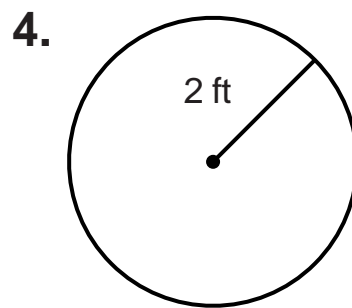
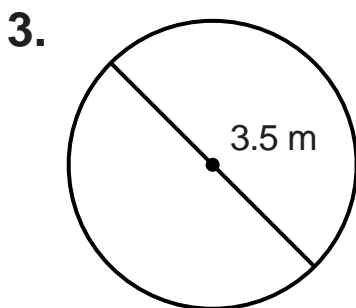
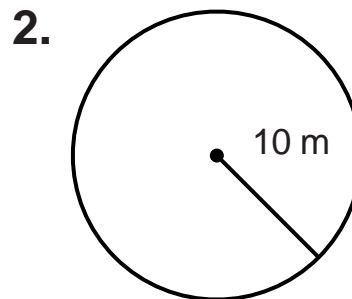
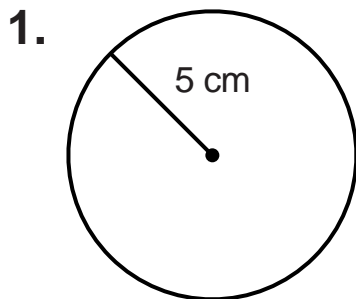

5. What is the area of a circle with a diameter of 6.5 units?

6. **Standardized Test Practice** If a round plate has a radius of 6 inches, what is the area of the plate?

A 18.84 in²

B 28.26 in²

C 37.68 in²

D 113.04 in²

ANSWERS

1. 78.5 cm²

2. 314 m²

3. 9.6 m²

4. 12.6 ft²

5. 33.2 square units

6. D



Identify each figure.

1.

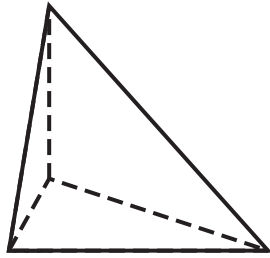

2.

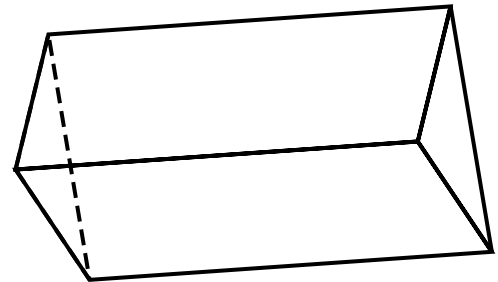

3.

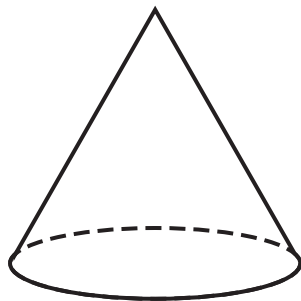

4.

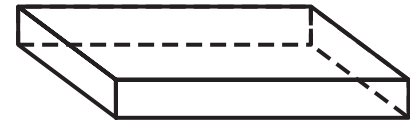

5. What is the name that best describes the shape of a can of soup?

6. **Standardized Test Practice** The lateral sides of a square pyramid are _____.

A squares

B circles

C cubes

D triangles

ANSWERS

1. triangular pyramid

2. triangular prism

3. cone

4. rectangular prism

5. cylinder

6. D



Find the volume of each figure. Round to the nearest tenth if necessary.

1.

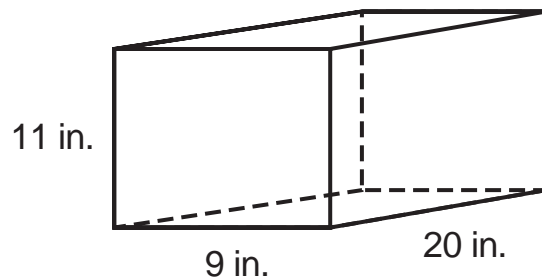

2.

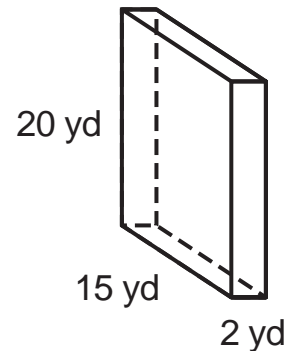

3.

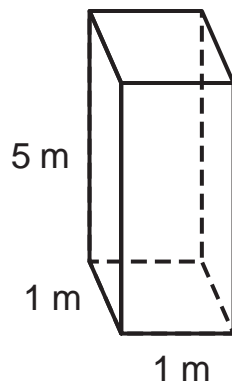

4.

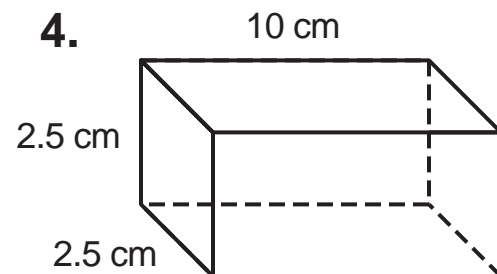

5. What is the volume of a box that measures 2 feet by 3 feet by 1.5 feet?

6. **Standardized Test Practice** What is the volume of a cube with edges measuring 3 units?

A 3 cubic units

B 6 cubic units

C 9 cubic units

D 27 cubic units

ANSWERS

1. 1,980 in³

2. 600 yd³

3. 5 m³

4. 62.5 cm³

5. 9 ft³

6. D