

# Unit 3

## Algebra and Number Sense: Proportions and Percents

### FOCUS

Develop an understanding of and apply proportionality.

### CHAPTER 6

#### Ratios and Proportions

**BIG Idea** Use ratio and proportionality to solve problems, including those with tables and graphs.

### CHAPTER 7

#### Applying Percents

**BIG Idea** Solve percent problems using ratios and proportions.



© iStockphoto.com/Alain/Getty Images





## Problem Solving in Art



### Real-World Unit Project

**It's Golden!** On this adventure, you'll learn about the Golden Ratio in art and nature. Along the way, you'll research how artists use the Golden Ratio to create masterpieces. Also, you'll learn how the Golden Ratio occurs in nature as well. Our adventure will begin soon, so pack your art supplies and math tool kit. This is one golden adventure!

**IN Math Online**

Log on to [glencoe.com](http://glencoe.com) to begin.





# CHAPTER

# 6

# Ratios and Proportions

## Indiana Academic Standards

**7.1.9** Solve problems involving ratios and proportions. **7.2.5** Find the slope of a line from its graph and relate the slope of a line to similar triangles.

## Key Vocabulary

**rate** (p. 287)

**ratio** (p. 282)

**proportional** (p. 310)

## Real-World Link

**Statues** A bronze replica of the Statue of Liberty can be found in Paris, France. The replica has the ratio 1 : 4 with the Statue of Liberty that stands in New York Harbor.

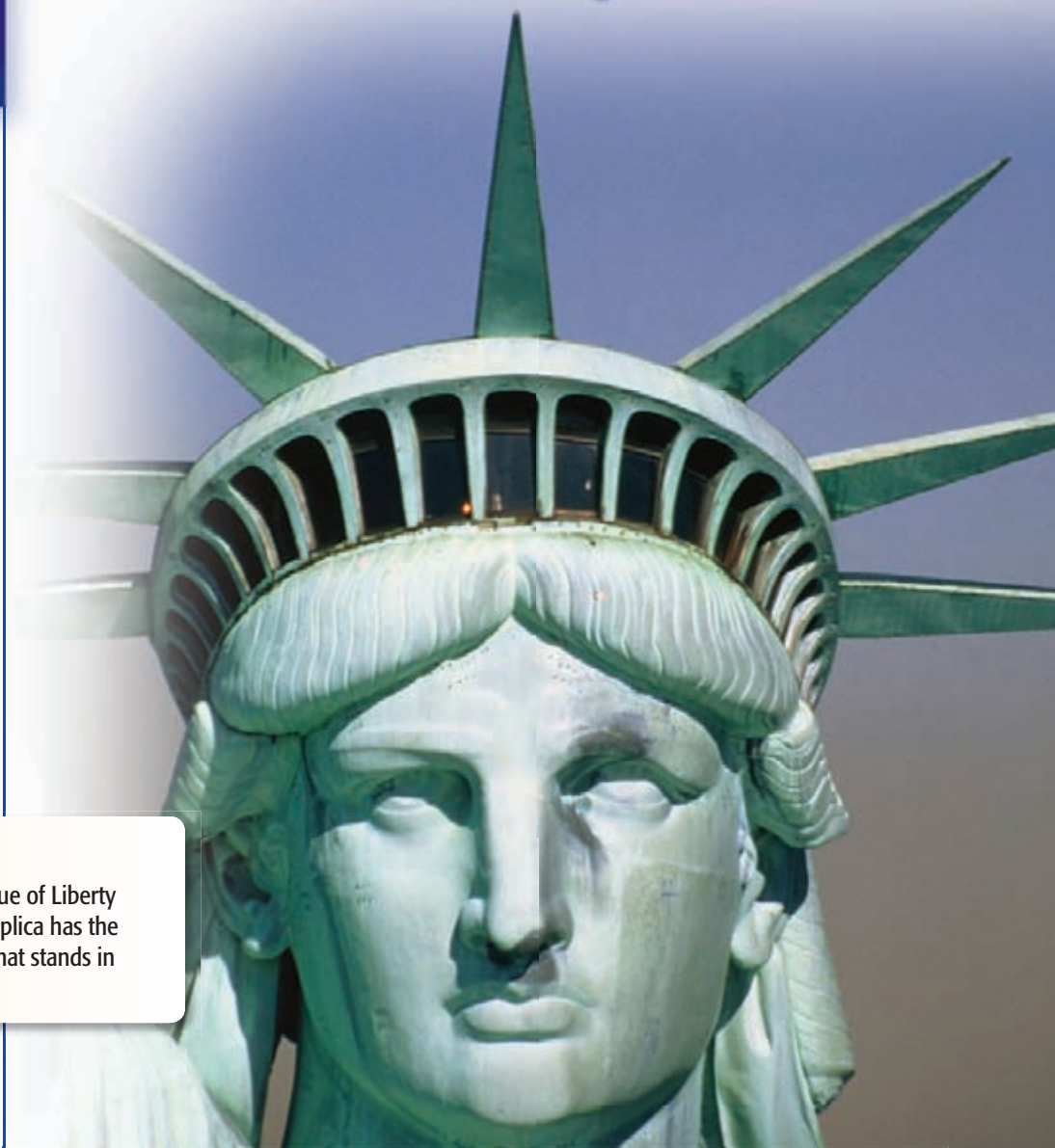

## FOLDABLES<sup>®</sup> Study Organizer

**Ratios and Proportions** Make this Foldable to help you organize your notes. Begin with a sheet of notebook paper.

**1** **Fold** lengthwise to the holes.

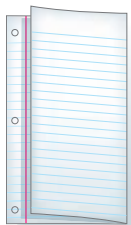

**2** **Cut** along the top line and then make equal cuts to form 7 tabs.



**3** **Label** the major topics as shown.

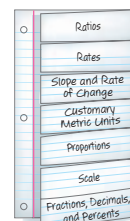

# GET READY for Chapter 6

**Diagnose Readiness** You have two options for checking Prerequisite Skills.

## Option 2

**IN Math Online**

Take the Online Readiness Quiz at [glencoe.com](http://glencoe.com).

## Option 1

Take the Quick Quiz below. Refer to the Quick Review for help.

### QUICK Quiz

Evaluate each expression. Round to the nearest tenth if necessary. (Lesson 1-4)

1.  $100 \times 25 \div 52$     2.  $10 \div 4 \times 31$

3.  $\frac{63 \times 4}{34}$     4.  $\frac{2 \times 100}{68}$

Write each fraction in simplest form.

(Lesson 4-4)

5.  $\frac{9}{45}$     6.  $\frac{16}{24}$     7.  $\frac{38}{46}$

8. **AGES** Mikhail is 14 years old. His father is 49 years old. What fraction, in simplest form, of his father's age is Mikhail?

(Lesson 4-4)

Write each decimal as a fraction in simplest form. (Lesson 4-5)

9. 0.78    10. 0.320    11. 0.06

12. **SAVINGS** Belinda has saved 0.92 of the cost of a new bicycle. What fraction, in simplest form, represents her savings? (Lesson 4-5)

Multiply. (Lesson 1-2)

13.  $4.5 \times 10^2$     14.  $1.78 \times 10^3$

15.  $0.22 \times 10^4$     16.  $0.03 \times 10^5$

### QUICK Review

**Example 1** Evaluate  $15 \times 32 \div 40$ .

$$15 \times 32 \div 40 = 480 \div 40 \quad \text{Multiply 15 by 32.} \\ = 12 \quad \text{Divide.}$$

**Example 2** Write  $\frac{16}{44}$  in simplest form.

$$\frac{16}{44} = \frac{4}{11}$$

*(Arrows indicate dividing numerator and denominator by 4)*

Divide the numerator and denominator by their GCF, 4.

**Example 3** Write 0.62 as a fraction in simplest form.

$$0.62 = \frac{62}{100} \quad \text{0.62 is sixty-two hundredths.} \\ = \frac{31}{50} \quad \text{Divide the numerator and denominator by their GCF, 2.}$$

**Example 4** Find  $3.9 \times 10^3$ .

$$3.9 \times 10^3 = 3,900 \quad \text{Move the decimal point 3} \\ \text{places to the right. Annex} \\ \text{two zeros.} \\ = 3,900$$



**MAIN IDEA**

Write ratios as fractions in simplest form and determine whether two ratios are equivalent.

**IN Academic Standards**

**7.1.9 Solve problems involving ratios and proportions.**

- Express one quantity as a fraction of another, given their ratio, and vice versa.
- Find how many times one quantity is as large as another, given their ratio, and vice versa.
- Express one quantity as a fraction of another given the two quantities.
- Find the whole, or one part, when a whole is divided into parts in a given ration.
- Solve problems involving two pairs of equivalent ratios.

**New Vocabulary**

**ratio**  
**equivalent ratios**

**IN Math Online**

[glencoe.com](http://glencoe.com)

- Extra Examples
- Personal Tutor
- Self-Check Quiz
- Reading in the Content Area

**▶ GET READY for the Lesson**

**SCHOOL** The student-teacher ratio of a school compares the total number of students to the total number of teachers.

Middle School	Students	Teachers
Prairie Lake	396	22
Green Brier	510	30

1. Write the student-teacher ratio of Prairie Lake Middle School as a fraction. Then write this fraction with a denominator of 1.
2. Can you determine which school has the lower student-teacher ratio by examining just the number of teachers at each school? just the number of students at each school? Explain.

**Ratios****Key Concept**

**Words** A **ratio** is a comparison of two quantities by division.

**Examples**

**Numbers**  
3 to 4   3:4    $\frac{3}{4}$

**Algebra**  
 $a$  to  $b$     $a:b$     $\frac{a}{b}$

Ratios can express part to part, part to whole, or whole to part relationships and are often written as fractions in simplest form.

**EXAMPLE Write Ratios in Simplest Form**

- 1 GRILLING** Seasonings are often added to meat prior to grilling. Using the recipe, write a ratio comparing the amount of garlic powder to the amount of dried oregano as a fraction in simplest form.

$$\frac{\text{garlic powder } 4 \text{ tsp}}{\text{dried oregano } 6 \text{ tsp}} = \frac{4 \cancel{\text{tsp}}^2}{6 \cancel{\text{tsp}}_3} \text{ or } \frac{2}{3}$$

The ratio of garlic powder to dried oregano is  $\frac{2}{3}$ , 2:3, or 2 to 3. That is, for every 2 units of garlic powder there are 3 units of dried oregano.

**✓ CHECK Your Progress**

Use the recipe to write each ratio as a fraction in simplest form.

- a. pepper : garlic powder                      b. oregano : pepper





Ratios that express the same relationship between two quantities are called **equivalent ratios**. Equivalent ratios have the same value.

### Study Tip

**Writing Ratios**  
Ratios greater than 1 are expressed as improper fractions and not as mixed numbers.

## EXAMPLE Identify Equivalent Ratios

- 2 Determine whether the ratios 250 miles in 4 hours and 500 miles in 8 hours are equivalent.

### METHOD 1 Compare the ratios written in simplest form.

$$250 \text{ miles} : 4 \text{ hours} = \frac{250 \div 2}{4 \div 2} \text{ or } \frac{125}{2} \quad \text{Divide the numerator and denominator by the GCF, 2}$$

$$500 \text{ miles} : 8 \text{ hours} = \frac{500 \div 4}{8 \div 4} \text{ or } \frac{125}{2} \quad \text{Divide the numerator and denominator by the GCF, 4}$$

The ratios simplify to the same fraction.

### METHOD 2 Look for a common multiplier relating the two ratios.

$$\frac{250}{4} = \frac{500}{8}$$

$\begin{array}{c} \times 2 \\ \curvearrowright \\ \times 2 \end{array}$

The numerator and denominator of the ratios are related by the same multiplier, 2.

The ratios are equivalent.

### CHOOSE Your Method

Determine whether the ratios are equivalent.

- c. 20 nails for every 5 shingles,      d. 2 cups flour to 8 cups sugar,  
12 nails for every 3 shingles      8 cups flour to 14 cups sugar

## Real-World EXAMPLE

- 3 **BASEBALL** Derek Jeter of the New York Yankees had 32 hits out of 93 times at bat. Jorge Posada had 11 hits out of 31 times at bat. Are these ratios equivalent? Justify your answer.

Derek Jeter

$$32 : 93 = \frac{32}{93}$$

Jorge Posada

$$11 : 31 = \frac{11 \times 3}{31 \times 3} \text{ or } \frac{33}{93}$$

Since  $\frac{32}{93} \neq \frac{33}{93}$ , the ratios are not equivalent.

### CHECK Your Progress

- e. **SWIMMING** A community pool requires there to be at least 3 lifeguards for every 20 swimmers. There are 60 swimmers and 9 lifeguards at the pool. Is this the correct number of lifeguards based on the above requirement? Justify your answer.



### Real-World Link . . . .

In 2006, the New York Yankees had a 0.285 batting average as a team.

Source: Major League Baseball





## CHECK Your Understanding

**Example 1**  
(p. 282)

**FIELD TRIPS** Use the information in the table to write each ratio as a fraction in simplest form.

1. adults:students
2. students:buses
3. buses:people
4. adults:people

Field Trip Statistics	
Students	180
Adults	24
Buses	4

**Example 2**  
(p. 283)

**Determine whether the ratios are equivalent. Explain.**

5. 12 out of 20 doctors agree  
6 out of 10 doctors agree
6. 2 DVDs to 7 CDs  
10 DVDs to 15 CDs

**Example 3**  
(p. 283)

7. **SHOPPING** A grocery store has a brand-name cereal on sale at 2 boxes for \$5. You buy 6 boxes and are charged \$20. Based on the price ratio indicated, were you charged the correct amount? Justify your answer.

## Practice and Problem Solving



### HOMEWORK HELP

For Exercises	See Examples
8–17	1
18–21	2
22–23	3

**SOCCKER** Use the Madison Mavericks team statistics to write each ratio as a fraction in simplest form.

8. wins:losses
9. losses:ties
10. losses:games played
11. wins:games played

Madison Mavericks Team Statistics	
Wins	10
Losses	12
Ties	8

**CARNIVALS** Use the following information to write each ratio as a fraction in simplest form.

At its annual carnival, Brighton Middle School had 6 food booths and 15 games booths. A total of 66 adults and 165 children attended. The carnival raised a total of \$1,600. Of this money, \$550 came from ticket sales.

12. children:adults
13. food booths:games booths
14. children:games booths
15. booths:money raised
16. people:children
17. non-ticket sale money:total money

**Determine whether the ratios are equivalent. Explain.**

18. 20 female lions to 8 male lions,  
34 female lions to 10 male lions
19. \$4 for every 16 ounces,  
\$10 for every 40 ounces
20. 27 students to 6 microscopes,  
18 students to 4 microscopes
21. 8 roses to 6 babies breath,  
12 roses to 10 babies breath
22. **BAKING** It is recommended that a ham be baked 1 hour for every 2 pounds of meat. Latrell baked a 9-pound ham for 4.5 hours. Did he follow the above recommendation? Justify your answer.
23. **FISHING** Kamala catches two similar looking fish. The larger fish is 12 inches long and 3 inches wide. The smaller fish is 6 inches long and 1 inch wide. Do these fish have an equivalent length to width ratio? Justify your answer.





**MEASUREMENT** The *aspect ratio* of a television is a ratio comparing the width and height. A wide screen television has an aspect ratio of 16:9. Televisions without the same aspect ratio crop the image to fit the screen. Determine which television sizes have a full 16:9 image. Justify your answers.



24.  $32'' \times 18''$

25.  $71'' \times 42''$

26.  $48'' \times 36''$

**MAMMALS** For Exercises 27 and 28, use the information below.

Mammal	Average Brain Weight (lb)	Average Body Weight (lb)
Adult Human	3	150
Adult Orca Whale	12	5,500



**Real-World Link . . .**

An orca whale, also called a killer whale, is not really a whale, but a dolphin. Its average birth weight is 300 pounds.

27. How much greater is the average weight of an adult orca whale's brain than the average weight of an adult human's brain?
28. Find the brain-to-body weight ratio for each mammal. Are these ratios equivalent? If not, which mammal has the greater brain-to-body weight ratio? Justify your answer and explain its meaning.

29. **MUSIC** The pitch of a musical note is measured by the number of sound waves per second, or *hertz*. If the ratio of the frequencies of two notes can be simplified, the two notes are harmonious. Use the information at the right to find if notes E and G are harmonious. Explain.

**E : 330 Hertz**

**G : 396 Hertz**



30. **FOOD** The ratio of the number of cups of chopped onion to the number of cups of chopped cilantro in a salsa recipe is 4:3. If the recipe calls for  $\frac{2}{3}$  cup chopped onion, how many cups of chopped cilantro are needed?



**ANALYZE TABLES** For Exercises 31–33, use the table below that shows the logging statistics for three areas of forest.

Area	Estimated Number of Trees Left to Grow	Estimated Number of Trees Removed for Timber
A	440	1,200
B	1,625	3,750
C	352	960

31. For which two areas was the growth-to-removal ratio the same? Explain.
32. Which area had the greatest growth-to-removal ratio? Justify your answer.
33. Find the additional number of trees that should be planted and left to grow in area A so that its growth-to-removal ratio is the same as area B's. Justify your answer.

**Academic Standards • ISTEP+**

Extra Practice, pp. 681, 709

## H.O.T. Problems

34. **FIND THE ERROR** Cleveland and Luis are determining whether the ratios  $\frac{6}{4}$  and  $\frac{18}{16}$  are equivalent. Who is correct? Explain.



Cleveland



Luis

$\frac{6}{4} = \frac{18}{16}$  The ratios are equivalent.  
+12 (above and below)

$\frac{6}{4} = \frac{18}{16}$  The ratios are not equivalent.  
×3 (above) and ×4 (below)

35. **CHALLENGE** Find the missing number in the following pattern. Explain your reasoning. (*Hint*: Look at the ratios of successive numbers.)

20, 40, 120, 480, ■

36. **WRITING IN MATH** Refer to the application in Exercises 31–33. What would a growth-to-removal ratio greater than 1 indicate?

### ISTEP+ PRACTICE 7.1.9

37. Which of the following ratios does *not* describe a relationship between the marbles in the jar?

- A 8 white : 5 black
- B 2 white : 5 black
- C 5 black : 13 total
- D 8 white : 13 total



38. A class of 24 students has 15 boys. What ratio compares the number of girls to boys in the class?

- F 3:5
- H 3:8
- G 5:3
- J 8:3

## Spiral Review

39. Find  $1\frac{4}{7} \div 1\frac{5}{6}$ . Write in simplest form. (Lesson 5-7)

**ALGEBRA** Solve each equation. Check your solution. (Lesson 5-6)

40.  $\frac{y}{4} = 7$       41.  $\frac{1}{3}x = \frac{5}{9}$       42.  $4 = \frac{p}{2.7}$       43.  $2\frac{5}{6} = \frac{1}{2}a$

44. **MONEY** Grant and his brother put together their money to buy a present for their mom. If they had a total of \$18 and Grant contributed \$10, how much did his brother contribute? (Lesson 3-2)

### GET READY for the Next Lesson

**PREREQUISITE SKILL** Divide. (p. 676)

45.  $9.8 \div 2$       46.  $\$4.30 \div 5$       47.  $\$12.40 \div 40$       48.  $27.36 \div 3.2$



# 6-2

# Rates

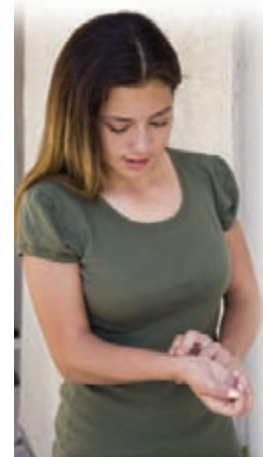

## MAIN IDEA

Determine unit rates.

## IN Academic Standards

### 7.1.9 Solve problems involving ratios and proportions.

- Express one quantity as a fraction of another, given their ratio, and vice versa.
- Find how many times one quantity is as large as another, given their ratio, and vice versa.
- Express one quantity as a fraction of another given the two quantities.
- Find the whole, or one part, when a whole is divided into parts in a given ration.
- Solve problems involving two pairs of equivalent ratios.

Also addresses 7.3.6.

## New Vocabulary

**rate**

**unit rate**

## IN Math Online

[glencoe.com](http://glencoe.com)

- Extra Examples
- Personal Tutor
- Self-Check Quiz

## MINI Lab

Choose a partner and take turns taking each other's pulse for 2 minutes.

- Count the number of beats for each of you.
- Write the ratio *beats to minutes* as a fraction.

A ratio that compares two quantities with different kinds of units is called a **rate**.

$$\frac{160 \text{ beats}}{2 \text{ minutes}}$$

The units *beats* and *minutes* are different.

When a rate is simplified so that it has a denominator of 1 unit, it is called a **unit rate**.

$$\frac{80 \text{ beats}}{1 \text{ minute}}$$

The denominator is 1 unit.

The table below shows some common unit rates.

Rate	Unit Rate	Abbreviation	Name
$\frac{\text{number of miles}}{1 \text{ hour}}$	miles per hour	mi/h or mph	average speed
$\frac{\text{number of miles}}{1 \text{ gallon}}$	miles per gallon	mi/gal or mpg	gas mileage
$\frac{\text{number of dollars}}{1 \text{ pound}}$	price per pound	dollars/lb	unit price
$\frac{\text{number of dollars}}{1 \text{ hour}}$	dollars per hour	dollars/h	hourly wage



## Real-World EXAMPLE

## Find a Unit Rate

**1 WORKING** Desiree earns \$280 in 40 hours. What is her hourly pay rate?

$$\$280 \text{ in } 40 \text{ hours} = \frac{\$280}{40 \text{ h}}$$

Write the rate as a fraction.

$$= \frac{\$280 \div 40}{40 \text{ h} \div 40}$$

Divide the numerator and the denominator by 40.

$$= \frac{\$7}{1 \text{ h}}$$

Simplify.

Desiree's hourly pay rate is \$7.



## CHECK Your Progress

Find each unit rate. Round to the nearest hundredth if necessary.

a. \$300 for 6 hours

b. 220 miles on 8 gallons



## Real-World EXAMPLE

## Find a Unit Rate

- 2 JUICE** Find the unit price if it costs \$2 for eight juice boxes. Round to the nearest cent if necessary.

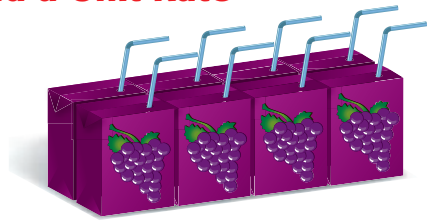

$$\begin{aligned} \$2 \text{ for eight boxes} &= \frac{\$2}{8 \text{ boxes}} \\ &= \frac{\$2 \div 8}{8 \text{ boxes} \div 8} \\ &= \frac{\$0.25}{1 \text{ box}} \end{aligned}$$

Write the rate as a fraction.

Divide the numerator and the denominator by 8.

Simplify.

The unit price is \$0.25 per juice box.



## CHECK Your Progress

- c. **ESTIMATION** Find the unit price if a 4-pack of mixed fruit sells for \$2.12.

Unit rates are useful when you want to make comparisons.



## ISTEP+ EXAMPLE

## 7.1.9 Compare Using Unit Rates

- 3** The prices of 3 different bags of dog food are given in the table. Which size bag has the lowest price per pound?

Dog Food Prices	
Bag Size (pounds)	Price
40	\$49.00
20	\$23.44
8	\$9.88

- A the 40-lb bag  
 B the 20-lb bag  
 C the 8-lb bag  
 D All three bag sizes have the same price per pound.

### Test-Taking Tip

#### Alternative Method

One 40-lb bag is equivalent to two 20-lb bags or five 8-lb bags. The cost for one 40-lb bag is \$49, the cost for two 20-lb bags is about  $2 \times \$23$  or \$46, and the cost for five 8-lb bags is about  $5 \times \$10$  or \$50. So the 20-lb bag has the lowest price per pound.

### Read the Item

To determine the lowest price per pound, find and compare the unit price for each size bag.

### Solve the Item

$$\begin{aligned} 40\text{-pound bag} & \quad \$49.00 \div 40 \text{ pounds} = \$1.225 \text{ per pound} \\ 20\text{-pound bag} & \quad \$23.44 \div 20 \text{ pounds} = \$1.172 \text{ per pound} \\ 8\text{-pound bag} & \quad \$9.88 \div 8 \text{ pounds} = \$1.235 \text{ per pound} \end{aligned}$$

At \$1.172 per pound, the 20-pound bag sells for the lowest price per pound.

The answer is B.





### ✓ CHECK Your Progress

d. Tito wants to buy some peanut butter to donate to the local food pantry. If Tito wants to save as much money as possible, which brand should he buy?

F Nutty, because the quality of the peanut butter is better

G Grandma's, because the price per ounce is about \$0.16

H Bee's, because the price per ounce is about \$0.14

J Save-A-Lot, because he wants to buy 40 ounces

Peanut Butter Sales	
Brand	Sale Price
Nutty	12 ounces for \$2.19
Grandma's	18 ounces for \$2.79
Bee's	28 ounces for \$4.69
Save-A-Lot	40 ounces for \$6.60



#### Real-World Link . . . .

Face paint can be made from 1 teaspoon cornstarch and  $\frac{1}{2}$  teaspoon each of water and cold cream.



### Real-World EXAMPLE Use a Unit Rate

**4** **FACE PAINTING** Lexi painted 3 faces in 12 minutes at the Crafts Fair. At this rate, how many faces can she paint in 40 minutes?

Find the unit rate. Then multiply this unit rate by 40 to find the number of faces she can paint in 40 minutes.

$$3 \text{ faces in 12 minutes} = \frac{3 \text{ faces} \div 12}{12 \text{ min} \div 12} = \frac{0.25 \text{ faces}}{1 \text{ min}} \quad \text{Find the unit rate.}$$

$$\frac{0.25 \text{ faces}}{1 \text{ min}} \cdot 40 \text{ min} = 10 \text{ faces} \quad \text{Divide out the common units.}$$



Lexi can paint 10 faces in 40 minutes.

### ✓ CHECK Your Progress

e. **SCHOOL SUPPLIES** Kimbel bought 4 notebooks for \$6.32. At this same unit price, how much would he pay for 5 notebooks?



### CHECK Your Understanding

**Examples 1, 2**  
(pp. 287–288)

Find each unit rate. Round to the nearest hundredth if necessary.

- 90 miles on 15 gallons
- 1,680 kilobytes in 4 minutes
- 5 pounds for \$2.49
- 152 feet in 16 seconds

**Example 3**  
(pp. 288–289)

**5. MULTIPLE CHOICE** Four stores offer customers bulk CD rates. Which store offers the best buy?

- A CD Express      C Music Place  
B CD Rack          D Music Shop

Bulk CD Offers	
Store	Offer
CD Express	4 CDs for \$60
Music Place	6 CDs for \$75
CD Rack	5 CDs for \$70
Music Shop	3 CDs for \$40

**Example 4**  
(p. 289)

**6. TRAVEL** After 3.5 hours, Pasha had traveled 217 miles. At this same speed, how far will she have traveled after 4 hours?



# Practice and Problem Solving

## HOMESCHOOL HELP

For Exercises	See Examples
7-16	1, 2
17-20	3
21-24	4

Find each unit rate. Round to the nearest hundredth if necessary.

- 360 miles in 6 hours
- 6,840 customers in 45 days
- 152 people for 5 classes
- 815 Calories in 4 servings
- 45.5 meters in 13 seconds
- \$7.40 for 5 pounds
- \$1.12 for 8.2 ounces
- 144 miles in 4.5 gallons
- ESTIMATION** Estimate the unit rate if 12 pairs of socks sell for \$5.79.
- ESTIMATION** Estimate the unit rate if a 26-mile marathon was completed in 5 hours.

- SPORTS** The results of a swim meet are shown. Who swam the fastest? Explain your reasoning.

Name	Event	Time (s)
Tawni	50-m Freestyle	40.8
Pepita	100-m Butterfly	60.2
Susana	200-m Medley	112.4

- MONEY** A grocery store sells three different packages of bottled water. Which package costs the least per bottle? Explain your reasoning.



6-pack for \$3.79



9-pack for \$4.50



12-pack for \$6.89

**NUTRITION** For Exercises 19 and 20, use the table at the right.

- Which soft drink has about twice the amount of sodium per ounce than the other two? Explain.
- Which soft drink has the least amount of sugar per ounce? Explain.

Soft Drink Nutritional Information			
Soft Drink	Serving Size (oz)	Sodium (mg)	Sugar (g)
A	12	40	22
B	8	24	15
C	7	42	30

- WORD PROCESSING** Ben can type 153 words in 3 minutes. At this rate, how many words can he type in 10 minutes?
- FABRIC** Marcus buys 3 yards of fabric for \$7.47. Later he realizes that he needs 2 more yards. How much will he pay for the extra fabric?
- ESTIMATION** A player scores 87 points in 6 games. At this rate, about how many points would she score in the next 4 games?



### Real-World Link . . . . .

North Carolina has approximately 8.9 million people living in 48,718 square miles.

Source: U.S. Census Bureau

- JOBS** Dalila earns \$94.20, for working 15 hours as a holiday helper wrapping gifts. If she works 18 hours the next week, how much money will she earn?
- POPULATION** Use the information at the left. What is the *population density* or number of people per square mile in North Carolina?





**ESTIMATION** Estimate the unit price for each item. Justify your answers.

26.



\$2.49

27.



\$1.89

28.



\$1.13

29. **RECIPES** A recipe that makes 10 mini-loaves of banana bread calls for  $1\frac{1}{4}$  cups flour. How much flour is needed to make 2 dozen mini-loaves using this recipe?

•• **SPORTS** For Exercises 30 and 31, use the information at the left.

30. The wheelchair division for the Boston Marathon is 26.2 miles long. What was the average speed of the record winner of the wheelchair division? Round to the nearest hundredth.

31. At this rate, about how long would it take this competitor to complete a 30 mile race?

32. **SPORTS** Mia participated in a race that involved 2 different events. She biked at an average speed of 10 miles per hour for  $1\frac{1}{2}$  hours then ran at an average speed of 7 miles per hour for  $\frac{3}{4}$  hour. What was her average speed for the entire race?



**Real-World Link**

The record for the Boston Marathon's wheelchair division is 1 hour, 18 minutes, and 27 seconds.

Source: Boston Athletic Association



**ANIMALS** For Exercises 33–37, use the graph that shows the average number of heartbeats for an active adult brown bear and a hibernating brown bear.

33. What does the point (2, 120) represent on the graph?

34. What does the point (1.5, 18) represent on the graph?

35. What does the ratio of the  $y$ -coordinate to the  $x$ -coordinate for each pair of points on the graph represent?

36. Use the graph to find the bear's average heart rate when it is active and when it is hibernating.

37. When is the bear's heart rate greater, when it is active or when it is hibernating? How can you tell this from the graph?

38. **TIRES** At Tire Depot, a pair of new tires sells for \$216. The manager's special advertises the same tires selling at a rate of \$380 for 4 tires. How much do you save per tire if you purchase the manager's special?

39. **FIND THE DATA** Refer to the Data File on pages 16–19. Choose some data and write a real-world problem in which you would compare unit rates or ratios.

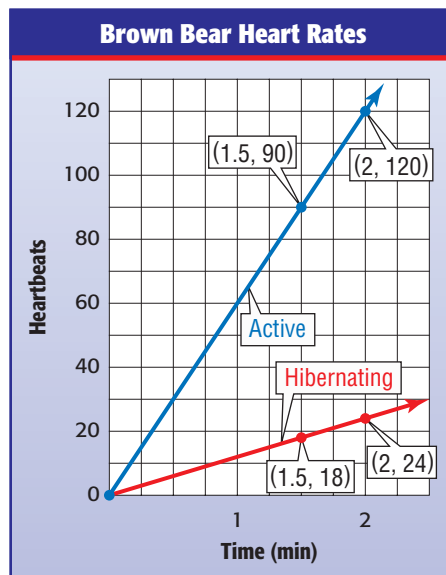

Academic Standards • ISTEP+

Extra Practice, pp. 682, 709

**H.O.T. Problems**

**CHALLENGE** Determine whether each statement is *sometimes*, *always*, or *never* true. Give an example or a counterexample.

40. A ratio is a rate. 41. A rate is a ratio.
42. **OPEN ENDED** Create a rate and then convert it to a unit rate.
43. **NUMBER SENSE** In which situation will the rate  $\frac{x \text{ feet}}{y \text{ minutes}}$  increase? Give an example to explain your reasoning.
- a.  $x$  increases,  $y$  is unchanged b.  $x$  is unchanged,  $y$  increases
44. **WRITING IN MATH** Describe, using an example, how a *rate* is a measure of one quantity per unit of another quantity.

**ISTEP+ PRACTICE** 7.1.9

45. Mrs. Ross needs to buy dish soap. There are four different size containers at a store.

Dish Soap Prices	
Brand	Price
Lots of Suds	\$0.98 for 8 ounces
Bright Wash	\$1.29 for 12 ounces
Spotless Soap	\$3.14 for 30 ounces
Lemon Bright	\$3.45 for 32 ounces

Mrs. Ross wants to buy the one that costs the least per ounce. Which brand should she buy?

- A Lots of Suds C Spotless Soap  
 B Bright Wash D Lemon Bright

46. The table shows the total distance traveled by a car driving at a constant rate of speed.

Time (h)	Distance (mi)
2	130
3.5	227.5
4	260
7	455

Based on this information, how far will the car have traveled after 10 hours?

- F 520 miles H 650 miles  
 G 585 miles J 715 miles

**Spiral Review**

**FLOWERS** For Exercises 47–50, use the information in the table to write each ratio as a fraction in simplest form. (Lesson 6-1)

47. lilies : roses 48. snapdragons : lilies  
 49. roses : flowers 50. flowers : snapdragons

Flower Arrangement	
Lilies	4
Roses	18
Snapdragons	6

51. **SANDWICHES** Lawanda is making subs. She puts  $1\frac{1}{2}$  slices of cheese on each sub. If she has 12 slices of cheese, how many subs can she make? (Lesson 5-6)

**GET READY for the Next Lesson**

**PREREQUISITE SKILL** Write each fraction in simplest form. (Lesson 4-3)

52.  $\frac{8}{12}$  53.  $\frac{9}{18}$  54.  $\frac{25}{35}$  55.  $\frac{10}{40}$



# 6-3

# Rate of Change and Slope

## MAIN IDEA

Identify rate of change and slope using tables and graphs.

## IN Academic Standards

**7.2.5** Find the slope of a line from its graph and relate the slope of a line to similar triangles. **7.2.6** Draw the graph of a line given its slope and one point on the line or two points on the line. Also addresses 7.1.9.

## New Vocabulary

rate of change  
slope

## IN Math Online

[glencoe.com](http://glencoe.com)

- Extra Examples
- Personal Tutor
- Self-Check Quiz

## ▶ GET READY for the Lesson

**HEIGHTS** The table shows Stephanie's height at ages 9 and 12.

Age (yr)	9	12
Height (in.)	53	59

1. What is the change in Stephanie's height from ages 9 to 12?
2. Over what number of years did this change take place?
3. Write a rate that compares the change in Stephanie's height to the change in age. Express your answer as a unit rate and explain its meaning.

A **rate of change** is a rate that describes how one quantity changes in relation to another. A rate of change is usually expressed as a unit rate.

## EXAMPLE Find Rate of Change from a Table

**1 FUNDRAISING** The table shows the amount of money a Booster Club made washing cars for a fundraiser. Use the information to find the rate of change in dollars per car.

Cars Washed	
Number	Money (\$)
5	40
10	80
15	120
20	160

+5 (change in cars) and +40 (change in money) are shown for each row transition.

Find the unit rate to determine the rate of change.

$$\frac{\text{change in money}}{\text{change in cars}} = \frac{40 \text{ dollars}}{5 \text{ cars}} \quad \text{The money earned increases by } \$40 \text{ for every } 5 \text{ cars.}$$

$$= \frac{8 \text{ dollar}}{1 \text{ car}} \quad \text{Write as a unit rate.}$$

So, the number of dollars earned increases by \$8 for every car washed.

## ✓ CHECK Your Progress

a. **PLANES** The table shows the number of miles a plane traveled while in flight. Use the information to find the approximate rate of change in miles per minute.

Time (min)	30	60	90	120
Distance (mi)	290	580	870	1,160



### Reading Math

**Ordered Pairs** The ordered pair (2, 120) represents traveling 120 miles in 2 hours.

## EXAMPLE Find Rate of Change from a Graph

**2 DRIVING** The graph represents the distance traveled while driving on a highway. Use the graph to find the rate of change in miles per hour.

To find the rate of change, pick any two points on the line, such as (1, 60) and (2, 120).

$$\begin{aligned} \frac{\text{change in miles}}{\text{change in hours}} &= \frac{(120 - 60) \text{ miles}}{(2 - 1) \text{ hours}} \\ &= \frac{60 \text{ miles}}{1 \text{ hour}} \end{aligned}$$

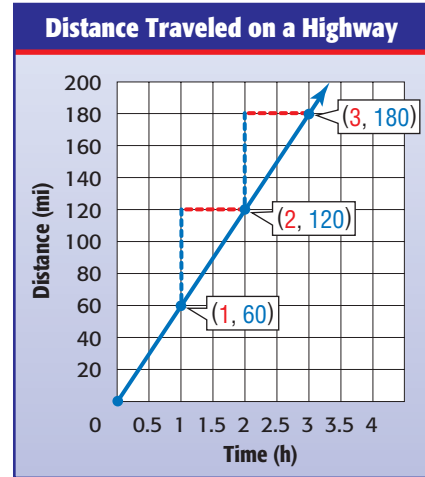

The distance increases by 60 miles in 1 hour. So, the rate of traveling on a highway is 60 miles per hour.

### ✓ CHECK Your Progress

b. **DRIVING** Use the graph to find the rate of change in miles per hour while driving in the city.

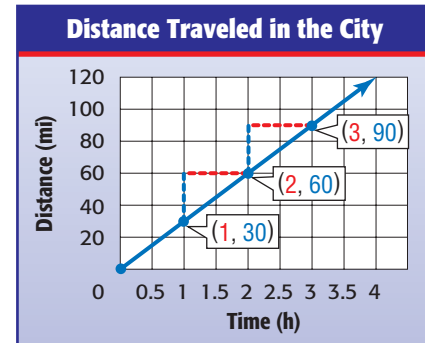

Notice that the graph in Example 2 about driving on a highway represents a rate of change of 60 mph. The graph in Check Your Progress about driving in the city is not as steep. It represents a rate of change of 30 mph.

The constant rate of change in  $y$  with respect to the constant change  $x$  is also called the slope of a line. Slope is a number that tells how steep the line is. The slope is the same for any two points on a straight line.

## Slope

### Key Concept

**Slope** is the rate of change between any two points on a line.

$$\begin{aligned} \text{slope} &= \frac{\text{change in } y}{\text{change in } x} \quad \leftarrow \begin{array}{l} \text{vertical change} \\ \text{horizontal change} \end{array} \\ &= \frac{2}{1} \text{ or } 2 \end{aligned}$$

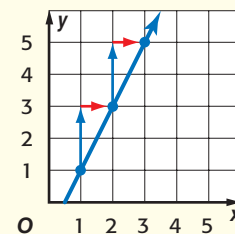





## Real-World EXAMPLE

## Find Slope



3

**PHYSICAL SCIENCE** The table below shows the relationship between the number of seconds  $y$  it takes to hear the thunder after a lightning strike and the distance  $x$  you are from the lightning.

Distance ( $x$ )	0	1	2	3	4	5
Seconds ( $y$ )	0	5	10	15	20	25

Graph the data. Then find the slope of the line. Explain what the slope represents.

$$\begin{aligned} \text{slope} &= \frac{\text{change in } y}{\text{change in } x} && \text{Definition of slope} \\ &= \frac{25 - 10}{5 - 2} && \text{Use } (2, 10) \text{ and } (5, 25). \\ &= \frac{15}{3} && \begin{array}{l} \leftarrow \text{seconds} \\ \leftarrow \text{miles} \end{array} \\ &= \frac{5}{1} && \text{Simplify.} \end{aligned}$$

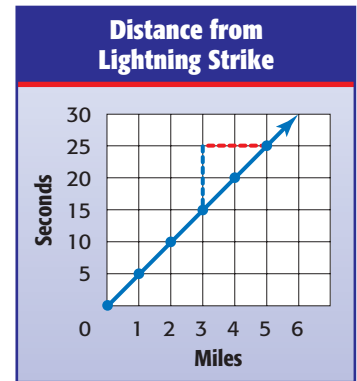

### Real-World Link . . .

Lightning strikes somewhere on the surface of Earth about 100 times every second.

Source: National Geographic



So, for every 5 seconds between a lightning flash and the sound of the thunder, there is 1 mile between you and the lightning strike.



### CHECK Your Progress

c. **WATER** Graph the data. Then find the slope of the line. Explain what the slope represents.

Water Level Loss	
Week	Water Loss (cm)
1	1.5
2	3
3	4.5
4	6



### CHECK Your Understanding

**Example 1**  
(p. 293)

1. Use the information in the table to find the rate of change in degrees per hour.

Temperature (°F)	54	57	60	63
Time	6 A.M.	8 A.M.	10 A.M.	12 P.M.

**Example 2**  
(p. 294)

2. **DISTANCE** The graph shows Benito's distance from the starting line. Use the graph to find the rate of change.

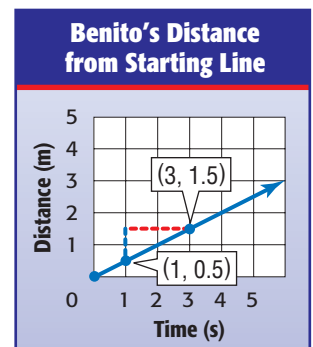



**Example 3**  
(p. 295)

3. **SNACKS** The table below shows the number of small packs of fruit snacks  $y$  per box  $x$ . Graph the data. Then find the slope of the line. Explain what the slope represents.

<b>Boxes (<math>x</math>)</b>	3	5	7	9
<b>Packs (<math>y</math>)</b>	24	40	56	72

## Practice and Problem Solving

### HOMEWORK HELP

For Exercises	See Examples
4–6	1
7, 8	2
9, 10	3

For Exercises 4 and 5, find the rate of change for each table.

4.

Time (s)	Distance (m)
0	6
1	12
2	18
3	24

5.

Time (h)	Wage (\$)
0	0
1	9
2	18
3	27

6. The number of minutes included in different cell phone plans and the costs are shown in the table. What is the approximate rate of change in cost per minute?

Cost (\$)	38	50	62	74	86
Minutes	1,000	1,500	2,000	2,500	3,000

For Exercises 7 and 8, find the rate of change for each graph.

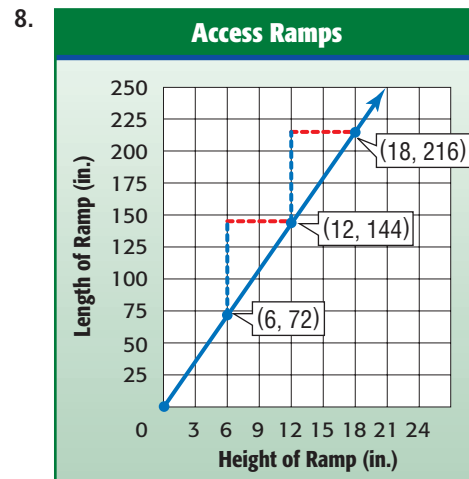
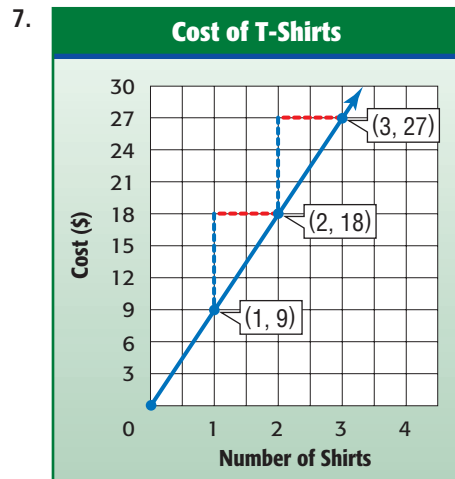

9. **CYCLING** The table shows the distance  $y$  Cheryl traveled in  $x$  minutes while competing in the cycling portion of a triathlon. Graph the data. Then find the slope of the line. Explain what the slope represents.

Time (min)	45	90	135	180
Distance (km)	5	10	15	20

**Academic Standards • ISTEP+**  
Extra Practice, pp. 682, 709





10. **MAPS** The table shows the key for a map. Graph the data. Then find the slope of the line.

<b>Distance on Map (in.)</b>	2	4	6	8
<b>Actual Distance (mi)</b>	40	80	120	160

11. **WATER** At 1:00, the water level in a pool is 13 inches. At 2:30, the water level is 28 inches. What is the rate of change?
12. **MONEY** Dwayne opens a savings account with \$75. He makes the same deposit every month and makes no withdrawals. After 3 months, he has \$150. After 6 months, he has \$300. After 9 months, he has \$450 dollars. What is the rate of change?

**H.O.T. Problems**

13. **OPEN ENDED** Make a table where the rate of change is 6 inches for every foot.
14. **WRITING IN MATH** Write a problem to represent a rate of change of \$15 per item.



**ISTEP+ PRACTICE** 7.2.5, 7.2.6

15. Use the information in the table to find the rate of change.

Number of Apples	Number of Seeds
3	30
7	70
11	110

- A  $\frac{10}{1}$                       C  $\frac{40}{4}$   
 B  $\frac{1}{10}$                       D  $\frac{4}{40}$

16. **SHORT RESPONSE** Find the slope of the line below that shows the distance Jairo traveled while jogging.

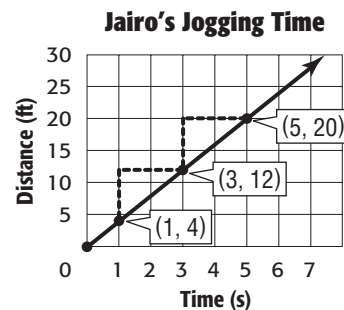

**Spiral Review**

17. **GROCERIES** Three pounds of pears cost \$3.57. At this rate, how much would 10 pounds cost? (Lesson 6-2)

Write each ratio as a fraction in simplest form. (Lesson 6-1)

18. 9 feet in 21 minutes      19. 36 calls in 2 hours      20. 14 SUVs out of 56 vehicles

**GET READY for the Next Lesson**

**PREREQUISITE SKILL** Solve. (Page 674)

21.  $2.5 \times 20$                       22.  $3.5 \times 4$                       23.  $104 \div 16$                       24.  $4,200 \div 2,000$

# 6-4

## Measurement: Changing Customary Units

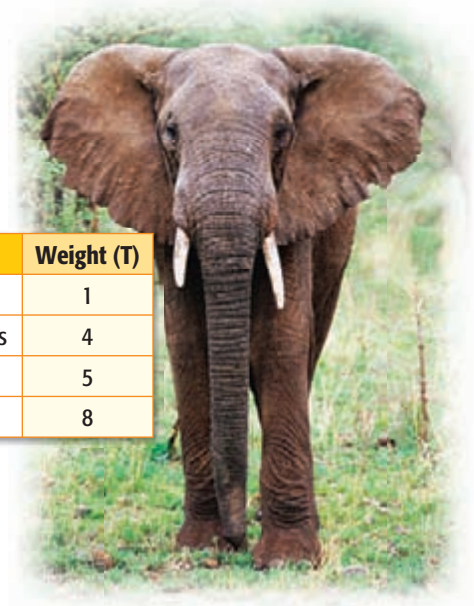

### MAIN IDEA

Change units in the customary system.

### IN Academic Standards

#### Preparation for 8.3.4

Solve simple problems involving rates and other derived measurements, including problems involving speed, uniform speed, average speed and density, by applying the concept of proportionality to measurement in different contexts. Express measurements in a given unit in terms of other units of the same type. Also addresses 7.3.6, P.6.4.

### New Vocabulary

**unit ratio**

### IN Math Online

[glencoe.com](http://glencoe.com)

- Extra Examples
- Personal Tutor
- Self-Check Quiz

### ▶ GET READY for the Lesson

**ANIMALS** The table shows the approximate weights in tons of several large land animals. One ton is equivalent to 2,000 pounds.

Animal	Weight (T)
Grizzly Bear	1
White Rhinoceros	4
Hippopotamus	5
African Elephant	8

You can use a *ratio table*, which have columns filled with ratios that have the same value, to convert each weight from tons to pounds.

1. Copy and complete the ratio table. The first two ratios are done for you.

	$\times 4$			
<b>Tons</b>	1	4	5	8
<b>Pounds</b>	2,000	8,000	■	■
		$\times 4$		

To produce equivalent ratios, multiply the quantities in each row by the same number.

2. Then graph the ordered pairs (tons, pounds) from the table. Label the horizontal axis *Weight in Tons* and the vertical axis *Weight in Pounds*. Connect the points. What do you notice about the graph of these data?

The relationships among the most commonly used customary units of length, weight, and capacity are shown in the table below.

Customary Units			Key Concept
Type of Measure	Larger Unit	→	Smaller Unit
<b>Length</b>	1 foot (ft)	=	12 inches (in.)
	1 yard (yd)	=	3 feet
	1 mile (mi)	=	5,280 feet
<b>Weight</b>	1 pound (lb)	=	16 ounces (oz)
	1 ton (T)	=	2,000 pounds
<b>Capacity</b>	1 cup (c)	=	8 fluid ounces (fl oz)
	1 pint (pt)	=	2 cups
	1 quart (qt)	=	2 pints
	1 gallon (gal)	=	4 quarts



Each of the relationships above can be written as a unit ratio. Like a unit rate, a **unit ratio** is one in which the denominator is 1 unit.

$$\frac{3 \text{ ft}}{1 \text{ yd}} \quad \frac{2,000 \text{ lb}}{1 \text{ T}} \quad \frac{4 \text{ qt}}{1 \text{ gal}}$$

Notice that the numerator and denominator of each fraction above are equivalent, so the value of each ratio is 1. You can multiply by a unit ratio of this type to *convert* or change from larger units to smaller units.

### Study Tip

**Multiplying by 1**  
Although the number and units changed in Example 1, because the measure is multiplied by 1, the value of the converted measure is the same as the original.

## EXAMPLES

### Convert Larger Units to Smaller Units

#### 1 Convert 20 feet into inches.

Since 1 foot = 12 inches, the unit ratio is  $\frac{12 \text{ in.}}{1 \text{ ft}}$ .

$$20 \text{ ft} = 20 \text{ ft} \cdot \frac{12 \text{ in.}}{1 \text{ ft}}$$

Multiply by  $\frac{12 \text{ in.}}{1 \text{ ft}}$ .

$$= 20 \cancel{\text{ft}} \cdot \frac{12 \text{ in.}}{1 \cancel{\text{ft}}}$$

Divide out common units, leaving the desired unit, inches.

$$= 20 \cdot 12 \text{ in. or } 240 \text{ in.} \quad \text{Multiply.}$$

So, 20 feet = 240 inches.

#### 2 **GARDENING** Clarence mixes $\frac{1}{4}$ cup of fertilizer with soil before planting each bulb. How many ounces of fertilizer does he use per bulb?

$$\frac{1}{4} \text{ c} = \frac{1}{4} \cancel{\text{c}} \cdot \frac{8 \text{ fl oz}}{1 \cancel{\text{c}}}$$

Since 1 cup = 8 fluid ounces, multiply by  $\frac{8 \text{ fl oz}}{1 \text{ c}}$ . Then, divide out common units.

$$= \frac{1}{4} \cdot 8 \text{ fl oz or } 2 \text{ fl oz} \quad \text{Multiply.}$$

So, 2 fluid ounces of fertilizer are used per bulb.

## CHECK Your Progress

Complete.

a. 36 yd =  ft

b.  $\frac{3}{4}$  T =  lb

c.  $1\frac{1}{2}$  qt =  pt

### Review Vocabulary

**reciprocal** The product of a number and its reciprocal is 1; *Example:* The reciprocal of  $\frac{3}{5}$  is  $\frac{5}{3}$ . (Lesson 5-7)

To convert from smaller units to larger units, multiply by the reciprocal of the appropriate unit ratio.

## EXAMPLES

### Convert Smaller Units to Larger Units

#### 3 Convert 15 quarts into gallons.

Since 1 gallon = 4 quarts, the unit ratio is  $\frac{4 \text{ qt}}{1 \text{ gal}}$ , and its reciprocal is  $\frac{1 \text{ gal}}{4 \text{ qt}}$ .

$$15 \text{ qt} = 15 \text{ qt} \cdot \frac{1 \text{ gal}}{4 \text{ qt}}$$

Multiply by  $\frac{1 \text{ gal}}{4 \text{ qt}}$ .

$$= 15 \cancel{\text{qt}} \cdot \frac{1 \text{ gal}}{4 \cancel{\text{qt}}}$$

Divide out common units, leaving the desired unit, gallons.

$$= 15 \cdot \frac{1}{4} \text{ gal or } 3.75 \text{ gal}$$

Multiplying 15 by  $\frac{1}{4}$  is the same as dividing 15 by 4.





- 4 COSTUMES** Umeka needs  $4\frac{1}{2}$  feet of fabric to make a costume for a play. How many yards of fabric does she need?

$$4\frac{1}{2} \text{ ft} = 4\frac{1}{2} \text{ ft} \cdot \frac{1 \text{ yd}}{3 \text{ ft}}$$

Since 1 yard = 3 feet, multiply by  $\frac{1 \text{ yd}}{3 \text{ ft}}$ . Then, divide out common units.

$$= \frac{\overset{3}{\cancel{9}}}{2} \cdot \frac{1}{\underset{1}{\cancel{3}}} \text{ yd}$$

Write  $4\frac{1}{2}$  as an improper fraction. Then divide out common factors.

$$= \frac{3}{2} \text{ yd or } 1\frac{1}{2} \text{ yd} \quad \text{Multiply.}$$

So Umeka needs  $1\frac{1}{2}$  yards of fabric.

### CHECK Your Progress

Complete.

d. 2,640 ft =  mi

e. 5 pt =  qt

f. 100 oz =  lb

g. 76c =  gal

h. 3 c =  pt

i. 18 in. =  ft

- j. **FOOD** A 3-pound pork loin can be cut into 10 smaller pork chops of equal weight. How many ounces does each pork chop weigh?

You can also convert from one rate to another by multiplying by a unit rate or its reciprocal.

### Real-World EXAMPLE **Convert Rates**

- 5 HELICOPTERS** A helicopter flies at a rate of 158 miles per hour. How many miles per second is this?

Since 1 hour = 3,600 seconds, multiply by  $\frac{1 \text{ h}}{3,600 \text{ s}}$ .

$$\frac{158 \text{ mi}}{\text{h}} = \frac{158 \text{ mi}}{1 \text{ h}} \times \frac{1 \text{ h}}{3,600 \text{ s}} \quad \text{Multiply by } \frac{1 \text{ h}}{3,600 \text{ s}}$$

$$= \frac{158 \text{ mi}}{1 \cancel{\text{h}}} \times \frac{1 \cancel{\text{h}}}{3,600 \text{ s}} \quad \text{Divide out common units.}$$

$$\approx \frac{0.04 \text{ mi}}{1 \text{ s}} \quad \text{Simplify.}$$

So, a helicopter flies approximately 0.04 mile per second.

### CHECK Your Progress

- k. **FISH** A swordfish can swim at a rate of 60 miles per hour. How many feet per hour is this?

- l. **WALKING** Ava walks at a speed of 7 feet per second. How many feet per hour is this?



#### Real-World Link . . . . .

A swordfish reaches a maximum size of 14 feet and almost 1,200 pounds.

Source: Sport Fishing Central



## CHECK Your Understanding

**Examples 1, 2**  
(p. 299)

Complete.

1. 3 lb = ■ oz

2.  $5\frac{1}{3}$  yd = ■ ft

3. 6.5 c = ■ fl oz

4. **FISH** Grouper are members of the sea bass family. A large grouper can weigh  $\frac{1}{3}$  ton. About how much does a large grouper weigh to the nearest pound?

**Examples 3, 4**  
(pp. 299–300)

Complete.

5. 12 qt = ■ gal

6. 28 in. = ■ ft

7. 15 pt = ■ qt

8. **VEHICLES** The world's narrowest electric vehicle is about 35 inches wide and is designed to move down narrow aisles in warehouses. About how wide is this vehicle to the nearest foot?

**Example 5**  
(p. 300)

9. **RUNNING** The fastest a human has ever run is about 27 miles per hour. How many miles per minute is this?

## Practice and Problem Solving

### **HOMEWORK HELP**

For Exercises	See Examples
10–21	1–4
22–23	2
24–25	4
26–27	5

Complete.

10. 18 ft = ■ yd

11. 72 oz = ■ lb

12. 2 lb = ■ oz

13. 4 gal = ■ qt

14.  $4\frac{1}{2}$  pt = ■ c

15. 3 c = ■ fl oz

16. 2 mi = ■ ft

17.  $1\frac{1}{4}$  mi = ■ ft

18. 5,000 lb = ■ T

19. 13 c = ■ pt

20.  $2\frac{3}{4}$  qt = ■ pt

21.  $3\frac{3}{8}$  T = ■ lb



22. **PUMPKINS** One of the largest pumpkins ever grown weighed about  $\frac{1}{2}$  ton. How many pounds did the pumpkin weigh?

23. **SKIING** Speed skiing takes place on a course that is  $\frac{2}{3}$  mile long. How many feet long is the course?

24. **BOATING** A 40-foot power boat is for sale by owner. About how long is this boat to the nearest yard?

25. **BLOOD** A total of 35 pints of blood were collected at a local blood drive. How many quarts of blood is this?

26. **GO-KARTS** A go-kart's top speed is 607,200 feet per hour. How many miles per hour is this?

27. **BIRDS** A peregrine falcon can fly at over 200 miles per hour. How many feet per hour is this?



28. **PUNCH** Will a 2-quart pitcher hold the entire recipe of citrus punch given at the right? Explain your reasoning.

**Recipe: Citrus Punch Drink**

- 2 cups orange juice
- 2 cups grapefruit juice
- $\frac{1}{4}$  cup apricot nectar
- $\frac{1}{3}$  cup pineapple juice
- 4 cups ginger ale



29. **WEATHER** On Monday, it snowed a total of 15 inches. On Tuesday and Wednesday, it snowed an additional  $4\frac{1}{2}$  inches and  $6\frac{3}{4}$  inches, respectively. A weather forecaster says that over the last three days, it snowed about  $2\frac{1}{2}$  feet. Is this a valid claim? Justify your answer.

**MEASUREMENT Accuracy** describes how close a measurement is to its actual value. Choose the correct term to determine the degree of accuracy needed in each situation.

- 30. The length of a cruise ship would be described in (inches, feet).
- 31. Fabric for a jacket would be measured to the nearest (inch, eighth of an inch).
- 32. A bag of apples would be weighed to the nearest (tenth of a pound, tenth of an ounce).
- 33. **ESTIMATION** Cristos is a member of the swim team and trains by swimming an average of 3,000 yards a day. About how many miles would he swim by training at this rate for 5 days, to the nearest half-mile?

**MEASUREMENT For Exercises**

34–37, use the graph at the right.

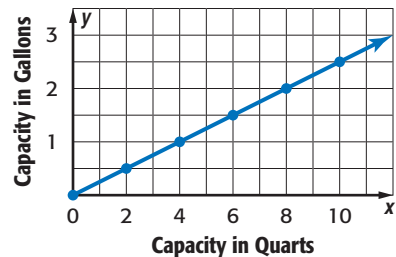

- 34. What does an ordered pair from this graph represent?
- 35. Find the slope of the line.
- 36. Use the graph to find the capacity in quarts of a 2.5-gallon container. Explain your reasoning.
- 37. Use the graph to predict the capacity in gallons of a 12-quart container. Explain your reasoning.

**Academic Standards • ISTEP+**  
Extra Practice, pp. 682, 709



**H.O.T. Problems**

**REASONING** Replace each  $\bullet$  with  $<$ ,  $>$ , or  $=$  to make a true sentence. Justify your answers.

- 38. 16 in.  $\bullet$   $1\frac{1}{2}$  ft
- 39.  $8\frac{3}{4}$  gal  $\bullet$  32 qt
- 40. 2.7 T  $\bullet$  86,400 oz

41. **CHALLENGE** To whiten fabrics, a certain Web site recommends that you soak them in a mixture of  $\frac{3}{4}$  cup vinegar, 2 quarts water, and some salt. Does a mixture that contains 1.5 ounces vinegar and 16 ounces water have the same vinegar-to-water ratio as the recommended mixture? Explain.

42. **WRITING IN MATH** Use multiplication by unit ratios of equivalent measures to convert 5 square feet to square inches. Justify your answer.



## ISTEP+ PRACTICE

### Preparation for 8.3.4

43. Which situation is represented by the graph?

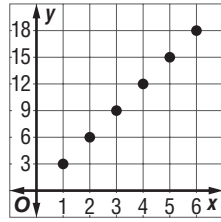

- A conversion of inches to yards
- B conversion of feet to inches
- C conversion of miles to feet
- D conversion of yards to feet

44. How many cups of milk are shown below?



- F  $\frac{3}{4}$  c
  - G  $1\frac{1}{4}$  c
  - H  $2\frac{1}{2}$  c
  - J 10 c
45. How many ounces are in  $7\frac{3}{4}$  pounds?
- A 124 oz
  - B 122 oz
  - C 120 oz
  - D 112 oz

## Spiral Review

46. Use the information in the table to find the rate of change in dollars per hour. (Lesson 6-3)

Wage (\$)	0	9	18	27
Time (h)	0	1	2	3

47. **GROCERIES** Find the unit price if Anju spent \$2 for six oranges. Round to the nearest cent if necessary. (Lesson 6-2)
48. **MEASUREMENT** By doubling just the length of the rectangular ice skating rink in Will's backyard from 16 to 32 feet, he increased its area from 128 square feet to 256 square feet. Find the width of both rinks. (Lesson 3-6)

**ALGEBRA** For Exercises 50–52, use the pay stub at the right. (Lesson 3-3)

49. Write and solve an equation to find the regular hourly wage.
50. Write and solve an equation to find the overtime hourly wage.
51. Write and solve an equation to find how many times greater Grace's overtime hourly wage is than her regular hourly wage.

Martin, Grace		Employee #: 4211
Description:	Hours:	Earnings (\$):
Regular hours:	40	300.00
Overtime hours:	2	22.50

## ▶ GET READY for the Next Lesson

**PREREQUISITE SKILL** Multiply. (p. 674)

52.  $14.5 \times 8.2$

53.  $7.03 \times 4.6$

54.  $9.29 \times 15.3$

55.  $1.84 \times 16.7$

# 6-5

## Measurement: Changing Metric Units

### MAIN IDEA

Change metric units of length, capacity, and mass.

### IN Academic Standards

#### Preparation for

**8.3.4** Solve simple problems involving rates and other derived measurements, including problems involving speed, uniform speed, average speed and density, by applying the concept of proportionality to measurement in different contexts. Express measurements in a given unit in terms of other units of the same type. *Also addresses 7.3.6, P.6.4.*

### New Vocabulary

metric system  
meter  
liter  
gram  
kilogram

### IN Math Online

[glencoe.com](http://glencoe.com)

- Extra Examples
- Personal Tutor
- Self-Check Quiz

### MINI Lab

The lengths of two objects are shown below.

Object	Length (millimeters)	Length (centimeters)
paper clip	45	4.5
CD case	144	14.4

1. Select three other objects. Find and record the width of all five objects to the nearest millimeter and tenth of a centimeter.
2. Compare the measurements of the objects, and write a rule that describes how to convert from millimeters to centimeters.
3. Measure the length of your classroom in meters. Make a conjecture about how to convert this measure to centimeters. Explain.



The **metric system** is a decimal system of measures. The prefixes commonly used in this system are kilo-, centi-, and milli-

Prefix	Meaning In Words	Meaning In Numbers
kilo-	thousands	1,000
centi-	hundredths	0.01
milli-	thousandths	0.001

In the metric system, the base unit of *length* is the **meter** (m). Using the prefixes, the names of other units of length are formed. Notice that the prefixes tell you how the units relate to the meter.

Unit	Symbol	Relationship to Meter	
kilometer	km	1 km = 1,000 m	1 m = 0.001 km
meter	m	1 m = 1 m	
centimeter	cm	1 cm = 0.01 m	1 m = 100 cm
millimeter	mm	1 mm = 0.001 m	1 m = 1,000 mm

The **liter** (L) is the base unit of *capacity*, the amount of dry or liquid material an object can hold. The **gram** (g) measures *mass*, the amount of matter in an object. The prefixes can also be applied to these units. Whereas the meter and liter are the base units of length and capacity, the base unit of mass is the **kilogram** (kg).



To change a metric measure of length, mass, or capacity from one unit to another, you can use the relationship between the two units and multiplication by a power of 10.

### Study Tip

**Metric Conversions**  
When converting from a larger unit to a smaller unit, the power of ten being multiplied will be greater than 1.  
When converting from a smaller unit to a larger unit, the power of ten will be less than 1.

## EXAMPLES Convert Units in the Metric System

### 1 Convert 4.5 liters to milliliters.

You need to convert liters to milliliters. Use the relationship

$$1 \text{ L} = 1,000 \text{ mL}$$

Write the relationship.

$$4.5 \times 1 \text{ L} = 4.5 \times 1,000 \text{ mL}$$

Multiply each side by 4.5 since you have 4.5 L.

$$4.5 \text{ L} = 4,500 \text{ mL}$$

To multiply 4.5 by 1,000, move the decimal point 3 places to the right.

### 2 Convert 500 millimeters to meters.

You need to convert millimeters to meters. Use the relationship

$$1 \text{ mm} = 0.001 \text{ m}$$

Write the relationship.

$$500 \times 1 \text{ mm} = 500 \times 0.001 \text{ m}$$

Multiply each side by 500 since you have 500 mm.

$$500 \text{ mm} = 0.5 \text{ m}$$

To multiply 500 by 0.001, move the decimal point 3 places to the left.

### CHECK Your Progress

Complete.

a.  $25.4 \text{ g} = \square \text{ kg}$

b.  $158 \text{ mm} = \square \text{ m}$



### Real-World Link . . . . .

The maximum weight of a grizzly bear is 521.64 kilograms.

Source: North American Bear Center

## Real-World EXAMPLE

### 3 BEARS The California Grizzly Bear was designated the official state animal in 1953. Use the information at the left to find the maximum weight of a grizzly bear in grams.

You are converting kilograms to grams. Since the maximum weight of a grizzly bear is 521.64 kilograms, use the relationship  $1 \text{ kg} = 1,000 \text{ g}$ .

$$1 \text{ kg} = 1,000 \text{ g}$$

Write the relationship.

$$521.64 \times 1 \text{ kg} = 521.64 \times 1,000 \text{ g}$$

Multiply each side by 521.64 since you have 521.64 kg.

$$521.64 \text{ kg} = 521,640 \text{ g}$$

To multiply 521.64 by 1,000, move the decimal point 3 places to the right.

So, the maximum weight of a grizzly bear is 521,640 grams.

### CHECK Your Progress

c. **FOOD** A bottle contains 1.75 liters of juice. How many milliliters is this?



To convert measures between customary units and metric units, use the relationships below.

Customary and Metric Relationships			Key Concept
Type of Measure	Customary	→	Metric
<b>Length</b>	1 inch (in.)	≈	2.54 centimeters (cm)
	1 foot (ft)	≈	0.30 meter (m)
	1 yard (yd)	≈	0.91 meter (m)
	1 mile (mi)	≈	1.61 kilometers (km)
<b>Weight/Mass</b>	1 pound (lb)	≈	453.6 grams (g)
	1 pound (lb)	≈	0.4536 kilogram (kg)
	1 ton (T)	≈	907.2 kilograms (kg)
<b>Capacity</b>	1 cup (c)	≈	236.59 milliliters (mL)
	1 pint (pt)	≈	473.18 milliliters (mL)
	1 quart (qt)	≈	946.35 milliliters (mL)
	1 gallon (gal)	≈	3.79 liters (L)

### EXAMPLES Convert Between Measurement Systems

#### Study Tip

**Alternative Method**  
When converting 17.22 inches to centimeters, you can use the relationship  $1 \text{ in.} \approx 2.54 \text{ cm}$  or the unit ratio  $\frac{2.54 \text{ cm}}{1 \text{ in.}}$ .

- 4** Convert 17.22 inches to centimeters. Round to the nearest hundredth if necessary.

Use the relationship  $1 \text{ inch} \approx 2.54 \text{ centimeters}$ .

$$1 \text{ inch} \approx 2.54 \text{ cm} \quad \text{Write the relationship.}$$

$$17.22 \times 1 \text{ in.} \approx 17.22 \times 2.54 \text{ cm} \quad \text{Multiply each side by 17.22 since you have 17.22 in.}$$

$$17.22 \text{ in.} \approx 43.7388 \text{ cm} \quad \text{Simplify.}$$

So, 17.22 inches is approximately 43.74 centimeters.

- 5** Convert 828.5 milliliters to cups. Round to the nearest hundredth if necessary.

Since  $1 \text{ cup} \approx 236.59 \text{ milliliters}$ , multiply by  $\frac{1 \text{ c}}{236.59 \text{ mL}}$ .

$$\begin{aligned} 828.5 \text{ mL} &\approx 828.5 \text{ mL} \cdot \frac{1 \text{ c}}{236.59 \text{ mL}} && \text{Multiply by } \frac{1 \text{ c}}{236.59 \text{ mL}}. \\ &\approx \frac{828.5 \text{ c}}{236.59} \text{ or } 3.5 \text{ c} && \text{Simplify.} \end{aligned}$$

So, 828.5 milliliters is approximately 3.5 cups.

#### CHECK Your Progress

Complete. Round to the nearest hundredth if necessary.

- d.  $7.44 \text{ c} \approx \square \text{ mL}$       e.  $22.09 \text{ lb} \approx \square \text{ kg}$       f.  $35.85 \text{ L} \approx \square \text{ gal}$



## Real-World EXAMPLE

## Convert with Rates

- 6 LIGHT** The speed of light is about 186,000 miles per second. Find the approximate speed of light in kilometers per second.

Since 1 mile  $\approx$  1.61 kilometers, multiply by  $\frac{1.61 \text{ km}}{1 \text{ mi}}$ .

$$\begin{aligned} \frac{186,000 \text{ mi}}{\text{s}} &\approx \frac{186,000 \cancel{\text{ mi}}}{1 \text{ s}} \times \frac{1.61 \text{ km}}{1 \cancel{\text{ mi}}} && \text{Multiply by } \frac{1.61 \text{ km}}{1 \text{ mi}} \\ &\approx \frac{299,460 \text{ km}}{1 \text{ s}} && \text{Simplify.} \end{aligned}$$

So, the speed of light is approximately 299,460 kilometers per second.



### Real-World Link . . . .

Before the seventeenth century, people thought light was transmitted instantly. Now, we know that light is too fast for the delay to be noticeable.

Source: University of California, Riverside



### CHECK Your Progress

- g. **RUNNING** Chuck runs at a speed of 3 meters per second. About how many feet per second does Chuck run?



## CHECK Your Understanding

Examples 1, 2, 4, 5  
(pp. 305–306)

Complete. Round to the nearest hundredth if necessary.

- 3.7 m =  cm
- 550 m =  km
- 1,460 mg =  g
- 2.34 kL =  L
- 9.36 yd  $\approx$   m
- 11.07 pt  $\approx$   mL
- 58.14 kg  $\approx$   lb
- 38.44 cm  $\approx$   in.

Examples 3, 6  
(pp. 305, 307)

9. **SPORTS** About how many feet does a team of athletes run in a 1,600-meter relay race?



## Practice and Problem Solving

### HOMEWORK HELP

For Exercises	See Examples
10–23	1, 2, 4, 5
24–27	3, 6

Complete. Round to the nearest hundredth if necessary.

- 720 cm =  m
- 983 mm =  m
- 3.2 m =  cm
- 0.03 g =  mg
- 997 g =  kg
- 82.1 g =  kg
- 9.1 L =  mL
- 130.5 kL =  L
- 3.75 c  $\approx$   mL
- 41.8 in.  $\approx$   cm
- 156.25 lb  $\approx$   kg
- 9.5 gal  $\approx$   L
- 680.4 g  $\approx$   lb
- 4.725 m  $\approx$   ft

24. **WATERFALLS** At 979 meters tall, Angel Falls in Venezuela is the highest waterfall in the world. How many kilometers tall is the waterfall?
25. **FOOD** An 18-ounce jar contains 510 grams of grape jelly. How many kilograms of grape jelly does the jar contain?



26. **CYCLING** Ramon rides his bike at a rate of 8 kilometers per hour. About how many miles per hour can Ramon ride his bike?
27. **BIRDS** A gull can fly at a speed of 22 miles per hour. About how many meters per hour can a gull fly?



**Complete. Round to the nearest hundredth if necessary.**

28.  $8.18 \text{ qt} \approx \square \text{ L}$     29.  $15.09 \text{ km} \approx \square \text{ yd}$   
 30.  $72.26 \text{ cm} \approx \square \text{ ft}$     31.  $0.445 \text{ T} \approx \square \text{ g}$

**Precision is the ability of a measurement to be consistently reproduced. Choose the correct term to determine the degree of precision needed in each situation.**

32. length of a line segment (meters, centimeters)  
 33. mass of a bowl of cereal (kilograms, grams)

34. **ANALYZE TABLES** The table shows the lengths of bridges in the United States. Which bridges are about 1 kilometer in length? Justify your answer.

Bridge	Length (m)
Mackinac, MI	1,158
George Washington, NY	1,067
Tacoma Narrows II, WA	853
Oakland Bay, CA	704
Pennybacker, TX	345
Sunshine Skyway, FL	8,712
Golden Gate, CA	2,780

35. **CARPENTRY** Jacinta needs a 2.5-meter pole for a birdfeeder that she is building. How many centimeters will she need to cut off a 3-meter pole in order to use it for the birdfeeder?

36. **BAKING** A bakery uses 900 grams of peaches per cobbler. How many cobblers can be made using 10.5 pounds of peaches?



**Real-World Link . . . . .**

The Mackinac Bridge opened on November 1, 1957. It is the longest two-tower suspension bridge between bases in the Western Hemisphere.

Source: *Encyclopaedia Britannica*

Academic Standards • ISTEP+

Extra Practice, pp. 683, 709



**H.O.T. Problems**

37. **FIND THE ERROR** Jake and Gerardo are converting 3.25 kilograms to grams. Who is correct? Explain your reasoning.



Jake

$3.25 \text{ kg} = 3,250 \text{ g}$



Gerardo

$3.25 \text{ kg} = 0.00325 \text{ g}$

**CHALLENGE** For Exercises 38–40, use the following information.

The metric prefix *giga* refers to something one billion times larger than the base unit.

38. How many meters are in one gigameter?  
 39. About how many miles are in one gigameter? Round to the nearest hundredth.  
 40. The distance from Earth to the Sun is approximately 93 million miles. About how many gigameters is this? Round to the nearest hundredth.





41. **WRITING IN MATH** Explain why it makes sense to multiply by a power of 10 that is greater than 1 when changing from a larger unit to a smaller unit.

**ISTEP+ PRACTICE** Preparation for 8.3.4

42. The table shows the mass of four wireless telephones. Find the approximate total mass of the telephones in kilograms.

Telephone Owner	Mass (g)
Elena	100.4
Kevin	70.8
Marissa	95.6
Corey	120.4

- A 0.39 kilogram  
 B 3.9 kilograms  
 C 39.0 kilograms  
 D 390.0 kilograms

43. Which relationship between the given units of measure is correct?

- F One gram is  $\frac{1}{100}$  of a centigram.  
 G One meter is  $\frac{1}{100}$  of a centimeter.  
 H One gram is  $\frac{1}{1,000}$  of a kilogram.  
 J One milliliter is  $\frac{1}{100}$  of a liter.

**Spiral Review**

44. **MEASUREMENT** A certain car weighs 3,200 pounds. What is the weight of the car in tons? (Lesson 6-4)

45. **MEASUREMENT** The table shows the number of inches per foot. Graph the data. Then find the slope of the line. Explain what slope represents. (Lesson 6-3)

Feet ( $x$ )	1	2	3	4
Inches ( $y$ )	12	24	36	48

Add or subtract. Write in simplest form. (Lesson 5-3)

46.  $3\frac{4}{7} + 1\frac{1}{7}$       47.  $8\frac{3}{5} - 2\frac{2}{5}$       48.  $9\frac{1}{6} + 4\frac{3}{8}$       49.  $11\frac{7}{10} - 5\frac{3}{4}$

50. **BASKETBALL** Jared made thirty-seven percent of his free-throw attempts during basketball practice. Write this percent as a decimal. (Lesson 4-7)

**GET READY for the Next Lesson**

**PREREQUISITE SKILL** Solve each equation. (Lesson 3-3)

51.  $5 \cdot 4 = x \cdot 2$       52.  $9 \cdot 24 = 27 \cdot x$       53.  $x \cdot 15 = 12 \cdot 4$       54.  $8\frac{1}{2} \cdot x = 11 \cdot 17$

# 6-6

# Algebra: Solving Proportions

## MAIN IDEA

Solve proportions.

## IN Academic Standards

**7.1.9** Solve problems involving ratios and proportions.

- Express one quantity as a fraction of another, given their ratio, and vice versa.
- Find how many times one quantity is as large as another, given their ratio, and vice versa.
- Express one quantity as a fraction of another given the two quantities.
- Find the whole, or one part, when a whole is divided into parts in a given ration.
- Solve problems involving two pairs of equivalent ratios.

Also addresses 7.2.1, 7.2.2, 7.2.7.

## New Vocabulary

proportional  
proportion  
cross product

## IN Math Online

[glencoe.com](http://glencoe.com)

- Extra Examples
- Personal Tutor
- Self-Check Quiz

## GET READY for the Lesson

**NUTRITION** The amount of calcium in different servings of milk is shown.

- Write the rate  $\frac{\text{calcium}}{\text{number of servings}}$  for each amount of milk.
- Find the number of milligrams per cup for each serving size.  
What do you notice?

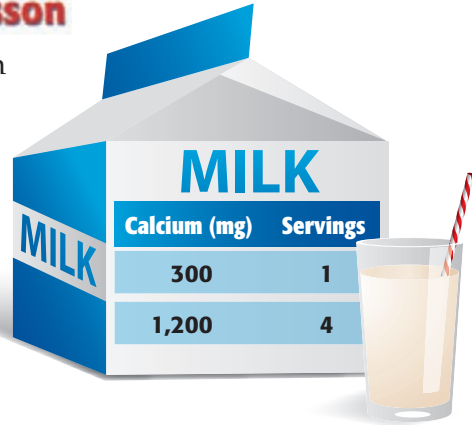

Two quantities are **proportional** if they have a constant rate or ratio. In the example above, notice that the number of servings and amount of calcium change or *vary* in the same way.

$$\frac{300 \text{ mg}}{1 \text{ serving}} = \frac{1,200 \text{ mg}}{4 \text{ servings}}$$

$\times 4$  (above the right side)  
 $\times 4$  (below the left side)

The unit rates for these different-sized servings are the same, a constant 300 milligrams per serving. So, the amount of calcium is proportional to the serving size.

## Proportion

### Key Concept

**Words** A **proportion** is an equation stating that two ratios or rates are equivalent.

**Symbols**

**Numbers**

$$\frac{1}{2} = \frac{3}{6}, \frac{8 \text{ ft}}{10 \text{ s}} = \frac{4 \text{ ft}}{5 \text{ s}}$$

**Algebra**

$$\frac{a}{b} = \frac{c}{d}, \text{ where } b, d \neq 0$$

Consider the following proportion.

$$\frac{a}{b} = \frac{c}{d}$$

$$\frac{a}{b} \cdot \frac{1}{1} \cdot bd = \frac{c}{d} \cdot \frac{1}{1} \cdot bd \quad \text{Multiply each side by } bd.$$

$$ad = bc \quad \text{Simplify.}$$

The products  $ad$  and  $bc$  are called the **cross products** of this proportion. The cross products of any proportion are equal. You can compare unit rates or cross products to identify proportional relationships.



## Reading Math

### Nonproportional

When ratios do not form a proportion, they are called nonproportional.

## EXAMPLE Identify Proportional Relationships

- 1 RECREATION** A carousel makes 4 complete turns after 64 seconds and 5 complete turns after 76 seconds. Based on this information, is the number of turns made by this carousel proportional to the time in seconds? Explain.

### METHOD 1 Compare unit rates.

$$\frac{\text{seconds}}{\text{complete turns}} \rightarrow \frac{64 \text{ s}}{4 \text{ turns}} = \frac{16 \text{ s}}{1 \text{ turn}} \quad \frac{76 \text{ s}}{5 \text{ turns}} = \frac{15.2 \text{ s}}{1 \text{ turn}}$$

Since the unit rates are not equal, the number of turns is not proportional to the time in seconds.

### METHOD 2 Compare ratios by comparing cross products.

$$\begin{array}{l} \text{seconds} \rightarrow \frac{64}{4} \stackrel{?}{=} \frac{76}{5} \leftarrow \text{seconds} \\ \text{complete turns} \rightarrow \frac{64}{4} \stackrel{?}{=} \frac{76}{5} \leftarrow \text{complete turns} \end{array}$$

$$64 \cdot 5 \stackrel{?}{=} 4 \cdot 76 \quad \text{Find the cross products.}$$

$$320 \neq 304 \quad \text{Multiply.}$$

Since the cross products are not equal, the number of turns is not proportional to the time in seconds.

## CHOOSE Your Method

Determine if the quantities in each pair of ratios are proportional. Explain.

- 60 voted out of 100 registered and 84 voted out of 140 registered
- \$12 for 16 yards of fabric and \$9 for 24 yards fabric

You can also use cross products to find a missing value in a proportion. This is known as *solving the proportion*.

## Study Tip

**Mental Math**  
Some proportions can be solved using mental math.

$$\frac{2.5}{10} = \frac{x}{30}$$

$$\frac{2.5}{10} = \frac{7.5}{30}$$

$\times 3$

## EXAMPLES Solve a Proportion

- 2** Solve  $\frac{21}{5} = \frac{c}{7}$ .

$$\frac{21}{5} = \frac{c}{7} \quad \text{Write the proportion.}$$

$$21 \cdot 7 = 5 \cdot c \quad \text{Find the cross products.}$$

$$147 = 5c \quad \text{Multiply.}$$

$$\frac{147}{5} = \frac{5c}{5} \quad \text{Divide each side by 5.}$$

$$29.4 = c \quad \text{Simplify.}$$

**Check for Reasonableness** Since  $\frac{21}{5} \approx \frac{20}{5}$  or  $\frac{4}{1}$  and  $\frac{29.4}{7} \approx \frac{28}{7}$  or  $\frac{4}{1}$ , the answer is reasonable. ✓





**3** Solve  $\frac{2.6}{13} = \frac{8}{n}$ .

$$\frac{2.6}{13} = \frac{8}{n} \quad \text{Write the proportion.}$$

$$2.6 \cdot n = 13 \cdot 8 \quad \text{Find the cross products.}$$

$$2.6n = 104 \quad \text{Multiply.}$$

$$\frac{2.6n}{2.6} = \frac{104}{2.6} \quad \text{Divide each side by 2.6.}$$

$$n = 40 \quad \text{Simplify.}$$

**CHECK Your Progress**

c.  $\frac{16}{k} = \frac{2}{3}$

d.  $\frac{2}{6} = \frac{5}{h}$

e.  $\frac{10}{k} = \frac{2.5}{4}$



**Real-World EXAMPLE**

**4 MEDICINE** For every 18 people who have a sore throat, there are 2 people who actually have strep throat. If 72 patients have sore throats, how many of these would you expect to have strep throat?

**METHOD 1 Write and solve a proportion.**

Let  $s$  represent strep throat.

$$\frac{2 \text{ strep throats}}{18 \text{ sore throats}} = \frac{s}{72 \text{ sore throats}} \quad \text{Write a proportion.}$$

$$2 \cdot 72 = 18 \cdot s \quad \text{Find the cross products.}$$

$$144 = 18s \quad \text{Multiply.}$$

$$8 = s \quad \text{Divide each side by 18.}$$

**METHOD 2 Find and use a unit rate or ratio.**

$$\frac{2 \text{ strep throats} \div 2}{18 \text{ sore throats} \div 2} = \frac{1}{9} \quad \text{The ratio of strep throats to sore throats is } 1 : 9.$$

**Words** For every 9 sore throats, there is 1 strep throat.

**Variable** Let  $s$  represent the number of strep throats.

**Equation** 
$$s = \frac{1}{9} \cdot 72$$

$$s = \frac{1}{9} \cdot 72 \text{ or } 8 \quad \text{Multiply.}$$

So, you would expect 8 people to have strep throat.

**CHOOSE Your Method**

f. **RUNNING** Salvador can run 120 meters in 24 seconds. At this rate, how many seconds will it take him to run a 300-meter race?

**Real-World Career . . .**

**How Does a Physician's Assistant Use Math?**

A physician's assistant uses math when calculating safe dosages of medications.

**IN Math Online**

For more information visit, [glencoe.com](http://glencoe.com).



## CHECK Your Understanding

**Example 1** Determine if the quantities in each pair of ratios are proportional. Explain.  
(p. 311)

- 2 adults for 10 children and 3 adults for 12 children
- 12 inches by 8 inches and 18 inches by 12 inches
- 8 feet in 21 seconds and 12 feet in 31.5 seconds
- \$5.60 for 5 pairs of socks and \$7.12 for 8 pairs of socks

**Examples 2, 3**  
(pp. 311–312)

Solve each proportion.

$$5. \frac{5}{6} = \frac{t}{18}$$

$$6. \frac{6}{k} = \frac{24}{28}$$

$$7. \frac{21}{5} = \frac{c}{7}$$

$$8. \frac{15}{w} = \frac{2}{5}$$

$$9. \frac{3}{n} = \frac{2.7}{18}$$

$$10. \frac{0.2}{3} = \frac{3}{d}$$

**Example 4**  
(p. 312)

- GROCERIES** Orange juice is on sale at 3 half-gallons for \$5. At this rate, find the cost of 5 half-gallons of orange juice to the nearest cent.
- TRAVEL** Franco drove 203 miles in 3.5 hours. At this rate, how long will it take him to drive another 29 miles to the next town?

## Practice and Problem Solving

### HOMEWORK HELP

For Exercises	See Examples
13–20	1
21–32	2, 3
33–36	4

Determine if the quantities in each pair of ratios are proportional. Explain.

- 20 children from 6 families to 16 children from 5 families
- 5 pounds of dry ice melts in 30 hours and 4 pounds melts in 24 hours
- 16 winners out of 200 entries and 28 winners out of 350 entries
- 5 meters in 7 minutes and 25 meters in 49 minutes
- 1.4 tons produced every 18 days and 10.5 tons every 60 days
- 3 inches for every 4 miles and 7.5 inches for every 10 miles
- READING** Leslie reads 25 pages in 45 minutes. After 60 minutes, she has read a total of 30 pages. Is her time proportional to the number of pages she reads? Explain.
- PETS** A store sells 2 hamsters for \$11 and 6 hamsters for \$33. Is the cost proportional to the number of hamsters sold? Explain.

Solve each proportion.

$$21. \frac{3}{8} = \frac{b}{40}$$

$$22. \frac{x}{12} = \frac{12}{4}$$

$$23. \frac{c}{7} = \frac{18}{42}$$

$$24. \frac{5}{k} = \frac{10}{22}$$

$$25. \frac{3}{8} = \frac{n}{4}$$

$$26. \frac{15}{4} = \frac{3}{8}$$

$$27. \frac{45}{5} = \frac{d}{7}$$

$$28. \frac{30}{a} = \frac{8}{20}$$

$$29. \frac{1.6}{m} = \frac{2}{3}$$

$$30. \frac{4.5}{5} = \frac{t}{7}$$

$$31. \frac{2.5}{4.5} = \frac{7.5}{x}$$

$$32. \frac{3.8}{5.2} = \frac{7.6}{z}$$

- SCHOOL** If 4 notebooks weigh 2.8 pounds, how much do 6 of the same notebooks weigh?
- COOKING** There are 6 teaspoons in 2 tablespoons. How many teaspoons are in 1.5 tablespoons?



35. **SCIENCE** The ratio of salt to water in a certain solution is 4 to 15. If the solution contains 6 ounces of water, how many ounces of salt does it contain?
36. **CONCERTS** Alethia purchased 7 advanced tickets for herself and her friends to a concert and paid \$164.50. If the total cost of tickets to the concert is proportional to the number purchased, how many tickets to the same concert did Serefinia purchase if she paid a total of \$94?

**ANALYZE GRAPHS** For Exercises 37–40, use the graph. It shows the cost of several pizzas, with and without a delivery fee.

37. What do the points (3, 15) and (5, 25) represent on the graph? Is this situation proportional? Explain.
38. What do the points (2, 13) and (4, 23) represent on the graph? Is this situation proportional? Explain.

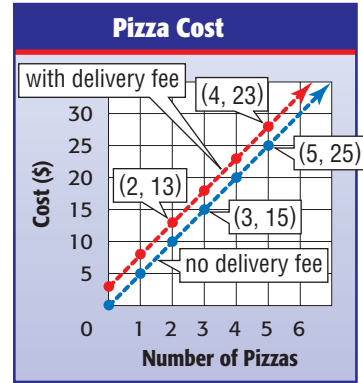

39. What is the slope of each line? What does the slope represent?
40. What is the delivery fee? Explain.
41. **SAVINGS** Pao spent \$140 of his paycheck and put the remaining \$20 in his savings account. If the number of dollars he spends is proportional to the number he saves, how much of a \$156-paycheck will he put into savings?
42. **MOVIES** After 30 seconds, 720 frames of film have passed through a movie projector. At this rate, what is the approximate running time in minutes of a movie made up of 57,000 frames of film?
43. **SCHOOL** There are 325 students and 13 teachers at a school. Next school year, the enrollment is expected to increase by 100 students. Write and solve a proportion to find the number of teachers that must be hired so the student-teacher ratio remains the same.
44. **FIND THE DATA** Refer to the Data File on pages 16–19. Choose some data and write a real-world problem in which you would solve a proportion.



**Real-World Link** . . . . .

Film for an IMAX projection system passes through the projector at the rate of 330 feet per minute or 5.5 feet per second.

Source: IMAX Corporation

**Academic Standards • ISTEP+**  
Extra Practice, pp. 683, 709



**H.O.T. Problems**

45. **Which One Doesn't Belong?** Identify the rate that is not proportional to the other three. Explain your reasoning.

\$4.50 for 5 lb

\$2.88 for 3.2 lb

\$5.70 for 6 lb

\$4.86 for 5.4 lb

46. **CHALLENGE** In a cleaning solution, the ratio of bleach to water is 1:5. If there are 36 cups of cleaning solution, how many cups of water are needed? Explain your reasoning.



47. **SELECT A TECHNIQUE** Sweet corn is on sale at \$2.50 for a dozen at a farmer's market. Select one or more of the following technique(s) to determine how many ears you can buy for \$10. Then use this technique to solve the problem.

mental math

estimation

number sense

48. **WRITING IN MATH** Explain why the cross products of a proportion are equal. Use the term *multiplicative inverse* in your explanation.



**ISTEP+ PRACTICE**

7.1.9, 7.2.7

49. Mirma gives away 84 flyers over a 3-hour period. If the number of flyers she is able to give away per hour remains the same, which proportion can be used to find  $x$ , the number of flyers that she would give away over a 5-hour period?
- A  $\frac{3}{84} = \frac{x}{5}$       C  $\frac{5}{3} = \frac{84}{x}$   
 B  $\frac{84}{3} = \frac{x}{5}$       D  $\frac{3}{84} = \frac{x}{5}$
50. A recipe that makes 16 muffins calls for  $\frac{1}{2}$  cup of flour. How much flour is needed to make 3 dozen muffins using this recipe?
- F  $1\frac{1}{8}$  c  
 G 1 c  
 H  $1\frac{1}{4}$  c  
 J  $1\frac{1}{2}$  c

**Spiral Review**

51. **MEASUREMENT** Felicia bought 5 pounds of onions. About how many kilograms of onions did she buy? (Lesson 6-5)

**MEASUREMENT** Complete. (Lesson 6-4)

52. 5 qt =  pt

53.  $3\frac{1}{2}$  lb =  oz

54. 28 c =  qt

**Multiply. Write in simplest form.** (Lesson 5-5)

55.  $3\frac{1}{2} \times 5\frac{7}{8}$

56.  $1\frac{2}{3} \times 5\frac{4}{5}$

57.  $2\frac{1}{4} \times 7\frac{5}{8}$

**GET READY for the Next Lesson**

58. **PREREQUISITE SKILL** Mr. Andres is filling up his car with gas that costs \$2.50 per gallon. His car's gas gauge before filling up is shown at the right. If his car's gas tank holds 16 gallons, about how much will Mr. Andres pay to fill up his tank? Use the *eliminate possibilities* strategy. (Lesson 5-4)

- A \$15.00      C \$27.00  
 B \$25.00      D \$35.00





## Extend 6-6

# Math Lab Inverse Proportionality

### MAIN IDEA

Graph inverse variations.

### IN Academic Standards

**7.2.7 Identify situations that involve proportional relationships, . . . , and recognize that these situations are described by a linear function in the form  $y = mx$  where the unit rate  $m$  is the slope of the line. Also addresses P.1.1, P.4.1.**

**New Vocabulary**  
**inverse proportion**

Jackie walks at an average rate of 4 miles per hour. This situation can be represented by the equation  $d = 4t$ , where  $d$  is the distance in miles, and  $t$  is the time in hours. The number of miles is proportional to the number of hours because the ratios are equal.

Let's vary the situation a little. Suppose Jackie wants to walk 12 miles each day, at varying speeds. How long will it take her to walk 12 miles? The answer depends on how fast she walks.

### ACTIVITY

**STEP 1** Copy and complete the table for the equation  $12 = rt$ .

$t$ (hours)	12	8	6	■	■	■	■
$r$ (miles per hour)	1	1.5	2	2.5	3	3.5	4

**STEP 2** Copy and complete the graph of the ordered pairs from Step 1. Connect the line with a smooth curve. The first three points are done for you.

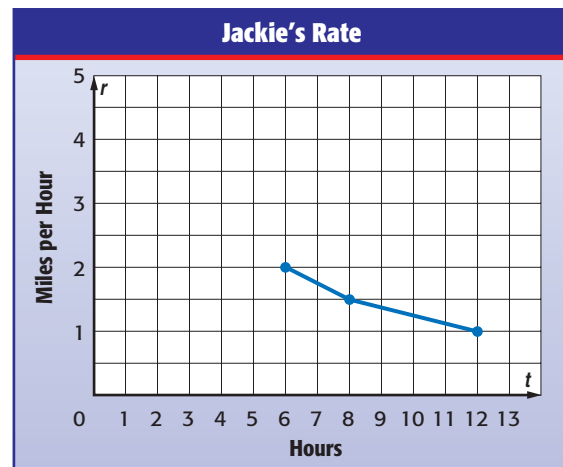

### ANALYZE THE RESULTS

1. Is the time proportional to the rate? Explain why or why not.
2. When the product of two variables is a constant, the relationship forms an **inverse proportion**. Which situation is an inverse proportion: Jackie walking at 4 miles per hour or walking 12 miles at varying rates? Identify the constants in each situation.
3. Mr. Anwar agrees to pay Rob a flat fee of \$240 to do some yard work. Mr. Sloan agrees to pay Rob's brother \$10 per hour to do some yard work. Make a table of ordered pairs and a graph for each situation. Then decide whether each relationship is a proportion or an inverse proportion.

**RECIPE** For Exercises 1–3, use the information in the table to write each ratio as a fraction in simplest form. (Lesson 6-1)

Cherry Punch Recipe	
Cherry Juice	4 cups
Apple Juice	2 cups
Ginger Ale	16 cups

- cherry juice : apple juice
- apple juice : ginger ale
- cherry juice : ginger ale

Determine whether the ratios are equivalent.

Explain. (Lesson 6-1)

- 6 out of 9 words spelled correctly  
2 out of 3 words spelled correctly
- 150 athletes to 15 coaches  
3 athletes to 1 coach
- 24 points in 4 games  
72 points in 8 games



- MULTIPLE CHOICE** Which amount of chocolate shown in the table has the best unit price? (Lesson 6-2)

Weight (oz)	Cost (\$)
12	2.50
18	3.69
24	4.95
30	6.25

- |         |         |
|---------|---------|
| A 12 oz | C 24 oz |
| B 18 oz | D 36 oz |

- Use the graph to find the rate of change in cost per magazine.

(Lesson 6-3)

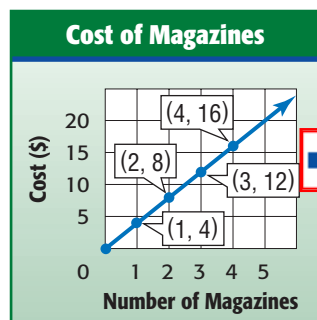

Complete. (Lesson 6-4)

- $42 \text{ ft} = \square \text{ yd}$
- $9 \text{ pt} = \square \text{ qt}$
- $7,600 \text{ lb} = \square \text{ T}$
- $7\frac{1}{2} \text{ gal} = \square \text{ qt}$



- MULTIPLE CHOICE** Which situation is best represented by the graph? (Lesson 6-4)

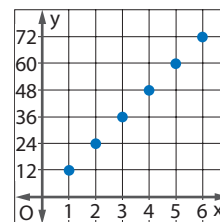

- F conversion of inches to yards  
G conversion of feet to inches  
H conversion of inches to miles  
J conversion of yards to feet

Complete. Round to the nearest hundredth if necessary. (Lesson 6-5)

- $12.5 \text{ mi} \approx \square \text{ km}$
- $4.75 \text{ gal} \approx \square \text{ L}$
- $76 \text{ cm} \approx \square \text{ in.}$
- $31.8 \text{ kg} \approx \square \text{ lb}$

Determine if the quantities in each pair of ratios are proportional. Explain. (Lesson 6-6)

- 8 pages in 5 minutes and 40 pages in 25 minutes
- 40 blank CDs for \$9.60 and 24 blank CDs for \$4.80

Solve each proportion. (Lesson 6-6)

- $\frac{3}{a} = \frac{12}{20}$
- $\frac{7}{8} = \frac{m}{48}$
- $\frac{w}{8} = \frac{1}{3}$



- MEASUREMENT** It took 45 minutes to fill a circular pool of uniform depth to a level of 18 inches. At this rate, how long will it take to fill the pool to a level of 35 inches?

(Lesson 6-6)

**MAIN IDEA:** Solve problems by drawing a diagram.

Academic Standards

**P.1.3** Apply and adapt a variety of appropriate strategies to solve problems. **P.5.1** Create and use representations to organize, record, and communicate mathematical ideas.

## P.S.I. TEAM +

### e-Mail: DRAW A DIAGRAM

**CACEY:** I dropped a ball from a height of 12 feet. It hits the ground and bounces up half as high as it fell. This is true for each successive bounce.

**YOUR MISSION:** Draw a diagram to find the height the ball reaches after the fourth bounce.



<b>Understand</b>	You know the ball is dropped from a height of 12 feet. It bounces up half as high as it falls.
<b>Plan</b>	Draw a diagram to show the height of the ball after each bounce.
<b>Solve</b>	<p>The ball reaches a height of <math>\frac{3}{4}</math> foot after the fourth bounce.</p>
<b>Check</b>	Start at 12 feet. Multiply by $\frac{1}{2}$ for each bounce: $12 \cdot \frac{1}{2} \cdot \frac{1}{2} \cdot \frac{1}{2} \cdot \frac{1}{2} = \frac{12}{16}$ or $\frac{3}{4}$ . So, the solution is correct.

### Analyze The Strategy

- Determine what height a ball would reach after the fourth bounce if it is dropped from 12 feet and bounces up  $\frac{2}{3}$  as high. Draw a new diagram for this situation.
- WRITING IN MATH** Write a problem that could be solved by drawing a diagram. Exchange your problem with a classmate and solve.

Solve Exercises 3–5. Use the *draw a diagram* strategy.

- TRAVEL** Mr. Garcia has driven 60 miles, which is  $\frac{2}{3}$  of the way to his sister's house. How much farther does he have to drive to get to his sister's house?
- DISTANCE** Alejandro and Pedro are riding their bikes to school. After 1 mile, they are  $\frac{4}{5}$  of the way there. How much farther do they have to go?
- VOLUME** A swimming pool is being filled with water. After 25 minutes,  $\frac{1}{6}$  of the swimming pool is filled. How much longer will it take to completely fill the pool, assuming the water rate is constant?



Use any strategy to solve Exercises 6–10. Some strategies are shown below.

PROBLEM-SOLVING STRATEGIES

- Work backward.
- Make an organized list.
- Eliminate possibilities.
- Draw a diagram.

- BASEBALL** Of Lee's baseball cards,  $\frac{1}{5}$  show California players. Of these,  $\frac{3}{8}$  show San Diego Padres players. Is the fraction of Lee's collection that show Padres players  $\frac{23}{40}$ ,  $\frac{4}{13}$ , or  $\frac{3}{40}$ ?



- GAMES** Eight members of a chess club are having a tournament. In the first round, every player will play a chess game against every other player. How many games will be in the first round of the tournament?
- MEASUREMENT** Kiaya is adding a 2-inch border to the length and width of a photograph as shown.

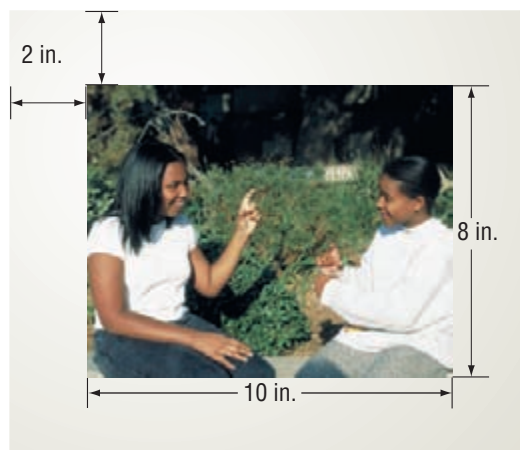

Which expression represents the area of the border to be added to the original photograph?

- $(8 + 4)(10 + 4)$
  - $(8 + 4)(10 + 4) - (8)(10)$
  - $(8 - 4)(10 - 4)$
  - $(8 - 4)(10 - 4) - (8)(10)$
- RACES** Anna, Isabela, Mary, and Pilar ran a race. Anna is just ahead of Pilar. Pilar is two places behind Isabela. Isabela is a few seconds behind the leader, Mary. Use the table to place the girls in order from first to last.
  - FRACTIONS** Marta ate a quarter of a whole pie. Edwin ate  $\frac{1}{4}$  of what was left. Cristina then ate  $\frac{1}{3}$  of what was left. What fraction of the pie remains?



# 6-8

# Scale Drawings

## MAIN IDEA

Solve problems involving scale drawings.

## IN Academic Standards

**7.3.5 Identify, describe and construct similarity relationships and solve problems involving similarity** (including similar triangles) and **scale drawings by using proportional reasoning.** Also addresses P.1.2, P.4.3.

## New Vocabulary

scale drawing  
scale model  
scale  
scale factor

## IN Math Online

[glencoe.com](http://glencoe.com)

- Concepts In Motion
- Extra Examples
- Personal Tutor
- Self-Check Quiz

## MINI Lab

- Measure the length of each item in a room, such as a gymnasium.
  - Record each length to the nearest  $\frac{1}{2}$  foot.
1. Let 1 unit on the grid paper represent 2 feet. So, 4 units = 8 feet. Convert all your measurements to units.
  2. On grid paper, make a drawing of your gymnasium like the one shown at the right.

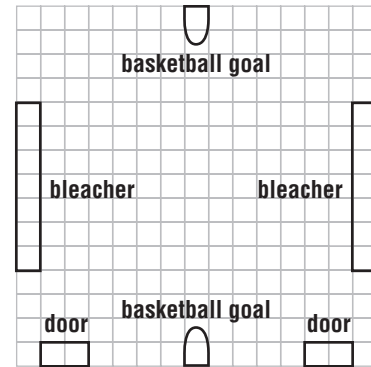

A map is an example of a scale drawing. **Scale drawings** and **scale models** are used to represent objects that are too large or too small to be drawn or built at actual size. The **scale** gives the ratio that compares the measurements of the drawing or model to the measurements of the real object. The measurements on a drawing or model are proportional to measurements of the actual object.

## EXAMPLE Use a Map Scale

**1 MAPS** What is the actual distance between Hagerstown and Annapolis?

**Step 1** Use a centimeter ruler to find the map distance between the two cities. The map distance is about 4 centimeters.



**Step 2** Write and solve a proportion using the scale. Let  $d$  represent the actual distance between the cities.

$$\begin{array}{rcc}
 \text{Scale} & & \text{Length} \\
 \text{map} \rightarrow & \frac{1 \text{ centimeter}}{24 \text{ miles}} = & \frac{4 \text{ centimeters}}{d \text{ miles}} \leftarrow \text{map} \\
 \text{actual} \rightarrow & & \leftarrow \text{actual} \\
 1 \times d = 24 \times 4 & & \text{Cross products} \\
 d = 96 & & \text{Simplify.}
 \end{array}$$

The distance between the cities is about 96 miles.



### Study Tip

**Scale** A map scale can be written in different ways, including the following:

$$1 \text{ cm} = 20 \text{ mi}$$

$$1 \text{ cm} : 20 \text{ mi}$$

$$\frac{1 \text{ cm}}{20 \text{ mi}}$$

### CHECK Your Progress

- a. **MAPS** On the map of Arkansas shown, find the actual distance between Clarksville and Little Rock. Use a ruler to measure.



A blueprint is another example of a scale drawing.

### EXAMPLE Use a Blueprint Scale

- 2 **DECKS** On the blueprint of the deck, each square has a side length of  $\frac{1}{2}$  inch. What is the actual width of the deck?

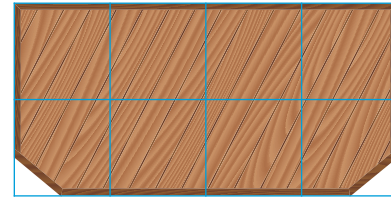

Scale  
 $\frac{1}{2}$  in. = 4 ft

The deck on the blueprint is 2 inches wide. Write and solve a proportion using the scale. Let  $w$  represent the actual width of the deck.

### Study Tip

**Scales** Scales and scale factors are always written so that the drawing length comes first in the ratio.

$$\begin{array}{l} \text{Scale} \\ \text{Width} \\ \text{blueprint} \rightarrow \frac{\frac{1}{2} \text{ inch}}{4 \text{ feet}} = \frac{2 \text{ inches}}{w \text{ feet}} \leftarrow \text{blueprint} \\ \text{actual} \rightarrow \end{array}$$

$$\frac{1}{2} \times w = 4 \times 2$$

Cross products

$$\frac{1}{2}w = 8$$

Multiply.

$$w = 16$$

Simplify. Multiply each side by 2.



The actual width of the deck is 16 feet.

### CHECK Your Progress

- b. **INTERIOR DESIGN** On the blueprint of the living room, each square has a side length of  $\frac{1}{4}$  inch. What are the actual dimensions of the living room?

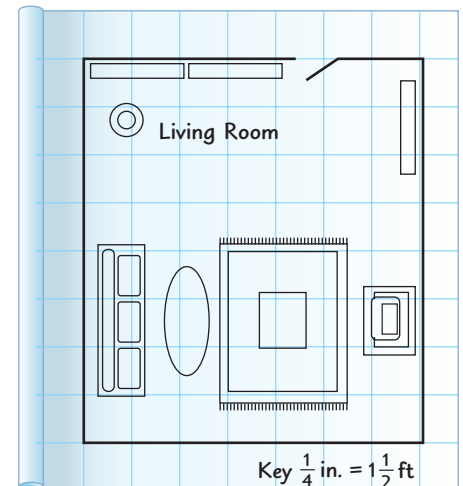



### Study Tip

**Scale** The scale is the ratio of the drawing/model measure to the actual measure. It is not always the ratio of a smaller measure to a larger measure.

## EXAMPLE Use a Scale Model

- 3 PHONES** A graphic artist is creating an advertisement for a new cell phone. If she uses a scale of 5 inches = 1 inch, what is the length of the cell phone on the advertisement?



$$\begin{array}{ccccc} & \text{Scale} & & \text{Length} & \\ \text{advertisement} \rightarrow & \frac{5 \text{ inches}}{1 \text{ inch}} & = & \frac{a \text{ inches}}{4 \text{ inches}} & \leftarrow \text{advertisement} \\ \text{actual} \rightarrow & & & & \leftarrow \text{actual} \end{array}$$

$$5 \cdot 4 = 1 \cdot a \quad \text{Cross products}$$

$$20 = a \quad \text{Multiply.}$$

The length of the cell phone on the advertisement is 20 inches long.

### ✓ CHECK Your Progress

- c. **SCOOTERS** A scooter is  $3\frac{1}{2}$  feet long. Find the length of a scale model of the scooter if the scale is 1 inch =  $\frac{3}{4}$  feet.

In Lesson 6-4, you used ratios to convert units. You can use a similar method to simplify a scale. A scale written as a ratio without units in simplest form is called the **scale factor**.

$$\text{scale} \rightarrow \frac{\frac{1}{4} \text{ inch}}{2 \text{ feet}} = \frac{\frac{1}{4} \text{ inch}}{24 \text{ inches}}$$

$$= \frac{4}{4} \cdot \frac{\frac{1}{4} \text{ inch}}{24 \text{ inches}}$$

$$= \frac{1}{96} \quad \text{scale factor}$$

Convert 2 feet to inches.

Multiply by  $\frac{4}{4}$  to eliminate the fraction in the numerator. Divide out the common units.

## EXAMPLE Find a Scale Factor

- 4 SAILBOATS** Find the scale factor of a model sailboat if the scale is 1 inch = 6 feet.

$$\frac{1 \text{ inch}}{6 \text{ feet}} = \frac{1 \text{ inch}}{72 \text{ inches}} \quad \text{Convert 6 feet to inches.}$$

$$= \frac{1}{72} \quad \text{Divide out the common units.}$$

The scale factor is  $\frac{1}{72}$ .

### ✓ CHECK Your Progress

- d. **CARS** What is the scale factor of a model car if the scale is 1 inch = 2 feet?

### Study Tip

**Equivalent Scales** The scales below are equivalent because their scale factors are equal,  $\frac{1}{72}$ .

- 1 inch = 6 feet
- $\frac{1}{2}$  inch = 3 feet

# CHECK Your Understanding

**Example 1**  
(pp. 320–321)

**GEOGRAPHY** Find the actual distance between each pair of cities in New Mexico. Use a ruler to measure.

1. Carlsbad and Artesia
2. Hobbs and Eunice
3. Artesia and Eunice
4. Lovington and Carlsbad



**Example 2**  
(p. 321)

**BLUEPRINTS** For Exercises 5 and 6, use the blueprint. Each square has a side length of  $\frac{1}{4}$  inch.

5. What is the actual length of the pool?
6. What is the actual width of the pool?

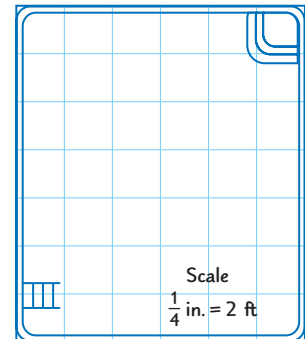

**Example 3**  
(p. 322)

**BRIDGES** For Exercises 7 and 8, use the following information.

An engineer makes a model of the bridge using a scale of 1 inch = 3 yards.

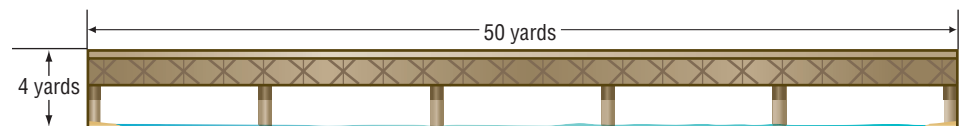

7. What is the length of the model?
8. What is the height of the model?

**Example 4**  
(p. 322)

Find the scale factor of each scale drawing or model.

9.



1 inch = 4 feet

10.

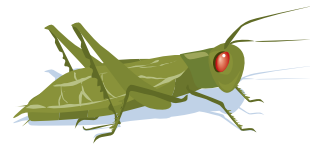

1 centimeter = 15 millimeters

11. **CITY PLANNING** In the aerial view of a city block at the right, the length of Main Street is 2 inches. If Main Street's actual length is 2 miles, find the scale factor of the drawing.

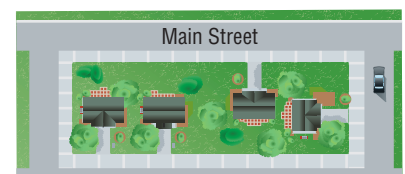





# Practice and Problem Solving

## HOMWORK HELP

For Exercises	See Examples
12–15	1
16–17	2
18–24	3, 4

**GEOGRAPHY** Find the actual distance between each pair of locations in South Carolina. Use a ruler to measure.



- 12. Columbia and Charleston
- 13. Hollywood and Sumter
- 14. Congaree Swamp and Charleston
- 15. Sumter and Columbia

For Exercises 16–18, use the blueprint of an apartment at the right. Each square has a side length of  $\frac{1}{4}$  inch.

- 16. What is the actual length of the living room?
- 17. Find the actual dimensions of the master bedroom.
- 18. Find the scale factor for this blueprint.

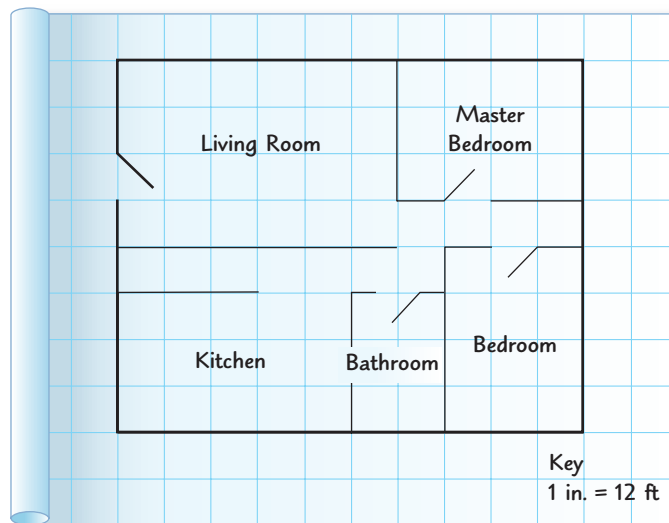

Find the length of each model. Then find the scale factor.

19. 87 ft  
2 in. = 15 ft

20. 36 m  
0.5 cm = 1.5 m

21. 120 yd  
1 in. = 20 yd

22.  $5\frac{7}{8}$  in.  
1 in. = 0.5 in.



### Real-World Link . . .

The statue of Thomas Jefferson inside the Jefferson Memorial in Washington, D.C., was made using a scale of 3 feet : 1 foot.

Source: National Register of Historic Places

23. **GEOGRAPHY** A map of Bakersfield, California, has a scale of 1 inch to 5 miles. If the city is  $5\frac{1}{5}$  inches across on the map, what is the actual distance across the actual city? Use estimation to check your answer.
24. **TREES** A model of a tree is made using a scale of 1 inch : 25 feet. What is the height of the actual tree if the height of the model is  $4\frac{3}{8}$  inches?
25. **STATUES** Refer to the information at the left. Find the scale factor and the actual height of Thomas Jefferson if the height of the statue is 19 feet.
26. **GEOGRAPHY** Lexington and Elizabethtown, Kentucky, are 79 miles apart. If the distance on the map is  $2\frac{1}{2}$  inches, find the scale of the map.
27. **RESEARCH** Find the dimensions of any U.S. presidential monument. Give an appropriate scale that can be used to make a scale model of the monument. State the dimensions of the model using your scale.
28. **BUILDINGS** If you are making a model of your bedroom, which would be an appropriate scale: 1 inch = 2 feet, or 1 inch = 12 feet?
29. **LIFE SCIENCE** A scale drawing of a red blood cell is shown below. If the blood cell's actual diameter is 0.008 millimeter, use a ruler to find the scale factor of the drawing.

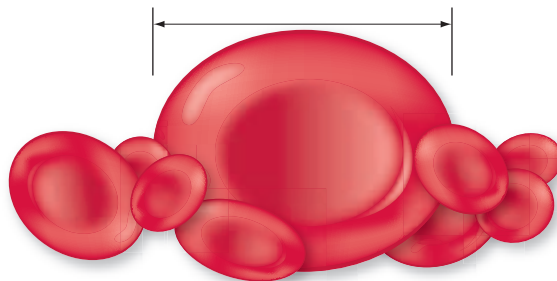

Academic Standards • ISTEP+

Extra Practice, pp. 684, 709



### H.O.T. Problems

30. **OPEN ENDED** On grid paper, create a scale drawing of a room in your home. Include the scale that you used.
31. **CHALLENGE** Montoya constructed three models, A, B, and C, of the same figure, with scales of  $0.5 \text{ cm} = 1 \text{ mm}$ ,  $1.5 \text{ mm} = 4 \text{ cm}$ , and  $0.25 \text{ cm} = 2.5 \text{ mm}$ , respectively.
  - a. Which model is larger than the actual figure? Justify your answer.
  - b. Which model is smaller than the actual figure? Justify your answer.
  - c. Which model is the same size as the actual figure? Justify your answer.
32. **REASONING** Compare and contrast the terms *scale* and *scale factor*. Include an example in your comparison.
33. **WRITING IN MATH** Explain how you could use estimation to find the actual distance between San Diego, California, and Seattle, Washington, on a map.

## ISTEP+ PRACTICE

7.3.5

34. A scale drawing of a doctor's office is shown.

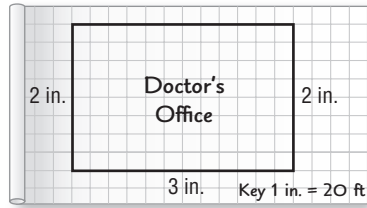

What are the actual dimensions of the doctor's office?

- A 24 feet by 48 feet
- B 30 feet by 52 feet
- C 40 feet by 60 feet
- D 37.5 feet by 65 feet

35. A certain map has a scale of  $\frac{1}{4}$  inch = 30 miles. How many miles are represented by 4 inches on this map?

- F 480 miles
- G 120 miles
- H 30 miles
- J 16 miles

36. Ernesto drew a map of his school. He used a scale of 1 inch : 50 feet. What distance on Ernesto's map should represent the 625 feet between the cafeteria and the science lab?

- A 8 in.
- B 10.5 in.
- C 12.5 in.
- D 15 in.

## Spiral Review

37. **FAMILY** At Nelia's family reunion,  $\frac{4}{5}$  of the people are 18 years of age or older. Half of the remaining people are under 12 years old. If 20 children are under 12 years old, how many people are at the reunion? Use the *draw a diagram* strategy. (Lesson 6-7)

Solve each proportion. (Lesson 6-6)

38.  $\frac{5}{7} = \frac{a}{35}$

39.  $\frac{12}{p} = \frac{36}{45}$

40.  $\frac{3}{9} = \frac{21}{k}$

41. **JOGGING** The table shows the number of miles Tonya jogged each week for the past several weeks. Estimate the total number of miles she jogged. (Lesson 5-1)

Week	Miles
1	$7\frac{1}{6}$
2	$8\frac{3}{4}$
3	10
4	$12\frac{1}{4}$
5	$6\frac{2}{3}$

Find the LCM of each set of numbers. (Lesson 4-8)

42. 2, 4

43. 4, 8, 12

44. 3, 7, 5

45. 5, 10, 15

46. 2, 6, 9

47. 3, 15, 20

## GET READY for the Next Lesson

**PREREQUISITE SKILL** Divide. Write in simplest form. (Lesson 5-7)

48.  $2\frac{3}{4} \div 10$

49.  $4\frac{1}{3} \div 10$

50.  $30\frac{2}{3} \div 100$

51.  $87\frac{1}{2} \div 100$

## Extend 6-8

# Spreadsheet Lab Scale Drawings

### MAIN IDEA

Use a spreadsheet to calculate measurements for scale drawings.

### IN Academic Standards

**7.3.5** Identify, describe and construct similarity relationships and solve problems involving similarity (including similar triangles) and scale drawings by using proportional reasoning. Also addresses P.1.2, P.4.3, P.7.1.

A computer spreadsheet is a useful tool for calculating measures for scale drawings. You can change the scale factors and the dimensions, and the spreadsheet will automatically calculate the new values.

### ACTIVITY

Suppose you want to make a scale drawing of your school. Set up a spreadsheet like the one shown below. In this spreadsheet, the actual measures are in feet, and the scale drawing measures are in inches.

	A	B	C
1	Actual	Scale	Scale Drawing
2	Measure (ft)	Factor	Measure (in.)
3	5	60	1.0
4	30	100	3.6
5	100	250	4.8
6			
7			

Formula bar: C3 = =(A3\*12)/B3

Callout 1: Multiply each actual measure by 12 to convert to inches. Then divide by the scale factor.

Callout 2: The scale factor 100 means that the ratio of drawing measures to actual measures is 1:100.

## ANALYZE THE RESULTS

1. The length of one side of the school building is 100 feet. If you use a scale factor of 1 : 250, what is the length on your scale drawing?
2. The length of a classroom is 30 feet. What is the scale factor if the length of the classroom on a scale drawing is 3.6 inches?
3. Calculate the length of a 30-foot classroom on a scale drawing if the scale factor is 1 : 10.
4. The width of a hallway is 20 feet. What is the scale factor if the width of the hallway on a scale drawing is 2.5 inches?
5. Suppose the actual measures of your school are given in meters. Describe how you could use a spreadsheet to calculate the scale drawing measures in centimeters using a scale factor of 1 : 50.
6. Choose three rooms in your home and use a spreadsheet to make scale drawings. First, choose an appropriate scale and calculate the scale factor. Include a sketch of the furniture drawn to scale in each room.



# Fractions, Decimals, and Percents

## MAIN IDEA

Write percents as fractions, and decimals and vice versa.

## IN Academic Standards

**7.1.6** Identify, write, **rename**, compare and order **rational** and common irrational **numbers** and plot them on a number line. *Also addresses P.4.2.*

## IN Math Online

[glencoe.com](http://glencoe.com)

- Extra Examples
- Personal Tutor
- Self-Check Quiz

## ▶ GET READY for the Lesson

**SURVEYS** The graph shows the results of a survey about favorite type of TV show.

1. What percent of the teens chose comedy?
2. Write this percent as a ratio in simplest form.

Types of Shows Teens Spend the Most Time Watching

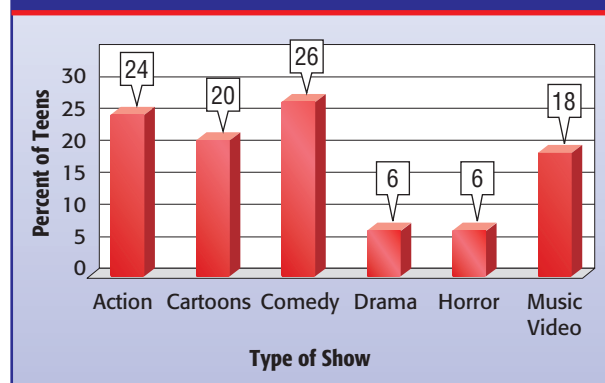

Source: Kids USA Survey

In Lesson 4-6, you wrote percents like 26% as fractions by writing fractions with denominators of 100 and then simplifying. You can use the same method to write percents like  $8\frac{1}{3}\%$  and 190% as fractions.

## EXAMPLES Percents as Fractions

- 1** Write  $8\frac{1}{3}\%$  as a fraction in simplest form.

$$\begin{aligned}
 8\frac{1}{3}\% &= \frac{8\frac{1}{3}}{100} && \text{Write a fraction.} \\
 &= 8\frac{1}{3} \div 100 && \text{Divide.} \\
 &= \frac{25}{3} \div 100 && \text{Write } 8\frac{1}{3} \text{ as an improper fraction.} \\
 &= \frac{25}{3} \cdot \frac{1}{100} && \text{Multiply by the reciprocal of 100, which is } \frac{1}{100}. \\
 &= \frac{25}{300} \text{ or } \frac{1}{12} && \text{Simplify.}
 \end{aligned}$$

- 2 TOYS** A collectible action figure sold for 190% of its original price. Write this percent as a fraction in simplest form.

$$\begin{aligned}
 190\% &= \frac{190}{100} && \text{Definition of percent} \\
 &= \frac{19}{10} \text{ or } 1\frac{9}{10} && \text{Simplify.}
 \end{aligned}$$

A percent greater than 100 is equal to a number greater than 1.

So, the toy sold for  $1\frac{9}{10}$  of its original price.



### ✓ CHECK Your Progress

Write each percent as a fraction in simplest form.

a. 150%

b.  $17\frac{1}{2}\%$

c.  $33\frac{1}{3}\%$

To write a fraction like  $\frac{8}{25}$  as a percent, multiply the numerator and the denominator by a number so that the denominator is 100. If the denominator is not a factor of 100, you can write fractions as percents by using a proportion.

### Study Tip

**Choose the Method**  
To write a fraction as a percent,

- use multiplication when a fraction has a denominator that is a factor of 100,
- use a proportion for any type of fraction.

### EXAMPLES Fractions as Percents

**3** Write  $\frac{4}{15}$  as a percent. Round to the nearest hundredth.

**Estimate**  $\frac{4}{15}$  is about  $\frac{4}{16}$ , which equals  $\frac{1}{4}$  or 25%.

$$\frac{4}{15} = \frac{n}{100} \quad \text{Write a proportion.}$$

$$400 = 15n \quad \text{Find the cross products.}$$

$$\frac{400}{15} = \frac{15n}{15} \quad \text{Divide each side by 15.}$$

$$26.67 \approx n \quad \text{Simplify.}$$

So,  $\frac{4}{15}$  is about 26.67%.

**Check for Reasonableness**  $26.67\% \approx 25\%$  ✓

**4** **BLOGGING** In Boston,  $\frac{89}{100,000}$  residents blog. Write this fraction as a percent.

$$\frac{89}{100,000} = \frac{n}{100} \quad \text{Write a proportion.}$$

$$8,900 = 100,000n \quad \text{Find the cross products.}$$

$$\frac{8,900}{100,000} = \frac{100,000n}{100,000} \quad \text{Divide each side by 100,000.}$$

$$0.089 = n \quad \text{Simplify.}$$

So, 0.089% of Boston's residents blog.

A percent less than 1% is equal to a number less than 0.01 or  $\frac{1}{100}$ .

### ✓ CHECK Your Progress

Write each fraction as a percent. Round to the nearest hundredth if necessary.

d.  $\frac{2}{15}$

e.  $\frac{7}{1,600}$

f.  $\frac{17}{25}$



### Study Tip

**Look Back** You can review writing fractions as decimals in lesson 4-3.

In this lesson, you have written percents as fractions and fractions as percents. In Chapter 4, you wrote percents and fractions as decimals. You can also write a fraction as a percent by first writing the fraction as a decimal and then writing the decimal as a percent.

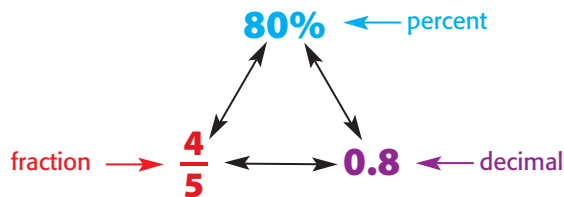

Percents, fractions, and decimals are different names that represent the same number.

## EXAMPLES Fractions as Percents

- 5** Write  $\frac{5}{6}$  as a percent. Round to the nearest hundredth.

$$\frac{5}{6} = 0.833333333 \dots \quad \text{Write } \frac{5}{6} \text{ as a decimal.}$$

$$\approx 83.33\% \quad \text{Multiply by 100 and add the \% .}$$

- 6 BOOKS** Bryce has read  $\frac{3}{5}$  of a book. What percent of the book has he read?

$$\frac{3}{5} = 0.6 \quad \text{Write the fraction as a decimal.}$$

$$= 60\% \quad \text{Multiply by 100 and add the \% .}$$

So, Bryce has read 60% of the book.

### CHECK Your Progress

Write each fraction as a percent. Round to the nearest hundredth if necessary.

g.  $\frac{5}{16}$

h.  $\frac{7}{12}$

i.  $\frac{2}{9}$

- j. **LAWNS** Mika is mowing lawns to earn extra money. She has mowed 6 out of 13 lawns. What percent of the lawns has she mowed?

Some fractions with denominators that are not factors of 100 are used often in everyday situations. It is helpful to memorize these fractions and their equivalent decimals and percents. These common equivalents are shown below.

Common Equivalents			Key Concept		
Fraction	Decimal	Percent	Fraction	Decimal	Percent
$\frac{1}{3}$	$0.\bar{3}$	$33\frac{1}{3}\%$	$\frac{3}{8}$	0.375	$37\frac{1}{2}\%$
$\frac{2}{3}$	$0.\bar{6}$	$66\frac{2}{3}\%$	$\frac{5}{8}$	0.625	$62\frac{1}{2}\%$
$\frac{1}{8}$	0.125	$12\frac{1}{2}\%$	$\frac{7}{8}$	0.875	$87\frac{1}{2}\%$



## CHECK Your Understanding

**Examples 1, 2**  
(pp. 328–329)

Write each percent as a fraction in simplest form.

1. 135%
2. 18.75%
3.  $7\frac{1}{2}\%$
4.  $66\frac{2}{3}\%$
5. **FOOD** Steven and Rebecca ate 62.5% of a pizza. What fraction of the pizza did they eat?

**Examples 3–5**  
(pp. 329–330)

Write each fraction as a percent. Round to the nearest hundredth if necessary.

6.  $\frac{3}{4}$
7.  $\frac{4}{2,500}$
8.  $\frac{4}{11}$
9.  $\frac{1}{9}$

**Example 6**  
(p. 330)

10. **SCHOOL** Moses has finished 11 out of 15 homework questions. To the nearest hundredth, what percent of the homework is complete?

## Practice and Problem Solving

### HOMEWORK HELP

For Exercises	See Examples
11–14, 19	1
15–18, 20	2
21–32	3–6
33–34	3

Write each percent as a fraction in simplest form.

11. 62.5%
12. 6.2%
13. 28.75%
14. 56.25%
15.  $33\frac{1}{3}\%$
16.  $16\frac{2}{3}\%$
17.  $93\frac{3}{4}\%$
18.  $78\frac{3}{4}\%$

19. **ENVIRONMENT** Freshwater from lakes only accounts for 0.1% of the world's water supply. Write this percent as a fraction in simplest form.
20. **ATTENDANCE** At last year's spring dance,  $78\frac{1}{3}\%$  of the student body attended. What fraction of the student body is this?

Write each fraction as a percent. Round to the nearest hundredth if necessary.

21.  $\frac{111}{20}$
22.  $\frac{180}{25}$
23.  $\frac{30}{8}$
24.  $\frac{210}{40}$
25.  $\frac{29}{30}$
26.  $\frac{8}{9}$
27.  $\frac{5}{7}$
28.  $\frac{1}{16}$
29.  $\frac{1}{800}$
30.  $\frac{57}{20,000}$
31.  $\frac{5}{1,200}$
32.  $\frac{7}{1,500}$

33. **FOOD** The size of a large milkshake is  $\frac{7}{5}$  times the size of a medium milkshake. Write  $\frac{7}{5}$  as a percent.
34. **PETS** In a class, 28 out of 32 students had a pet. What percent is this?

Replace each  $\bullet$  with  $>$ ,  $<$ , or  $=$  to make a true statement.

35.  $0.86 \bullet \frac{7}{8}$
36.  $\frac{9}{20} \bullet 45\%$
37.  $5\% \bullet 0.004$

Order each set of numbers from least to greatest.

38.  $\frac{1}{4}$ , 22%, 0.3, 0.02
39. 0.48,  $\frac{1}{2}\%$ , 0.5,  $\frac{2}{5}$

40. **GEOGRAPHY** Use the information at the left. What percent of the states in the United States do *not* border an ocean or the Gulf of Mexico?



### Real-World Link . . . . .

Out of the 50 states, 23 states border an ocean or the Gulf of Mexico.

Source: The US50





41. **FIND THE DATA** Refer to the Data File on pages 16–19. Choose some data and write a real-world problem in which you would write a fraction as a percent.

**CARS** For Exercises 42 and 43, use the table, which shows the percent of people in a recent survey who kept the listed items in their car.

Items in Car	Percent of People
Pen/Pencil	73.0%
Cassette Tapes/CDs	66.1%
First-Aid Kit	38.2%
Sports Equipment	28.9%

42. What fraction of people kept a first-aid kit in their car?
43. Approximately 26 out of 125 people surveyed kept a hairbrush in their car. Is this greater or less than the percent who kept sports equipment? Explain.

Academic Standards • ISTEP+

Extra Practice, pp. 684, 709

**H.O.T. Problems**

44. **CHALLENGE** For what value of  $x$  does  $\frac{1}{x} = x\%$ ?
45. **WRITING IN MATH** Explain why 80%, 0.8, and  $\frac{4}{5}$  all represent the same value.

**ISTEP+ PRACTICE** 7.1.6

46. Ms. Gallagher made 64 ounces of punch. The punch contained 17 ounces of apple juice. Which equation can be used to find  $x$ , the percent of apple juice in the punch?

- A  $\frac{x}{100} = \frac{64}{17}$
- B  $\frac{x}{17} = \frac{64}{100}$
- C  $\frac{x}{64} = \frac{17}{100}$
- D  $\frac{x}{100} = \frac{17}{64}$

47. A group of 150 students were asked if they own a pet. The results are shown.

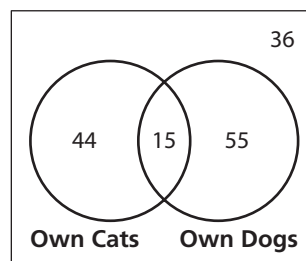

What percent of those surveyed own dogs?

- F 50%                  H 36.7%
- G 46.7%                J 30%

**Spiral Review**

48. **COMPUTERS** Designers are creating a larger model of the computer memory board. They use a scale of 20 inches = 1 inch. If the actual board is  $5\frac{1}{4}$  inches long, what is the length of the model? (Lesson 6-8)
49. **RECIPES** Camila is making soup. She has added  $\frac{2}{3}$  of the ingredients. If she has added 4 ingredients, how many more does she have to add to be finished? (Lesson 6-7)

**GET READY for the Next Lesson**

**PREREQUISITE SKILL** Write each fraction in simplest form. (Lesson 4-4)

50.  $\frac{8}{10}$                       51.  $\frac{45}{100}$                       52.  $\frac{450}{100}$                       53.  $\frac{175}{100}$

FOLDABLES  
Study Organizer

## ▶ GET READY to Study

Be sure the following Big Ideas are noted in your Foldable.

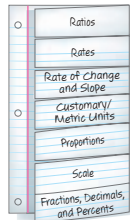

## BIG Ideas

**Ratios and Rates** (Lessons 6-1 and 6-2)

- A ratio is a comparison of two quantities by division.
- A rate is a ratio comparing two quantities with different kinds of units.

**Slope and Rate of Change** (Lesson 6-3)

- Slope is the rate of change between any two points on a line.

**Changing Customary Units** (Lesson 6-4)

- To convert from larger units to smaller units, multiply by the appropriate unit ratio.
- To convert from smaller units to larger units, multiply by the reciprocal of the appropriate unit ratio.

**Changing Metric Units** (Lesson 6-5)

- When converting metric units, multiply by the appropriate power of 10.
- When converting between customary and metric units, use the appropriate unit ratio or relationship.

**Proportions** (Lesson 6-6)

- Proportions are equations that state two ratios or rates are equivalent.

**Scale Drawings** (Lesson 6-8)

- Scale drawings represent something that is too large or too small to be drawn at actual size.

## Key Vocabulary

- |                                    |                               |
|------------------------------------|-------------------------------|
| <b>cross products</b> (p. 310)     | <b>scale</b> (p. 320)         |
| <b>equivalent ratios</b> (p. 283)  | <b>scale drawing</b> (p. 320) |
| <b>inverse proportion</b> (p. 316) | <b>scale factor</b> (p. 322)  |
| <b>proportion</b> (p. 310)         | <b>scale model</b> (p. 320)   |
| <b>proportional</b> (p. 310)       | <b>slope</b> (p. 294)         |
| <b>rate</b> (p. 287)               | <b>unit rate</b> (p. 287)     |
| <b>rate of change</b> (p. 293)     | <b>unit ratio</b> (p. 299)    |
| <b>ratio</b> (p. 282)              |                               |

## Vocabulary Check

Choose the term from the list above that best matches each phrase.

1. a comparison of two quantities by division
2. two ratios that have the same value
3. a ratio of two measurements with different units
4. an equation that shows that two ratios or rates are equivalent
5. used to represent something that is too large or too small for an actual-size drawing
6. the ratio of the distance on a map to the actual distance
7. a scale written as a ratio in simplest form without units of measurement
8. the constant rate of change in  $y$  with respect to the constant change in  $x$
9. a rate that is simplified so that it has a denominator of 1
10. two quantities that have a constant rate or ratio

## Lesson-by-Lesson Review

## 6-1

## Ratios (pp. 282–286)



7.1.9

Write each ratio as a fraction in simplest form.

11. 16 dogs:12 cats    12. 5 ft:25 ft

13. 50 boys:75 girls    14. 36 ft:6 ft.

15. Determine whether the ratios 18 out of 24 and 5 out of 20 are equivalent.

**Example 1** Write the ratio 32 to 18 as a fraction in simplest form.

$$32 \text{ to } 18 = \frac{32}{18} \quad \text{Write the ratio as a fraction.}$$

$$= \frac{16}{9} \quad \text{Simplify.}$$

**Example 2** Determine whether 5:6 and 15:18 are equivalent.

$$5:6 = \frac{5}{6} \quad 15:18 = \frac{15}{18} \text{ or } \frac{5}{6}$$

The ratios in simplest form both equal  $\frac{5}{6}$ .  
So, 5:6 and 15:18 are equivalent.

## 6-2

## Rates (pp. 287–292)



7.1.9

Find each unit rate.

16. \$23.75 for 5 pounds

17. 810 miles in 9 days

18. **SHAMPOO** Which bottle of shampoo shown at the right costs the least per ounce?

Bottle	Price
8 oz	\$1.99
12 oz	\$2.59
16 oz	\$3.19

**Example 3** Find the unit price of a 16-ounce box of pasta that is on sale for 96 cents.

$$16\text{-ounce box for 96 cents} = \frac{96 \text{ cents} \div 16}{16 \text{ ounces} \div 16}$$

$$= \frac{6 \text{ cents}}{1 \text{ ounce}}$$

The unit price is 6 cents per ounce.

## 6-3

## Rate of Change and Slope (pp. 293–297)

7.2.5,  
7.2.6

Complete.

19. **MONEY** The table shows the amount of money José saved over a period of time. Graph the data. Then find the slope of the line. Explain what the slope represents.

Amount (\$)	30	60	90
Weeks	1	2	3

**Example 4** Find the rate of change in degrees per hour.

Time (h)	0	1	2
Temperature (C°)	50	52	54

$\xrightarrow{+1}$      $\xrightarrow{+1}$   
 $\xleftarrow{+2}$      $\xleftarrow{+2}$

$$\frac{\text{change in temperature}}{\text{change in time}} = \frac{2^\circ \text{ Celsius}}{1 \text{ hour}}$$

So, the temperature increases by  $2^\circ$  Celsius each hour.

**6-4 Measurement: Changing Customary Units** (pp. 298–303)



8.3.4

Complete.

20. 4 qt = ■ pt      21. 6 gal = ■ qt

22. 48 oz = ■ lb      23. 9 c = ■ pt

24. **RUNNING** Kimi runs at a speed of 30 feet per second. About how many yards per second does Kimi run?

25. **ESTIMATION** One bushel of apples weighs about 40 pounds. About how many bushels of apples would weigh 1 ton?

**Example 5** Complete: 32 qt = ■ gal

Since 1 gallon = 4 quarts, multiply by  $\frac{1 \text{ gal}}{4 \text{ qt}}$ .

$$32 \text{ qt} = 32 \text{ qt} \cdot \frac{1 \text{ gal}}{4 \text{ qt}} \quad \text{Multiply by } \frac{1 \text{ gal}}{4 \text{ qt}}.$$

$$= \overset{8}{\cancel{32}} \text{ qt} \cdot \frac{1 \text{ gal}}{\underset{1}{\cancel{4}} \text{ qt}} \quad \text{Divide out common factors and units.}$$

$$= 8 \text{ gal} \quad \text{Multiply.}$$

**6-5 Measurement: Changing Metric Units** (pp. 304–309)



8.3.4

Complete. Round to the nearest hundredth if necessary.

26. 18.25 ft  $\approx$  ■ m      27. 113.6 lb  $\approx$  ■ g

28. 24 L  $\approx$  ■ gal      29. 46.8 cm  $\approx$  ■ in.

30. **RUNNING** Justine ran a 5-kilometer race. About how many miles did she run?

31. **BIRDS** The world's largest bird is the ostrich, whose mass can be as much as 156.5 kilograms. What is the approximate weight in pounds?

**Example 6** Complete: 48.8 c  $\approx$  ■ mL

Use the relationship 1 c  $\approx$  236.59 mL.

$$1 \text{ c} \approx 236.59 \text{ mL}$$

$$48.8 \times 1 \text{ c} \approx 48.8 \times 236.59 \text{ mL}$$

$$48.8 \text{ c} \approx 11,545.592 \text{ mL}$$

So, 48.8 cups is approximately 11,545.59 milliliters.

**6-6 Algebra: Solving Proportions** (pp. 310–315)



7.1.9,  
7.2.7

Solve each proportion.

32.  $\frac{x}{10} = \frac{3}{5}$       33.  $\frac{4}{9} = \frac{24}{m}$

34.  $\frac{2}{t} = \frac{8}{50}$       35.  $\frac{15}{w} = \frac{35}{21}$

36.  $\frac{12}{8} = \frac{a}{6}$       37.  $\frac{7}{18} = \frac{d}{6}$

38. **WEIGHT** If 3 televisions weigh 240.6 pounds, how much do 9 of the same televisions weigh?

**Example 7** Solve  $\frac{6}{9} = \frac{n}{12}$ .

$$\frac{6}{9} = \frac{n}{12} \quad \text{Write the proportion.}$$

$$6 \cdot 12 = 9 \cdot n \quad \text{Find the cross products.}$$

$$72 = 9n \quad \text{Multiply.}$$

$$\frac{72}{9} = \frac{9n}{9} \quad \text{Divide each side by 9.}$$

$$8 = n \quad \text{Simplify.}$$



## 6-7

## PSI: Draw a Diagram (pp. 318–319)

P.1.3,  
P.5.1

Solve each problem by drawing a diagram.

39. **PAINTING** Marian is painting a fence that is 72 feet long. She has already painted  $\frac{5}{8}$  of the fence. How many feet of fence does she have left to paint?
40. **COOKIES** A cookie jar contains three types of cookies: oatmeal, chocolate chip, and sugar. 60 percent are chocolate chip. Half of the remaining cookies are oatmeal. If there are 9 oatmeal cookies, how many cookies are in the jar?

**Example 8** Ramiro has filled  $\frac{1}{3}$  or 50 gallons of his fish tank. Find the total capacity of the fish tank.

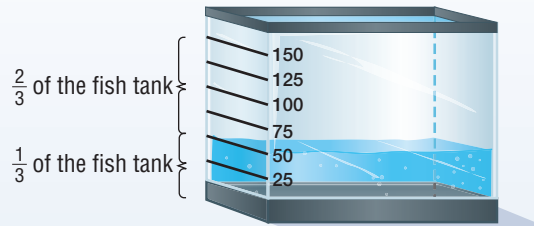

If  $\frac{1}{3}$  of the fish tank is 50 gallons, then  $\frac{2}{3}$  of the fish tank is 100 gallons. So, the missing two thirds must be 100 gallons. The total capacity of the fish tank is  $50 + 100$ , or 150 gallons.

## 6-8

## Scale Drawings (pp. 320–326)



7.3.5

41. **MAPS** Washington, D.C, and Baltimore, Maryland, are 2 inches apart on a map. If the scale is  $\frac{1}{2}$  inch : 6 miles, what is the actual distance between the cities?
42. **MODELS** A Boeing 747 jet is 70.5 meters long and has a wingspan of 60 meters. A model of the 747 has a wingspan of 80 centimeters. What is the length of the model?

**Example 9** On a map, the distance between two cities is 10.9 centimeters. If the scale is 1 centimeter = 250 kilometers, what is the actual distance?

$$\begin{array}{ccc} \text{Scale} & & \text{Distance} \\ \text{map} \rightarrow \frac{1 \text{ cm}}{250 \text{ km}} = \frac{10.9 \text{ cm}}{n \text{ km}} \leftarrow \text{map} \\ \text{actual} \rightarrow & & \leftarrow \text{actual} \\ 1 \cdot n = 250 \cdot 10.9 \\ n = 2,725 \end{array}$$

The actual distance is 2,725 kilometers.

## 6-9

## Fractions, Decimals, and Percents (pp. 328–332)



7.1.6

Write each percent as a fraction in simplest form.

43. 27.5%      44. 5.40%      45.  $45\frac{1}{4}\%$
46. **COINS** A quarter is made of  $\frac{1}{12}$  nickel, and the rest is copper. Write the portion of a quarter that is copper as a percent. Round to the nearest hundredth if necessary.

**Example 10** Write 82.5% as a fraction in simplest form.

$$\begin{array}{l} 82.5\% = \frac{82.5}{100} \\ = \frac{825}{1,000} \\ = \frac{33}{40} \end{array}$$

Write a fraction with a denominator of 100.  
Multiply 82.5 and 100 by 10 to eliminate the decimal.  
Simplify.

**LAWN CARE** For Exercises 1 and 2, use the following information to write each ratio as a fraction in simplest form.

A bag of fertilizer nutrients contains 18 pounds of nitrogen, 6 pounds of phosphorus, and 12 pounds of potassium.

- nitrogen : potassium
- phosphorus : nitrogen

Find each unit rate. Round to the nearest hundredth if necessary.

- 24 greeting cards for \$4.80
- 330 miles on 15 gallons of gasoline

5. **MULTIPLE CHOICE** The population of bacteria in 4 different-sized lab dishes are given. Which dish has the lowest density of bacteria or bacteria per square inch?

Dish	Bacteria	Dish Area
1	100	205 sq in.
2	50	125 sq in.
3	35	75 sq in.
4	180	300 sq in.

- A Dish 1                      C Dish 3  
B Dish 2                      D Dish 4

6. The graph shows the relationship between time and water level of a pool. Find the rate of change.

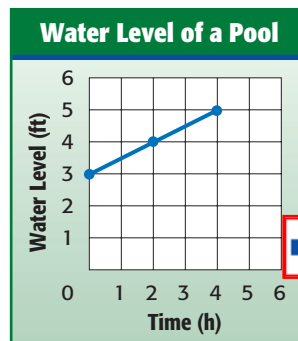

**MEASUREMENT** Complete. Round to the nearest tenth if necessary.

- $7.62 \text{ yd} \approx \square \text{ m}$
- $50.8 \text{ lb} \approx \square \text{ kg}$
- $3,600 \text{ mL} \approx \square \text{ qt}$
- $19.25 \text{ m} \approx \square \text{ ft}$

**ALGEBRA** Solve each proportion.

11.  $\frac{2}{3} = \frac{x}{42}$                       12.  $\frac{t}{21} = \frac{15}{14}$

13. **NUTRITION** If an 8-ounce glass of orange juice has 72 milligrams of vitamin C, how much vitamin C is in a 7-ounce glass?

14. **MAPS** The table shows the key for a map. Graph the data. Then find the slope of the line.

Distance on Map (cm)	1	2	3	4
Actual Distance (km)	20	40	60	80

**BLUEPRINTS** For Exercises 15 and 16, use the following blueprint of a room.

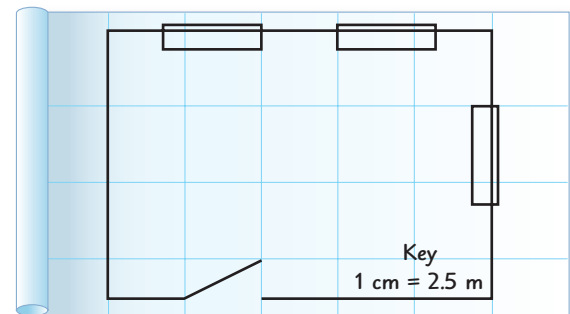

- Use a centimeter ruler to find the length of the wall with 2 windows.
- How wide would a 1.4-meter-wide dresser appear on this drawing?

Write each fraction as a percent. Round to the nearest hundredth if necessary.

17.  $\frac{5}{8}$                       18.  $\frac{7}{15}$

19. **GUM** A company test-marketed 7 new flavors of gum last year. Only 2 of these received favorable ratings. Which represents the percent of flavors that did *not* receive favorable ratings?

20. **STOCKS** A company's stock increased 0.83% last month. Write 0.83% as a decimal.

**PART 1 Multiple Choice**

Read each question. Then fill in the correct answer on the answer sheet provided by your teacher or on a sheet of paper.

- Francesca typed 496 words in 8 minutes. Which of the following is a correct understanding of this rate?
  - On average, it takes 62 minutes for Francesca to type one word.
  - On average, Francesca can type 62 words in 8 minutes.
  - On average, Francesca can type 62 words in one minute.
  - On average, Francesca can type 8 words in one minute.
- The table shows the prices of 3 different boxes of cereal. Which box of cereal has the highest price per ounce?

Cereal Box Size (ounces)	Price (\$)
48	5.45
32	3.95
20	3.10

- The 20-ounce box
  - The 32-ounce box
  - The 48-ounce box
  - All three boxes have the same price per ounce.
- A bakery sells 6 bagels for a total of \$2.99 and 4 muffins for a total of \$3.29. If you bought 4 dozen bagels and 16 muffins, what is the total cost of the bagels and muffins, not including tax?
    - \$64.60
    - \$37.08
    - \$31.10
    - \$26.50

- Mrs. Black is making 2 pasta salads for a picnic. The first pasta salad requires  $4\frac{2}{3}$  cups of pasta, and the second pasta salad requires  $\frac{1}{3}$  cup more than the first. Which of the following equations can be used to find  $n$ , the number of cups of pasta needed for the second recipe?

F  $n = 4\frac{2}{3} \div \frac{1}{3}$

G  $n = 4\frac{2}{3} + \frac{1}{3}$

H  $n = 4\frac{2}{3} - \frac{1}{3}$

J  $n = 4\frac{2}{3} \times \frac{1}{3}$

- Simplify the expression below.

$$8 + 3(15 - 5) - 3^2$$

A 101

C 39

B 44

D 29

- A shoe store had to increase prices. The table shows the regular price  $r$  and the new price  $n$  of several shoes. Which of the following formulas can be used to calculate the new price?

Shoe	Regular Price ( $r$ )	New Price ( $n$ )
A	\$25.00	\$27.80
B	\$30.00	\$32.80
C	\$35.00	\$37.80
D	\$40.00	\$42.80

F  $n = r - 2.80$

H  $n = r \times 0.1$

G  $n = r + 2.80$

J  $n = r \div 0.1$

- Annika can run 2 miles in 15 minutes. At this rate, about how long will it take her to run  $3\frac{1}{2}$  miles?

A 26 minutes

C 36 minutes

B 32 minutes

D 45 minutes



8. A building is 55 meters tall. About how tall is the building in feet (ft) and inches (in.)? (1 meter  $\approx$  39 inches)

F 179 ft 0 in.

G 178 ft 9 in.

H 178 ft 8 in.

J 178 ft 6 in.

9. You can drive your car 21.75 miles with one gallon of gasoline. How many miles can you drive with 13.2 gallons of gasoline?

A 13.2

B 21.75

C 150.2

D 287.1

10. The table shows the number of yards of material Leah used each day last week. What was the total number of yards Leah used last week?

Day	Material (yd)
Monday	2.3
Tuesday	$1\frac{3}{4}$
Wednesday	2.8
Thursday	3.1
Friday	$3\frac{1}{4}$
Saturday	1.7
Sunday	$4\frac{1}{2}$

F 19.4 yd

G 17 yd

H 16.5 yd

J 16 yd

**PART 2** Short Response/Grid In

Record your answers on the answer sheet provided by your teacher or on a sheet of paper.

11. Some employees work 40 hours a week. If there are 168 hours in one week, about what part of the week do they work?

12. During a visit to his favorite bookstore, Kevin bought 3 hardback books priced at \$14.99 each and 4 paperbacks priced at \$7.99 each. Find the total of Kevin's purchase, in dollars, before tax is included.

**PART 3** Extended Response

Record your answers on the answer sheet provided by your teacher or on a sheet of paper. Show your work.

13 Pistachios cost \$3.99 a pound at the local health food store.

a. Set up a proportion to find the cost of 3 pounds.

b. Solve the proportion. How much do 3 pounds of pistachios cost?

c. If the pistachios are on sale for \$3.09 a pound, how much money will you save if you buy 3 pounds of pistachios?

**TEST-TAKING TIP**

**Question 13** When a question involves information from a previous part of a question, make sure to check that information before you move on.

**NEED EXTRA HELP?**

If You Missed Question...

Go to Lesson...

**IN Academic Standards**

1	2	3	4	5	6	7	8	9	10	11	12	13
6-2	6-2	1-1	5-2	1-4	1-10	6-2	6-8	6-6	5-2	6-9	6-7	6-2
7.1.9	7.1.9	7.2.1	6.1.6	7.2.3	7.2.1	7.1.9	7.3.5	7.1.9	6.1.6	7.1.6	P.1.3	7.1.9