

Guide to Using the 5-Minute Check Transparencies with Standardized Test Practice

The first transparency in each chapter is an assessment of skills presented in the previous chapter. The other transparencies in the chapter assess the previous lesson's concepts. Each transparency ends with a standardized test practice question that typifies those students will encounter in the Student Edition and in national testing formats.

How to Use These transparencies can be used as warm-up activities at the beginning of the class period, which enables you to check attendance, pass out papers, or perform other clerical tasks. They can also be used as a quiz or end-of-lesson check to monitor students' understanding of the previous day's concepts.

Glencoe/McGraw-Hill



A Division of The McGraw-Hill Companies

Copyright © by the McGraw-Hill Companies, Inc. All rights reserved.
Printed in the United States of America. Except as permitted under the United States Copyrights Act, no part of this publication may be reproduced or distributed in any form or by any means, or stored in a database or retrieval system, without prior written permission of the publisher.

Send all inquiries to:
Glencoe/McGraw-Hill
8787 Orion Place
Columbus, OH 43240

ISBN: 0-07-827781-7

Pre-Algebra 5-Minute Check Transparencies

1 2 3 4 5 6 7 8 9 10 080 11 10 09 08 07 06 05 04 03 02



5-Minute Check

Transparency 1-1

Find the value of each expression.

1. $1.8 + 0.6$

2. $85.24 + 12.8$

3. $114 - 2.9$

4. 8×47

5. $72 \div 4$

6. **Standardized Test Practice** The sales figures for a business for the months in the first quarter are shown in the table. What were the total sales for the first quarter?

Month	Sales
January	\$12,000
February	\$15,000
March	\$10,000

ANSWERS

1. 2.4

2. 98.04

3. 111.1

4. 376

5. 18

6. \$37,000



5-Minute Check

(over Lesson 1-1)

Transparency 1-2

Find the next term in each list.

1. 4, 10, 16, 22, 28, ...
2. 8, 13, 18, 23, 28, ...

Use the four-step problem-solving plan to solve.

3. Ken uses $\frac{1}{2}$ cup of cat food each day for his cat. If there are $10\frac{1}{2}$ cups left in the bag, how long will the cat food last?
4. Using six coins, how can you make change for 95 cents that will not make change for a quarter?
5. **Standardized Test Practice** Ron plans to add 3 books to his science fiction collection every month. If he has 18 science fiction books now, how many will he have in one year?
 (A) 36 (B) 21 (C) 54 (D) 72

ANSWERS

1. 34
2. 33
3. 21 days
4. 3 quarters, 2 nickels, 1 dime
5. C



5-Minute Check

(over Lesson 1-2)

Transparency 1-3

Find the value of each expression.

1. $54 - 42 \div 7$

2. $80 + 6(11)$

3. $\frac{37 + 38}{30 - 5}$

Write a numerical expression for each verbal phrase.

4. thirteen more than eight

5. thirty-six divided by two

6. **Standardized Test Practice** Which expression does *not* have a value of 24?

(A) $8 + 4 \times 2$

(B) $10 \times 4 - 8 \times 2$

(C) $\frac{8 \times 6}{6 - 4}$

(D) $27 \div 9 \times (14 - 6)$

ANSWERS

1. 48

2. 146

3. 3

4. $8 + 13$

5. $36 \div 2$

6. A



5-Minute Check

(over Lesson 1-3)

Transparency 1-4

Evaluate each expression if $a = 4$, $b = 2$, and $c = 3$.

1. $c + 8 - a$

2. $\frac{ac}{2}$

3. $7a - (2c + b)$

Translate each phrase into an algebraic expression.

4. three feet shorter than the height of the building

5. eight more than three times a number

6. **Standardized Test Practice** Which expression represents *three less than four times a number*?

(A) $3 - 4n$

(B) $4n - 3$

(C) $4(n - 3)$

(D) $3n - 4$

ANSWERS

1. 7

2. 6

3. 20

4. $b - 3$

5. $3n + 8$

6. B



5-Minute Check

(over Lesson 1-4)

Transparency 1-5

Name the property shown by each statement.

1. $(4b)c = 4(bc)$
2. $4y + 0 = 4y$

Find each sum or product mentally.

3. $18 + 13 + 2 + 7$
4. $6 \cdot 7 \cdot 5$
5. Simplify $3 \cdot (y \cdot 9)$.
6. **Standardized Test Practice** Rewrite $(3 + n) + 7$ using the Associative Property.

<input type="radio"/> A	$(n + 3) + 7$	<input type="radio"/> B	$(3 + 7) + n$
<input type="radio"/> C	$7 + (3 + n)$	<input type="radio"/> D	$3 + (n + 7)$

ANSWERS

1. Associative Property of Multiplication
2. Additive Identity
3. 40
4. 210
5. $27y$
6. D



5-Minute Check

(over Lesson 1-5)

Transparency 1-6

Find the solution of each equation from the list given.

1. $5 - x = 2$; 3, 5, 7

2. $7n = 42$; 6, 7, 8

3. $\frac{85}{b} = 5$; 15, 17, 19

Solve each equation mentally.

4. $25 = 5x$

5. $19 - w = 5$

6. **Standardized Test Practice** Which equation represents *two less than three times a number is seven*?

(A) $2 - 3n = 7$

(B) $2 - 7 = 3n$

(C) $3n - 7 = 2$

(D) $3n - 2 = 7$

ANSWERS

1. 3

2. 6

3. 17

4. 5

5. 14

6. D



5-Minute Check

(over Lesson 1-6)

Transparency 1-7

Refer to the graph for Questions 1–5.

Name the point which corresponds to the ordered pair.

1. $(2, 5)$ 2. $(4, 3)$

Write the ordered pair that names each point.

3. Q 4. T

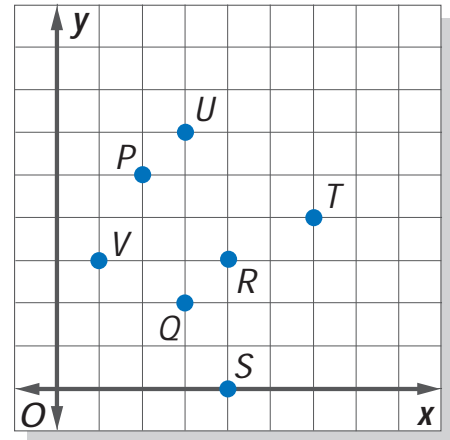

5. Determine the domain and range of the relation.

6. **Standardized Test Practice**

What point lies on both the x-axis and the y-axis?

- (A) $(1, 1)$ (B) $(0, 1)$
(C) $(0, 0)$ (D) $(1, 0)$

ANSWERS

1. P
2. R
3. $(3, 2)$
4. $(6, 4)$
5. domain = $\{1, 2, 3, 4, 6\}$; range = $\{0, 2, 3, 4, 5, 6\}$
6. C



5-Minute Check

(over Chapter 1)

Transparency 2-1

Find the value of each expression.

1. $48 \div 4 - 2 \cdot 3$

2. $3(1 + 5) - 4 \cdot 2$

Evaluate each expression if $a = 6$, $b = 3$, and $c = 5$.

3. $5b + 2c - 1$

4. $a(c - b)$

5. Find the next term in the list 112, 99, 86, 73, 60, ...

6. **Standardized Test Practice** Which sentence does the equation $n - 5 = 10$ represent?

(A) A number is the difference between 10 and 5.

(B) Five more than a number is 10.

(C) Five less than a number is 10.

(D) A number less than 5 is 10.

ANSWERS

1. 6

2. 10

3. 24

4. 12

5. 47

6. C



5-Minute Check

(over Lesson 2-1)

Transparency 2-2

- Write an integer for \$8 withdrawn from a bank account. Then graph on a number line.
- Replace the \bullet in $-9 \bullet -8$ with $<$, $>$, or $=$ to make the sentence true.
- Order the integers $\{-2, 4, -1, 2, -8\}$ from least to greatest.
- Evaluate $-|17|$.
- Evaluate $|-8| + |b| + a$ if $a = 0$ and $b = 12$.
- Standardized Test Practice** The low temperatures for five days in February are shown in the table.

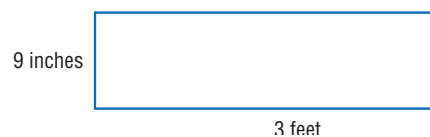

What is the order of these temperatures from greatest to least?

- | | |
|--|--|
| (A) $0^\circ, -2^\circ, -3^\circ, -4^\circ, 5^\circ$ | (B) $5^\circ, 0^\circ, -4^\circ, -3^\circ, -2^\circ$ |
| (C) $-4^\circ, -3^\circ, -2^\circ, 0^\circ, 5^\circ$ | (D) $5^\circ, 0^\circ, -2^\circ, -3^\circ, -4^\circ$ |

ANSWERS

1. -8 ;



2. $<$

3. $\{-8, -2, -1, 2, 4\}$

4. -17

5. 20

6. D



5-Minute Check

(over Lesson 2-2)

Transparency 2-3

Find each sum.

1. $-4 + (-3)$

2. $2 + (-6)$

3. $-14 + 20$

4. $-1 + 4 + (-12)$

5. $10 + 8 + (-8)$

6. **Standardized Test Practice** Holly recorded the difference between morning and evening temperatures each day last week in a table.

Difference in Temperature							
Day	Sun.	Mon.	Tues.	Wed.	Thurs.	Fri.	Sat.
Change	6	5	4	3	4	1	4

Which day had the greatest change in temperature?

- (A) Sun. (B) Mon. (C) Fri. (D) Sat.

ANSWERS

1. -7

2. -4

3. 6

4. -9

5. 10

6. A



5-Minute Check

(over Lesson 2-3)

Transparency 2-4

Find each difference.

1. $9 - (-1)$

2. $-3 - (-21)$

3. $-8 - (3)$

4. $12 - 21$

5. Evaluate the expression $a - b$ if $a = -7$ and $b = 9$.

6. **Standardized Test Practice** When a number is subtracted from 17 the result is 20. What is the number?

(A) 3

(B) 37

(C) -3

(D) -37

ANSWERS

1. 10

2. 18

3. -11

4. -9

5. -16

6. C



5-Minute Check

(over Lesson 2-4)

Transparency 2-5

Find each product.

1. $-9 \cdot 8$

2. $-3(-13)$

3. $-5(-3)(4)$

4. Simplify $-2 \cdot (-3y)$.

5. Evaluate $-7ab$ if $a = -1$ and $b = 4$.

6. **Standardized Test Practice** What is the next number in the pattern $-3, 6, -12, 24, \dots$?

(A) 48

(B) -48

(C) 36

(D) -36

ANSWERS

1. -72

2. 39

3. 60

4. $6y$

5. 28

6. B



5-Minute Check

(over Lesson 2-5)

Transparency 2-6

Find each quotient.

1. $-45 \div (-5)$

2. $72 \div (-12)$

3. $\frac{-90}{6}$

Evaluate each expression.

4. $\frac{a}{-8}$ if $a = -96$

5. $\frac{x}{y}$ if $x = -65$ and $y = -5$

6. **Standardized Test Practice** What is the average (mean) of -7 , 6 , -11 , 9 , and -2 ?

(A) -1

(B) 1

(C) -5

(D) 7

ANSWERS

1. 9

2. -6

3. -15

4. 12

5. 13

6. A



5-Minute Check

(over Chapter 2)

Transparency 3-1

Evaluate each expression if $a = -8$, $b = 2$, and $c = -5$.

1. $|a|$

2. $b + c$

3. $-3a$

4. $c - a$

5. $\frac{a}{b}$

6. **Standardized Test Practice** What is the average (mean) of -13 , 16 , -19 , and -4 ?

(A) -13

(B) 13

(C) -5

(D) 5

ANSWERS

1. 8

2. -3

3. 24

4. 3

5. -4

6. C



5-Minute Check

(over Lesson 3-1)

Transparency 3-2

Use the Distributive Property to write each expression as an equivalent expression. Then evaluate it.

1. $(4 + 5)3$

2. $6(7 - 1)$

Use the Distributive Property to write each expression as an equivalent algebraic expression.

3. $3(x + 8)$

4. $(n - 2)9$

5. $-2(a + 5)$

6. **Standardized Test Practice** Which equation is always true?

(A) $-4y - 12 = -4(y - 3)$

(B) $-4y - 12 = -4(y + 3)$

(C) $-4(y - 12) = -4y - 12$

(D) $(y - 3)4 = -4y - 12$

ANSWERS

1. $4 \cdot 3 + 5 \cdot 3; 27$

4. $9n - 18$

2. $6 \cdot 7 + 6 \cdot (-1); 36$

5. $-2a - 10$

3. $3x + 24$

6. B



5-Minute Check

(over Lesson 3-2)

Transparency 3-3

1. Identify the terms, like terms, coefficients, and constants in the expression $4q + 5p - 9 - p + 8q$.

Simplify each expression.

2. $4m + 6m + 3$

3. $24a - a + 16$

4. $9(r + 7) - 12r$

5. $6(x - 2) + 8x$

6. **Standardized Test Practice** Which expression is *not* equivalent to $-2n - 8$?

(A) $6 - 2(n + 7)$

(B) $-2(n + 5) + 2$

(C) $-6n - 8 + 8n$

(D) $4n - 3 - 6n - 5$

ANSWERS

1. terms: $4q, 5p, -9, -p, 8q$
like terms: $4q, 8q; 5p, -p$
coefficients: $4, 5, -1, 8$
constants: -9

2. $10m + 3$

3. $23a + 16$

4. $-3r + 63$

5. $14x - 12$

6. C



5-Minute Check

(over Lesson 3-3)

Transparency 3-4

Solve each equation. Check your solution.

1. $x - 3 = -6$

2. $y + 9 = 7$

3. $23 = m - 6$

Write and solve an equation to find each number.

4. The difference of a number and 7 is 17.

5. The sum of -11 and a number is -20 .

6. **Standardized Test Practice** If $y + 5 = -3$, what is the value of $-3y - 15$?

(A) -9

(B) 9

(C) -21

(D) -39

ANSWERS

1. -3

2. -2

3. 29

4. $n - 7 = 17$; 24

5. $-11 + n = -20$; -9

6. B



5-Minute Check

(over Lesson 3-4)

Transparency 3-5

Solve each equation.

1. $\frac{x}{3} = -6$

2. $-3x = -21$

3. $\frac{x}{-2} = -16$

Write and solve an equation for each sentence.

4. The quotient of a number and 7 is -1

5. The product of a number and -4 is -32 .

6. **Standardized Test Practice** If a number divided by -7 equals -1 , what is the number?

ANSWERS

1. -18

2. 7

3. 32

4. $\frac{x}{7} = -1$; -7

5. $-4x = -32$; 8

6. 7



5-Minute Check

(over Lesson 3-5)

Transparency 3-6

Solve each equation.

1. $3m + 5 = 17$

2. $-6 = 2a - 4$

3. $\frac{x}{2} + 5 = 13$

4. $-5x + 4 = 29$

5. $\frac{r}{5} - 8 = 1$

6. **Standardized Test Practice** Which equation does *not* have a solution of -9 ?

(A) $6x + 29 = -25$

(B) $\frac{x}{3} + 12 = 9$

(C) $-1 = 2x + 17$

(D) $5 + \frac{x}{-3} = 2$

ANSWERS

1. 4

2. -1

3. 16

4. -5

5. 45

6. D



5-Minute Check

(over Lesson 3-6)

Transparency 3-7

Translate each sentence into an equation. Then find each number.

1. Seven more than three times a number is 34.
2. Nine less than six times a number is 57.
3. The quotient of a number and -3 , less 5, is -7 .

Solve each problem by writing and solving an equation.

4. Sam sold a car for \$200 more than half the original price. If he sold the car for \$6540, what was the original price?
5. Erik scored 12 points more than Juanita on a science test. Together they scored 170 points. What was Eric's score on the test?
6. **Standardized Test Practice** Jake's age is 5 years less than twice his brother's age. His brother is 10 years old. How old is Jake?

(A) 5 (B) 10 (C) 15 (D) 20

ANSWERS

1. $7 + 3n = 34$; 9
2. $6n - 9 = 57$; 11
3. $\frac{n}{-3} - 5 = -7$; 6
4. $6540 = 200 + \frac{n}{2}$; \$12,680
5. $2n + 12 = 170$; 91
6. C



5-Minute Check

(over Chapter 3)

Transparency 4-1

Solve. Check each solution.

1. $x - 3 = 9$

2. $2x = -16$

3. $-12 = \frac{x}{-6}$

4. $3x - 2 = 13$

5. Janet's age is 3 years less than three times her cousin's age. The sum of their ages is 29. What is Janet's age?

6. **Standardized Test Practice** The total cost of a shirt and pair of jeans is \$72. The jeans cost twice as much as the shirt. Which equation could be used to find the cost of the shirt s ?

(A) $2s = 72$

(B) $s + 2s = 72$

(C) $2s - s = 72$

(D) $s + 3 = 72$

ANSWERS

1. 12

2. -8

3. 72

4. 5

5. 21 years

6. B



5-Minute Check

(over Lesson 4-1)

Transparency 4-2

Use divisibility rules to determine whether each number is divisible by 2, 3, 5, 6, or 10.

1. 48
2. 155
3. 1230

List all the factors of each number.

4. 116
5. 110

6. **Standardized Test Practice** Which of the following expressions is a monomial?

(A) $1 + n$

(B) $-5xy$

(C) $7(n - 4)$

(D) $7x - 7$

ANSWERS

1. 2, 3, 6
2. 5
3. 2, 3, 5, 6, 10
4. 1, 2, 4, 29, 58, 116
5. 1, 2, 5, 10, 11, 22, 55, 110
6. B



5-Minute Check

(over Lesson 4-2)

Transparency 4-3

Write each expression using exponents.

1. $(-5)(-5)(-5)$
2. $m \cdot m \cdot m \cdot m \cdot m \cdot m$
3. $4 \cdot a \cdot a \cdot (b + 1)(b + 1)$

Evaluate each expression if $a = -3$ and $b = -1$.

4. $a^0 + 13$
5. a^2b^3
6. **Standardized Test Practice** Which of these is the expanded form of 1706?
 - (A) $(1 \times 10^3) + (7 \times 10^2) + (6 \times 10^1) + (0 \times 10^0)$
 - (B) $(1 \times 10^3) + (7 \times 10^2) + (0 \times 10^1) + (6 \times 10^0)$
 - (C) $(1 \times 10^4) + (7 \times 10^3) + (0 \times 10^2) + (6 \times 10^1)$
 - (D) $(1 \times 10^4) + (0 \times 10^3) + (7 \times 10^2) + (6 \times 10^1)$

ANSWERS

1. $(-5)^3$
2. m^6
3. $4a^2(b + 1)^2$
4. 14
5. -9
6. B



5-Minute Check

(over Lesson 4-3)

Transparency 4-4

Determine whether each number is prime or composite.

1. 51
2. 37

Write the prime factorization of each number.
Use exponents for repeated factors.

3. 75
4. 108
5. Factor $15x^2$.
6. **Standardized Test Practice** Molly wants to express 243 as a power of 3. What exponent should she use?

ANSWERS

1. composite
2. prime
3. $3 \cdot 5^2$
4. $2^2 \cdot 3^3$
5. $3 \cdot 5 \cdot x \cdot x$
6. 5



5-Minute Check

(over Lesson 4-4)

Transparency 4-5

Find the GCF of each set of numbers or monomials.

1. 22, 55
2. 15, 18, 31
3. $27xy$, $45y^2$

Factor each expression.

4. $12 + 6a$
5. $18x + 30y$

6. **Standardized Test Practice**

Find the GCF of $35x^2y$ and $84xy^3$.

- | | |
|-----------------------------------|-------------------------------|
| <input type="radio"/> A 7 | <input type="radio"/> B $7xy$ |
| <input type="radio"/> C $7x^2y^2$ | <input type="radio"/> D $6xy$ |

ANSWERS

1. 11
2. 1
3. $9y$
4. $6(2 + a)$
5. $6(3x + 5y)$
6. B



5-Minute Check

(over Lesson 4-5)

Transparency 4-6

Write each fraction in simplest form. If the fraction is already in simplest form, write *simplified*.

1. $\frac{8}{24}$

2. $\frac{16}{25}$

3. $\frac{42}{56}$

4. $\frac{15x}{18x}$

5. $\frac{6a^4}{21a}$

6. **Standardized Test Practice** Which fraction is $\frac{17abc^4}{a^3b}$ written in simplest form?

(A) $17a^4c^4$

(B) $\frac{17a^2}{c^4}$

(C) $\frac{17bc^4}{a^2}$

(D) $\frac{17c^4}{a^2}$

ANSWERS

1. $\frac{1}{3}$

4. $\frac{5}{6}$

2. simplified

5. $\frac{2a^3}{7}$

3. $\frac{3}{4}$

6. D



5-Minute Check

(over Lesson 4-6)

Transparency 4-7

Find each product or quotient. Express using exponents.

1. $10^8 \cdot 10^4$

2. $a^5 \cdot a^5$

3. $10^8 \div 10^4$

4. $\frac{x^9}{x^3}$

5. $4y \cdot 5y^4$

6. **Standardized Test Practice** Find the product of n^6 and n^2 .

(A) n^8

(B) n^{12}

(C) n^3

(D) n^4

ANSWERS

1. 10^{12}

2. a^{10}

3. 10^4

4. x^6

5. $20y^5$

6. A



5-Minute Check

(over Lesson 4-7)

Transparency 4-8

Write each expression using a positive exponent.

1. 2^{-3}
2. a^{-1}
3. $(-5)^{-4}$

Write each fraction as an expression using a negative exponent other than -1 .

4. $\frac{1}{4^5}$
5. $\frac{1}{49}$
6. **Standardized Test Practice** Evaluate n^{-4} if $n = -2$.

(A) -8	(B) $\frac{1}{8}$
(C) $\frac{1}{16}$	(D) -16

ANSWERS

1. $\frac{1}{2^3}$
2. $\frac{1}{a}$
3. $\frac{1}{(-5)^4}$
4. 4^{-5}
5. 7^{-2}
6. C



5-Minute Check

(over Chapter 4)

Transparency 5-1

Find the GCF of each set of numbers or monomials.

1. 12, 30
2. $9a^3$, $15ab$

Find each product or quotient. Express using positive exponents.

3. $3^5 \cdot 3^4$
4. $(5a^2)(-7a^3)$
5. $\frac{x^2}{x^6}$
6. **Standardized Test Practice** The population of the world is estimated to be 6,148,000,000 people. What is 6,148,000,000 expressed in scientific notation?

(A) 6148×10^6	(B) 6148×10^9
(C) 6.148×10^6	(D) 6.148×10^9

ANSWERS

1. 6
2. $3a$
3. 3^9
4. $-35a^5$
5. $\frac{1}{x^4}$
6. D



5-Minute Check

(over Lesson 5-1)

Transparency 5-2

Write each fraction or mixed number as a decimal.
Use a bar to show a repeating decimal.

1. $-\frac{9}{20}$

2. $2\frac{1}{8}$

3. $\frac{7}{9}$

Replace each \bullet with $<$, $>$, or $=$ to make a true sentence.

4. $0.7 \bullet \frac{2}{3}$

5. $2\frac{5}{6} \bullet 2.\bar{8}$

6. **Standardized Test Practice** Which number is less than $5\frac{1}{4}$?

(A) $5\frac{1}{3}$

(B) $5\frac{1}{2}$

(C) $5.\bar{2}$

(D) $5.\bar{4}$

ANSWERS

1. -0.45

2. 2.125

3. $0.\bar{7}$

4. $>$

5. $<$

6. C



5-Minute Check

(over Lesson 5-2)

Transparency 5-3

Write each number as an improper fraction.

1. $-2\frac{3}{4}$
2. 29

Write each decimal as a fraction or mixed number in simplest form.

3. 0.6
4. 3.25
5. $0.\overline{3}$

6. **Standardized Test Practice** Which is *not* a rational number?

(A) $\frac{2}{7}$

(B) π

(C) 0.43

(D) 2.3333...

ANSWERS

1. $-\frac{11}{4}$

2. $\frac{29}{1}$

3. $\frac{3}{5}$

4. $3\frac{1}{4}$

5. $\frac{1}{3}$

6. B



5-Minute Check

(over Lesson 5-3)

Transparency 5-4

Find each product. Write in simplest form.

1. $\frac{5}{9} \cdot \frac{2}{3}$

2. $\frac{3}{8} \cdot \frac{16}{21}$

3. $\frac{9}{10} \cdot (-5)$

4. $\frac{2x}{3} \cdot \frac{4}{x}$

5. $\frac{5b}{a} \cdot \frac{6a^4}{c}$

6. **Standardized Test Practice** The product of $\frac{7}{8}$ and 2 is a number

- (A) less than 1.
- (B) between 1 and 2.
- (C) between 2 and 3.
- (D) greater than 3.

ANSWERS

1. $\frac{10}{27}$

4. $2\frac{2}{3}$

2. $\frac{2}{7}$

5. $\frac{30ba^3}{c}$

3. $-4\frac{1}{2}$

6. B



5-Minute Check

(over Lesson 5-4)

Transparency 5-5

1. Find the multiplicative inverse of $\frac{5}{11}$.

Find each quotient. Write in simplest form.

2. $\frac{1}{3} \div \frac{9}{10}$

3. $-6 \div \frac{3}{8}$

4. $\frac{y}{28} \div \frac{2y}{7}$

5. How many $\frac{1}{2}$ -pound bags of potting soil can be filled from a 12-pound container of potting soil?

6. **Standardized Test Practice** What is $\frac{5}{6}$ divided by $-\left(\frac{5}{6}\right)$?

(A) -1

(B) $\frac{36}{25}$

(C) 1

(D) $-\frac{25}{36}$

ANSWERS

1. $\frac{11}{5}$

2. $\frac{10}{27}$

3. -16

4. $\frac{1}{8}$

5. 24

6. A



5-Minute Check

(over Lesson 5-5)

Transparency 5-6

Find each sum or difference. Write in simplest form.

1. $\frac{4}{5} - \frac{1}{5}$

2. $2\frac{3}{8} + 1\frac{3}{8}$

3. $4\frac{5}{6} - 2\frac{1}{6}$

4. $\frac{a}{12} + \frac{2a}{12}$

5. $\frac{6}{y} - \frac{1}{y}, y \neq 0$

6. **Standardized Test Practice** What is the value of

$2\frac{1}{3} + 5\frac{2}{3} - 3\frac{1}{3}$?

(A) $11\frac{1}{3}$

(B) $4\frac{1}{3}$

(C) $4\frac{2}{3}$

(D) $10\frac{2}{3}$

ANSWERS

1. $\frac{3}{5}$

4. $\frac{a}{4}$

2. $3\frac{3}{4}$

5. $\frac{5}{y}$

3. $2\frac{2}{3}$

6. C



5-Minute Check

(over Lesson 5-6)

Transparency 5-7

Find the least common multiple (LCM) of each set of numbers or monomials.

1. 8, 20
2. 6, 12, 15
3. $9d$, $12d$
4. $6a^2$, $8ab$
5. Replace the ● with $<$, $>$, or $=$ to make a true statement.

$$\frac{12}{19} \bullet \frac{36}{57}$$

6. **Standardized Test Practice** Which of the following size buttons is the smallest?

(A) $\frac{1}{2}$ inch

(B) $\frac{3}{8}$ inch

(C) $\frac{1}{4}$ inch

(D) $\frac{5}{16}$ inch

ANSWERS

1. 40

2. 60

3. $36d$

4. $24a^2b$

5. $=$

6. C



5-Minute Check

(over Lesson 5-7)

Transparency 5-8

Find each sum or difference. Write in simplest form.

1. $\frac{7}{15} + \frac{1}{3}$

2. $\frac{3}{4} - \frac{11}{12}$

3. $6\frac{1}{4} + 3\frac{5}{6}$

4. $1\frac{9}{10} - \frac{2}{5}$

5. A candy shop had $9\frac{3}{4}$ pounds of fancy chocolates, but sold $2\frac{1}{2}$ pounds to a customer. How many pounds of the chocolates were left?

6. **Standardized Test Practice** Choose the best estimate for

$$2\frac{4}{9} + 5\frac{7}{12}$$

(A) 7

(B) 8

(C) 9

(D) 10

ANSWERS

1. $\frac{4}{5}$

2. $-\frac{1}{6}$

3. $10\frac{1}{12}$

4. $1\frac{1}{2}$

5. $7\frac{1}{4}$

6. B



5-Minute Check

(over Lesson 5-8)

Transparency 5-9

Find the mean, median, and mode for each set of data. If necessary, round to the nearest tenth.

- 94, 90, 100, 95, 90
- 52, 66, 44, 23, 44, 52, 44, 51
- 1.5, 2.5, 1.9, 2.7, 1.7, 6.0, 5.4
-

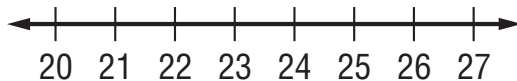

5. **Standardized Test Practice** The amounts of monthly rainfall for a certain county are shown below.

Month	Jan.	Feb.	Mar.	Apr.	May	June
Amount (inches)	1.5	2.0	2.8	3.1	0.5	2.9

If the county has 3.0 inches of rain in July, what will the median of the data set be?

ANSWERS

- mean, 93.8; median, 94; mode, 90
- mean, 47; median, 47.5; mode, 44
- mean, 3.1; median, 2.5; no mode
- mean, 23.3; median, 23.5; modes, 21 and 25
- 2.8 inches



5-Minute Check

(over Lesson 5-9)

Transparency 5-10

Solve each equation. Check your solution.

1. $n + 6.3 = 11.2$

2. $9.4 = w - 9.4$

3. $k - \frac{3}{4} = -\frac{2}{3}$

4. $-0.5a = 20$

5. $\frac{5}{6} = \frac{1}{9}c$

6. **Standardized Test Practice**

What is the length of the rectangular mat shown at the right?

$\frac{5}{8}$ yd

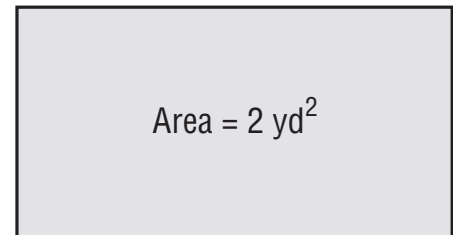

(A) $1\frac{1}{4}$ yd

(B) $\frac{5}{16}$ yd

(C) $3\frac{1}{5}$ yd

(D) $1\frac{3}{8}$ yd

ANSWERS

1. 4.9

2. 18.8

3. $\frac{1}{12}$

4. -40

5. $7\frac{1}{2}$

6. C



5-Minute Check

(over Chapter 5)

Transparency 6-1

1. Write $3\frac{3}{8}$ as a decimal.
2. Write -0.05 as a fraction in simplest form.

Solve each equation.

3. $\frac{2}{3}x = \frac{8}{9}$

4. $n - \frac{3}{4} = 1\frac{1}{2}$

5. In a survey of students, $\frac{13}{25}$ of the girls and $\frac{11}{20}$ of the boys have a pet. Does a greater fraction of girls or boys have a pet?

6. **Standardized Test Practice** Which statement is true about $\{6, 2, 7, 3, 4, 6, 2, 4, 2\}$?

- (A) The mean and the mode are the same number.
- (B) The median and the mode are the same number.
- (C) The mean and the median are the same number.
- (D) The median, the mean, and the mode are different numbers.

ANSWERS

1. 3.375

2. $-\frac{1}{20}$

3. $x = 1\frac{1}{3}$

4. $n = 2\frac{1}{4}$

5. $\frac{13}{25} = 0.52$ and $\frac{11}{20} = 0.55$.

Because $0.55 > 0.52$, a greater fraction of boys has a pet.

6. C



5-Minute Check

(over Lesson 6-1)

Transparency 6-2

Express each ratio as a fraction in simplest form.

1. 10 tulips to 18 daffodils 2. 5 yards to 10 feet

Express each ratio as a unit rate. Round to the nearest tenth, if necessary.

3. 230 miles in 4.5 hours 4. 54 pages in 30 minutes

5. Express the ratio of the width to the length as a fraction in simplest form.

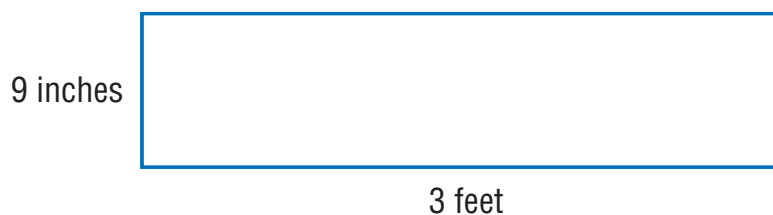

6. **Standardized Test Practice** What is the cost per pound for a 20-ounce box of cereal that sells for \$4.50?

- (A) \$2.25 (B) \$3.60
(C) \$5.63 (D) \$4.50

ANSWERS

1. $\frac{5}{9}$ 4. 1.8 pages/min
2. $\frac{3}{2}$ 5. $\frac{1}{4}$
3. 51.1 mi/h 6. B



5-Minute Check

(over Lesson 6-2)

Transparency 6-3

Solve each proportion.

1. $\frac{x}{9} = \frac{20}{45}$

2. $\frac{14}{3} = \frac{42}{n}$

Write a proportion that could be used to solve for each variable. Then solve.

3. 18 donuts in 3 boxes
30 donuts in b boxes

4. 5 pounds of meat for \$17.45
 p pounds of meat for \$10.47

5. There are approximately 2.54 centimeters in 1 inch. Write a proportion that could be used to find the length, in inches, of a meter stick (100 centimeters). What is the length, in inches, of a meter stick?

6. **Standardized Test Practice** There are 35 red and blue marbles in a bag. The ratio of blue marbles to red marbles is 2 to 5. Which proportion could be used to find the number of red marbles in the bag?

(A) $\frac{2}{5} = \frac{r}{35}$

(B) $\frac{2}{7} = \frac{r}{35}$

(C) $\frac{5}{7} = \frac{r}{35}$

(D) $\frac{5}{35} = \frac{7}{r}$

ANSWERS

1. $x = 4$

4. $\frac{5}{17.45} = \frac{p}{10.47}$; 3

2. $n = 9$

5. $\frac{2.54}{1} = \frac{100}{x}$; 39.37 in.

3. $\frac{18}{3} = \frac{30}{b}$; 5

6. C



5-Minute Check

(over Lesson 6-3)

Transparency 6-4

On a floor plan for a new house, the scale is $\frac{1}{2}$ inch = 2 feet. Find the actual length of each room.

1. Master bedroom: 5 inches
2. Living room: $3\frac{1}{4}$ inches
3. Kitchen: 2.8 inches
4. On a map the distance between two cities is 4.5 inches. The actual distance is 270 miles. What is the scale of the map?
5. A flower garden is 3 feet wide by 8 feet long. What will be the width and length of the garden on a scale drawing if the scale is $\frac{1}{4}$ inch = 1 foot?
6. **Standardized Test Practice** Which scale has a scale factor of $\frac{1}{15}$?
 - (A) 1 in. = 5 ft
 - (B) 6 in. = 10 ft
 - (C) 4 in. = 5 ft
 - (D) 15 in. = 15 ft

ANSWERS

1. 20 feet
2. 13 feet
3. 11.2 feet
4. 1 inch = 60 miles
5. $\frac{3}{4}$ inch wide; 2 inches long
6. C



5-Minute Check

(over Lesson 6-4)

Transparency 6-5

Express each decimal or fraction as a percent.
Round to the nearest tenth percent, if necessary.

1. $\frac{11}{40}$

2. 0.007

Express each percent as a decimal and as a fraction
in simplest form.

3. 32%

4. 6%

5. Choose the greatest number in the set.

$\{38\%, \frac{2}{5}, 0.35, 1 \text{ out of } 3\}$

6. **Standardized Test Practice** Which figure has the greatest part of its area shaded?

(A)

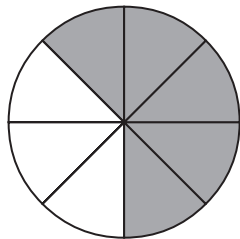

(B)



(C)

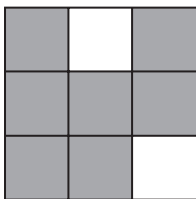

(D)

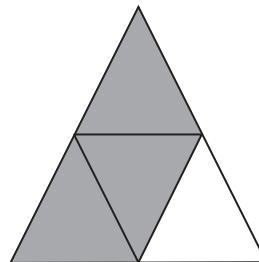

ANSWERS

1. $27\frac{1}{2}\%$

3. 0.32; $\frac{8}{25}$

5. $\frac{2}{5}$

2. 0.7%

4. 0.06; $\frac{3}{50}$

6. B



5-Minute Check

(over Lesson 6-5)

Transparency 6-6

Use the percent proportion to solve each problem.

- 18 is what percent of 75?
- 14 is 40% of what number?
- What is 56% of 125?
- 24.5 is what percent of 98?
- At a bake sale, 63 cookies were sold. This was 75% of the number of cookies baked. How many cookies were baked?
- Standardized Test Practice** Twenty-four of 30 students in a class met their goal in the pizza sale. What percent of the students did not meet their goal in the sale?
 A 80% B 6%
 C 76% D 20%

ANSWERS

- 24%
- 35
- 70
- 25%
- 84 cookies
- D



5-Minute Check

(over Lesson 6-6)

Transparency 6-7

Find the percent of each number mentally.

1. 125% of 80 2. $33\frac{1}{3}\%$ of 90

Estimate. Explain which method you used to estimate.

3. 79% of 40 4. 67% of 120

5. In 1990, the population of a town was about 65,000. By 2000, the population increased to about 180% of the 1990 figure. About how many people lived in the town in 2000?

6. **Standardized Test Practice** A store is having a 25%-off sale on all televisions. About how much will a television that regularly sells for \$359 cost?

- (A) \$90 (B) \$270
(C) \$335 (D) \$288

ANSWERS

1. 100
2. 30
3. Sample answer: 32; fraction method; $\frac{4}{5} \times 40$, or 32
4. Sample answer: 80; fraction method; $\frac{2}{3} \times 120$, or 80
5. 117,000
6. B



5-Minute Check

(over Lesson 6-7)

Transparency 6-8

Solve each problem using the percent equation.

1. 24 is what percent of 80?
2. 39 is 52% of what number?
3. Find 26.3% of 135.
4. What is the annual interest rate if \$2500 is invested for 2 years and \$225 in interest is earned?
5. One season the Miami Dolphins had 10 wins. This was 62.5% of the games the team played. How many games did they play?
6. **Standardized Test Practice** What will be the discount on the price of the mountain bike?

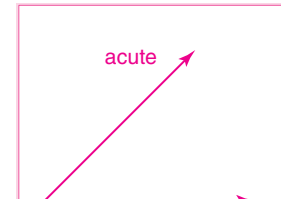

ANSWERS

1. 30%
2. 75
3. 35.505
4. 4.5%
5. 16
6. \$43.35



5-Minute Check

(over Lesson 6-8)

Transparency 6-9

State whether each change is a percent of increase or a percent of decrease. Then find the percent of change. Round to the nearest tenth, if necessary.

1. from \$15 to \$18
2. from 80 lb to 72 lb
3. from 325 ft to 280 ft
4. Myra bought a new car. Her monthly car payment went from \$294 to \$324. Find the percent of change.
5. **Standardized Test Practice** Which represents the percent of change in the total number of students between the two school years?

Number of Students	2001–2002	2002–2003
6th Grade	420	462
7th Grade	432	422
8th Grade	398	416

- (A) 5% (B) 4% (C) 4.5% (D) 10%

ANSWERS

1. percent of increase; 20%
2. percent of decrease; -10%
3. percent of decrease; -13.8%
4. percent of increase of 10.2%
5. B



5-Minute Check

(over Chapter 6)

Transparency 7-1

1. Express *24 inches to 6 feet* in simplest form.
2. Express 0.045 as a percent.
3. Express 65% as a fraction in simplest form.
4. 30 is 40% of what number?
5. A pair of sneakers that normally sells for \$85 is on sale at a 20% discount. What is the sale price of the sneakers?
6. **Standardized Test Practice** What is the annual interest rate if Jim invests \$2400 for 3 years and earns \$450 in interest?

ANSWERS

1. 1 to 3
2. 4.5%
3. $\frac{13}{20}$
4. 75
5. \$68
6. 6.25%



5-Minute Check

(over Lesson 7-1)

Transparency 7-2

Solve each equation.

1. $2x + 15 = 7x$

2. $5a = 3a - 18$

3. $1.3 - 3b = b - 0.3$

4. $4x - 7 = -5x - 25$

5. $7.5 + n = 2.7n - 1$

6. **Standardized Test Practice** What is the solution of $6 - 2a = 2a - 6$?

(A) -1

(B) 0

(C) -3

(D) 3

ANSWERS

1. 3

2. -9

3. 0.4

4. -2

5. 5

6. D



5-Minute Check

(over Lesson 7-2)

Transparency 7-3

Solve each equation.

1. $2(x - 5) = 8$

2. $3(2a - 1) = 42$

3. $6(n - 4) = 3(n + 3)$

4. $5(x - 4) = 2(x - 2.5)$

5. Find the dimensions of the rectangle. The perimeter is 90 meters.

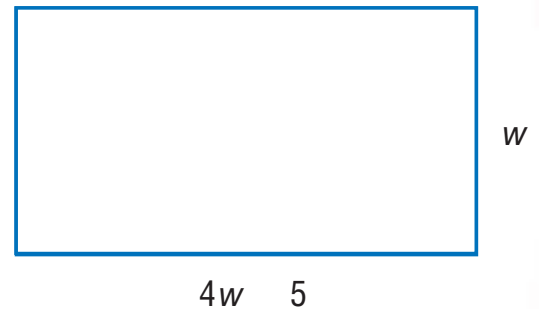

6. **Standardized Test Practice** Which equation has no solution?

(A) $12n - 6 = 2(n + 1)$

(B) $5(n + 4) + 8 = 5n + 20$

(C) $8n - 7 = 5(n - 5)$

(D) $4(2n + 6) = 4(n + 3)$

ANSWERS

1. 9

2. 7.5

3. 11

4. 5

5. $w = 10$ m, $\ell = 35$ m

6. B



5-Minute Check

(over Lesson 7-3)

Transparency 7-4

Write an inequality for each sentence.

1. A number decreased by 7 is at most 9.
2. There are more than 500 students at Candlewood Middle School.

For the given value, state whether each inequality is *true* or *false*.

3. $15 - n < 9, n = 4$ 4. $6a \geq 42, a = 7$

5. Write the inequality for the graph.



6. **Standardized Test Practice** If Mike collects 3 more model planes, he will have at least 10 model planes. Which inequality represents this situation?

- (A) $p + 3 > 10$ (B) $p + 3 < 10$
(C) $p + 3 \geq 10$ (D) $p + 3 \leq 10$

ANSWERS

1. $n - 7 \leq 9$ 4. true
2. $s > 500$ 5. $x > -2$
3. false 6. C



5-Minute Check

(over Lesson 7-4)

Transparency 7-5

Solve each inequality.

1. $k + 5 > -2$

2. $5.7 \leq n - 3$

3. $25 + t \leq 21$

4. $-18 \geq -24\frac{1}{3} + m$

5. $-8 < x - (-4)$

6. **Standardized Test Practice** Tina can spend \$20 at most on 2 birthday presents. If she spends \$9.50 on one present, which inequality represents all the possible amounts p that she can spend on the other present?

(A) $p \leq 9.50$

(B) $p \geq 10.50$

(C) $p \leq 10.50$

(D) $p \geq 9.50$

ANSWERS

1. $k > -7$

2. $n \geq 8.7$

3. $t \leq -4$

4. $m \leq 6\frac{1}{3}$

5. $x > -12$

6. C



5-Minute Check

(over Lesson 7-5)

Transparency 7-6

Solve each inequality.

1. $2x > 22$

2. $\frac{p}{3} \leq -15$

3. $-5b \geq 35$

4. $0.8r < -24$

5. $\frac{x}{-3} \leq -6$

6. **Standardized Test Practice** The product of an integer and -9 is less than -45 . Find the least integer that meets this condition.

ANSWERS

1. $x > 11$

2. $p \leq -45$

3. $b \leq -7$

4. $r < -30$

5. $x \geq 18$

6. 6



5-Minute Check

(over Chapter 7)

Transparency 8-1

Solve each equation.

1. $6x = 2x - 24$

2. $2(4 - 3x) = -4$

3. $3(2x - 3) = 15$

4. Solve $10 - 8x \geq -14 + 4x$. Graph the solution on a number line.

5. The perimeter of a rectangle is 48 inches. The length is 3 inches less than twice the width. What are the dimensions of the rectangle?

6. **Standardized Test Practice** Austin's scores are shown in the table. Which inequality represents the score he must get in the third game to have an average of more than 150?

Game	Score
1	162
2	135
3	

(A) $s > 153$

(B) $s \geq 153$

(C) $s < 153$

(D) $s \leq 153$

ANSWERS

1. -6

2. 2

3. 4

4. $x \leq 2$;

5. $w: 9$ in., $l: 15$ in.

6. A



5-Minute Check

(over Lesson 8-1)

Transparency 8-2

Determine whether each relation is a function.

- $\{(-2, -2), (0, 1), (-2, 3), (4, 5)\}$
- $\{(4, -4), (-4, 4), (5, -5), (-5, 5), (1, 5)\}$

3.

x	y
-1	-2
3	2
0	0
-1	2
-2	4

4.

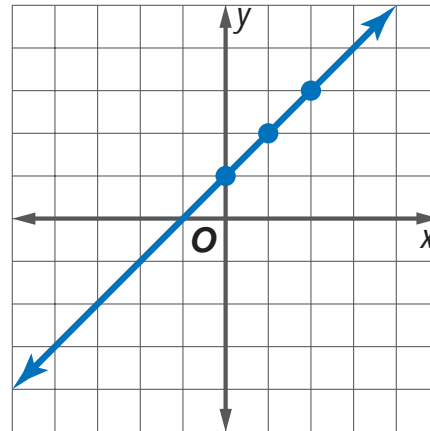

5. **Standardized Test Practice** The relation $\{(3, 5), (2, -3), (1, 0), (-4, 0), (-2, 5)\}$ is *not* a function when which ordered pair is added to the set?

- (A) $(0, -4)$ (B) $(-3, 2)$
(C) $(3, -5)$ (D) $(-1, 0)$

ANSWERS

- no
- yes
- no
- yes
- C



5-Minute Check

(over Lesson 8-2)

Transparency 8-3

1. Copy and complete the table. Use the results to write four solutions of the given equation.

x	$y = 3x - 1$	y	(x, y)
-2	$3(-2) - 1$		
0			
2			
4			

Find two solutions of each equation. Write the solutions as ordered pairs.

2. $y = 2x - 4$

3. $x + y = 12$

4. The equation $y = 23x$ describes the approximate number of miles y that a car can go on x gallons of gas. About how many miles can the car go on 20 gallons of gas?

5. **Standardized Test Practice** Which is *not* a linear function?

(A) $y = x$

(B) $y = -4$

(C) $y + x = 2$

(D) $y = 3 \div x$

ANSWERS

1.

x	$y = 3x - 1$	y	(x, y)
2	$3(2) - 1$	7	(2, 7)
0	$3(0) - 1$	-1	(0, -1)
2	$3(2) - 1$	5	(2, 5)
4	$3(4) - 1$	11	(4, 11)

2. Sample answers: (0, -4), (1, -2), (2, 0), (3, 2)

3. Sample answers: (0, 12), (4, 8), (6, 6), (7, 5)

4. The car can go about 460 miles on 20 gallons of gas.

5. D



5-Minute Check

(over Lesson-8-3)

Transparency 8-4

State the x -intercept and y -intercept of each line.

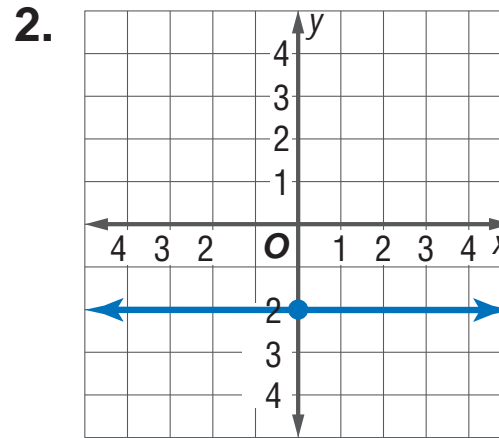
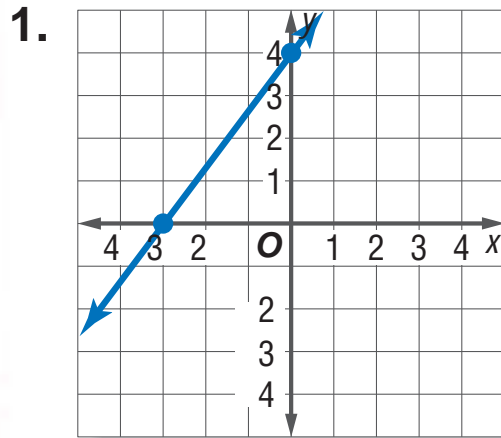

Find the x -intercept and y -intercept for the graph of each equation.

3. $y = x + 3$

4. $x + y = 5$

5. Graph $2x + y = 8$ using the x - and y -intercepts.

6. **Standardized Test Practice** What is the x -intercept of the graph of $y = 3x + 12$?

ANSWERS

1. $-3, 4$

2. none, -2

3. $-3, 3$

4. $5, 5$

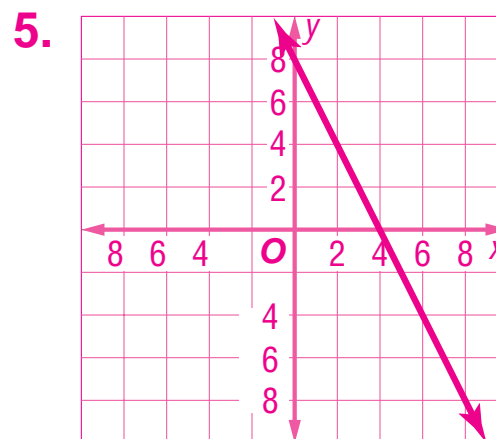

6. -4



5-Minute Check

(over Lesson 8-4)

Transparency 8-5

1. Find the slope of the line on the graph. $C(-4, -2)$, $D(5, 3)$

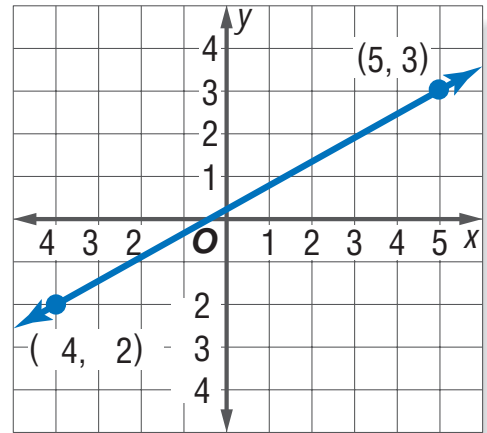

Find the slope of the line that passes through each pair of points.

2. $E(1, 4)$, $F(5, -2)$
3. $G(0, -7)$, $H(2, -7)$
4. $J(0, 0)$, $K(4, -4)$
5. Find the slope of a line that decreases 4 units vertically for every 10-unit horizontal increase.
6. **Standardized Test Practice** The slope of a line passing through the point $(5, -2)$ is undefined. Through which other point does the line pass?
- (A) $(-2, 5)$ (B) $(-5, -2)$
- (C) $(5, 2)$ (D) $(-5, 2)$

ANSWERS

1. $\frac{5}{9}$ 4. -1
2. $-\frac{3}{2}$ 5. $-\frac{2}{5}$
3. 0 6. C



5-Minute Check

(over Lesson 8-5)

Transparency 8-6

Find the rate of change for each linear function represented in the graph or table.

1.

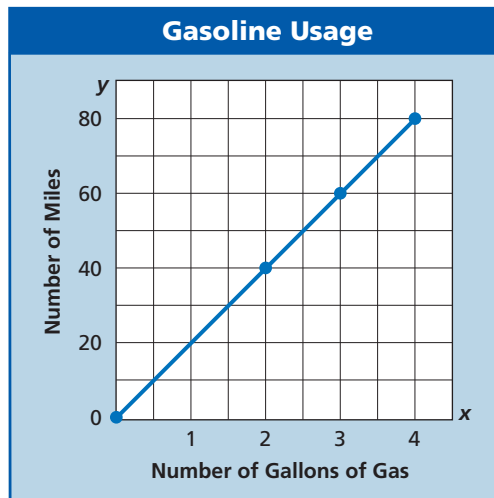

2.

Time (h)	Temperature (°F)
x	y
0	40
1	38
2	36
3	34

Suppose y varies directly with x . Write an equation relating x and y for each pair of values.

3. $y = 6$ when $x = 8$

4. $y = -20$ when $x = 5$

5. The cost of fencing varies directly with the number of feet of fencing purchased. If 1 foot of fencing costs \$1.75, find the cost of 200 feet.

6. **Standardized Test Practice** What is the y -intercept of the equation $y = 0.5x$?

ANSWERS

1. increase of
20 miles per gallon

2. decrease of
 2° per hour

3. $y = \frac{3}{4}x$

4. $y = -4x$

5. \$350.00

6. 0



5-Minute Check

(over Lesson 8-6)

Transparency 8-7

State the slope and the y -intercept for the graph of each equation.

1. $y = x + 5$ 2. $y = \frac{1}{2}x - 3$ 3. $x + y = 4$

4. Graph $y = 3x + 1$ using the slope and the y -intercept.

5. The printer charged a flat rate of \$65.00 to print invitations, plus an additional charge of \$0.15 per invitation for the art on them. Write an equation to show the total cost t of buying x invitations.

6. **Standardized Test Practice** Write $3x + 2y = 6$ in slope-intercept form.

ANSWERS

1. slope = 1,
 y -intercept = 5

2. slope = $\frac{1}{2}$,
 y -intercept = -3

3. slope = -1 ,
 y -intercept = 4

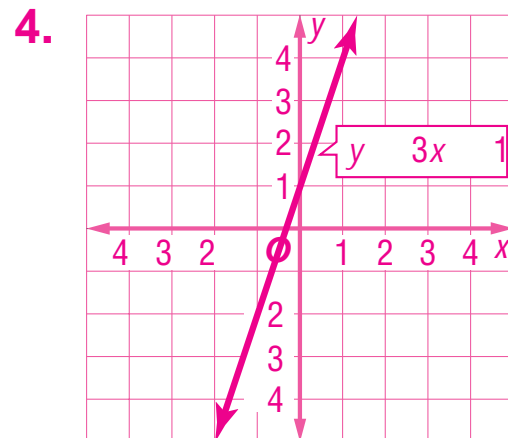

5. $t = 0.15x + 65$

6. $y = -\frac{3}{2}x + 3$



5-Minute Check

(over Lesson 8-7)

Transparency 8-8

Write an equation in slope-intercept form for each line.

1. slope = 1, y -intercept = -1
2. slope = $\frac{1}{4}$, y -intercept = 0
3. Write an equation in slope-intercept form for the line passing through the pair of points $(1, 1)$ and $(-1, -7)$.
4. Write an equation in slope-intercept form for the table of values.

x	-2	0	2	4
y	5	3	1	-1

5. **Standardized Test Practice**
- The charges for a long distance telephone company are shown in the table. Which equation shows the cost y for x minutes of phone calls in a month?

Charges per Month	
Flat rate	\$5.00
Per minute of calling	\$0.07

- (A) $y = 0.07x + 5$ (B) $y = 5x + 0.07$
- (C) $y = 7x + 5$ (D) $y = 0.07 - 5$

ANSWERS

1. $y = x - 1$ 4. $y = -x + 3$
2. $y = \frac{1}{4}x$ 5. A
3. $y = 4x - 3$



5-Minute Check

(over Lesson 8-8)

Transparency 8-9

The table shows the women's winning Olympic javelin throw distances to the nearest meter.

Year	1976	1980	1984	1988	1992	1996	2000
Distance (m)	66	68	70	75	68	68	69

1. Make a scatter plot of the data and draw a best-fit line.
2. Use the best-fit line to predict the winning javelin throw distance in the 2004 Olympics.
3. **Standardized Test Practice** For which of the following would the scatter plot of data show no relationship?
 - (A) distance traveled and gas left in the tank of a car
 - (B) color of a car and its miles per gallon
 - (C) number of pizzas ordered and total bill
 - (D) a child's age and the child's height

ANSWERS

1. Sample answer: See graph at right.
2. Sample answer: 73 m
3. B

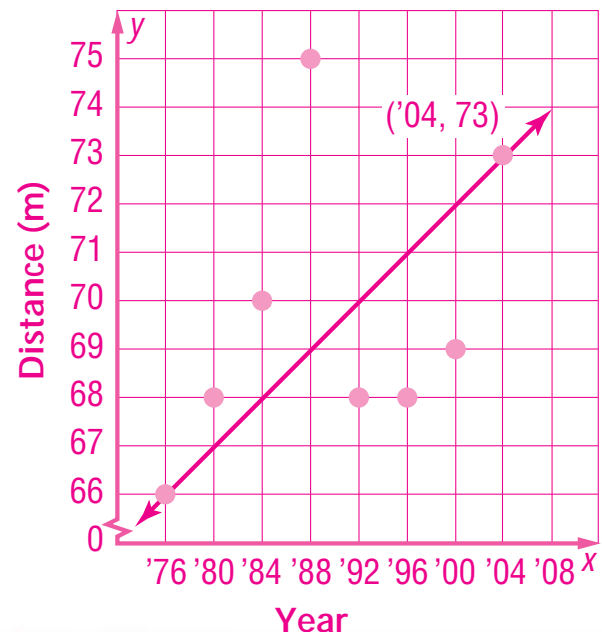



5-Minute Check

(over Lesson 8-9)

Transparency 8-10

1. State the solution of the system of equations graphed at the right.

2. Solve the system of equations by graphing.

$$y = x + 1$$

$$y = -x + 3$$

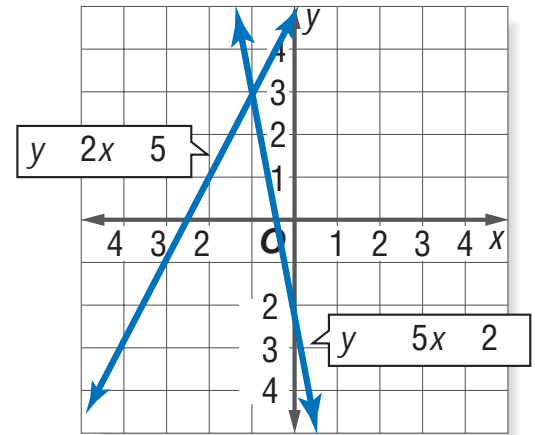

Solve each system of equations by substitution.

3. $y = x - 3$

$$y = 0$$

4. $y = x + 5$

$$y = -1$$

5. $x + y = 2$

$$y = 4$$

6. **Standardized Test Practice** Which system of equations has no solution?

(A) $y = 4x - 3$

$$y = 3x - 4$$

(B) $y = x - 4$

$$y = x + 4$$

(C) $y = 2x + 1$

$$y = -2x + 1$$

(D) $y = 3x$

$$y = \frac{1}{3}x$$

ANSWERS

1. $(-1, 3)$

2. See graph at right.

3. $(3, 0)$

4. $(-6, -1)$

5. $(4, -2)$

6. B

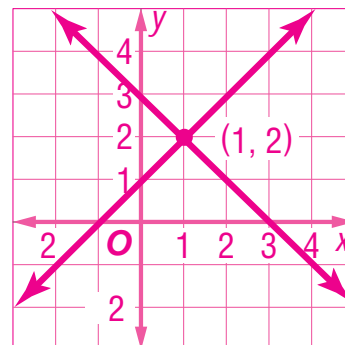



5-Minute Check

(over Chapter 8)

Transparency 9-1

- Determine whether the relation is a function. Explain.
 $\{(-1, -2), (0, -1), (-2, 1), (0, 2)\}$
- Find the x -intercept and y -intercept for the graph of $2x + y = 6$.
- Find the slope of the line that passes through the pair of points $A(4, 2)$ and $B(-4, -4)$.
- Solve the system of equations by substitution.
 $x + y = 10$
 $y = 4x$
- State the slope and the y -intercept for the graph of the equation $x + 2y = -8$.
- Standardized Test Practice** Which ordered pair is *not* a solution of $y \leq 3x + 2$?

(A) $(1, -1)$	(B) $(-2, -5)$
(C) $(-2, -3)$	(D) $(-1, -1)$

ANSWERS

- | | |
|-------------------------------------|-----------------------|
| 1. No; 0 is paired with -1 and 2. | 4. $(2, 8)$ |
| 2. 3, 6 | 5. $-\frac{1}{2}, -4$ |
| 3. $\frac{3}{4}$ | 6. C |



5-Minute Check

(over Lesson 9-1)

Transparency 9-2

Find each square root, if possible.

1. $\sqrt{49}$

2. $\sqrt{-81}$

Estimate each square root to the nearest whole number. Do not use a calculator.

3. $-\sqrt{85}$

4. $\sqrt{70}$

5. The area of a square is 200 cm^2 . Estimate the length of a side of the square.

6. **Standardized Test Practice** Between what two integers is $-\sqrt{30}$?

ANSWERS

1. 7

2. not possible

3. -9

4. 8

5. 14 cm

6. between -5 and -6



5-Minute Check

(over Lesson 9-2)

Transparency 9-3

1. Name all of the sets of real numbers to which $0.545454\dots$ belongs.
2. Replace the \bullet with $<$, $>$, or $=$ to make a true statement.
 $\sqrt{38} \bullet 6\frac{1}{4}$
3. Order $3.\bar{2}$, $\sqrt{10}$, $3\frac{1}{5}$, $\frac{7}{2}$ from least to greatest.
4. Solve $y^2 = 12$. Round to the nearest tenth, if necessary.
5. Use the formula $r = \sqrt{\frac{A}{\pi}}$, where A is the area of the circle to find the radius of a circle whose area is 145 square feet.
6. **Standardized Test Practice** Which number is *not* irrational?

(A) $0.121121112\dots$	(B) $\sqrt{55}$
(C) $-\sqrt{1}$	(D) $-3.14159\dots$

ANSWERS

1. Q, R
2. $<$
3. $\sqrt{10}$, $3\frac{1}{5}$, $3.\bar{2}$, $\frac{7}{2}$
4. 3.5, -3.5
5. 6.8 feet
6. C



5-Minute Check

(over Lesson 9-3)

Transparency 9-4

Use a protractor to draw an angle having each measurement. Then classify each angle as *acute*, *obtuse*, *right*, or *straight*.

1. 100° 2. 180° 3. 45° 4. 135°

5. What type of angle is formed by the diagonal of a square and one of the sides of the square?

6. **Standardized Test Practice** A right angle is divided equally into two angles. The measure of one of those angles is tripled. What is the classification of an angle with this new measure?

ANSWERS

1. obtuse

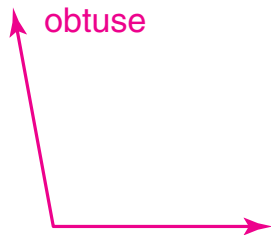

3. acute

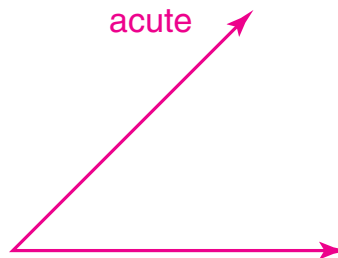

5. acute angle

6. obtuse

2. straight



4. obtuse

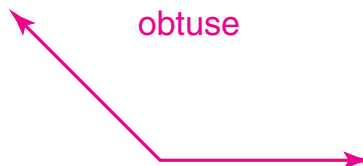



5-Minute Check

(over Lesson 9-4)

Transparency 9-5

Find the value of x in each triangle. Then classify each triangle as *acute*, *right*, or *obtuse*.

1.

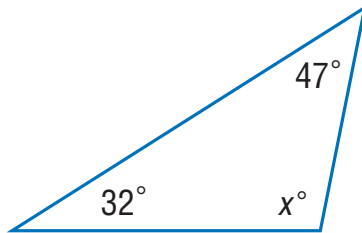

2.

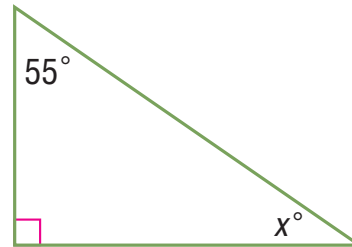

- The measures of the angles of a triangle are in the ratio 2:3:4. What is the measure of each angle?
- The measures of the angles of a triangle are in the ratio 1:1:7. What is the measure of the obtuse angle of the triangle?
- Determine whether the statement is *sometimes*, *always*, or *never* true. *A scalene triangle has two congruent sides.*
- Standardized Test Practice** Classify the triangle at the right by its angles and by its sides.



ANSWERS

- 101°; obtuse
- 35°; right
- 40°, 60°, 80°

- 140°
- never
- obtuse, isosceles



5-Minute Check

(over Lesson 9-5)

Transparency 9-6

If c is the measure of the hypotenuse, find each missing measure. Round to the nearest tenth, if necessary.

1. $a = 8, b = 15, c = ?$

2. $a = 6, b = ?, c = 16$

The lengths of three sides of a triangle are given. Determine whether each triangle is a right triangle.

3. $a = 7, b = 24, c = 25$

4. $a = 10, b = 12, c = 15$

5. A computer screen has a diagonal of 14 inches. The width of the screen is 11 inches. Find the height of the screen. Round to the nearest tenth, if necessary.

6. **Standardized Test Practice** What is the length of the diagonal of the square shown?

(A) 8.5 in.

(B) 12.7 in.

(C) 6 in.

(D) 9 in.

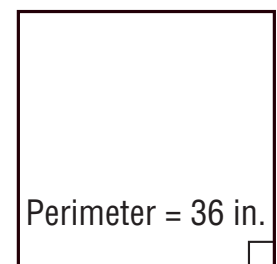

ANSWERS

1. 17

4. no

2. 14.8

5. 8.7 in.

3. yes

6. B



5-Minute Check

(over Lesson 9-6)

Transparency 9-7

Find the distance between each pair of points.
Round to the nearest tenth, if necessary.

1. $A(2, -3), B(8, 5)$ 2. $C(4, -1), D(-3, -4)$

3. Find the coordinates of the midpoint of the segment with endpoints $G(-5, 0)$ and $H(-1, 6)$.

4. Find the perimeter of the figure shown. Round to the nearest tenth, if necessary.

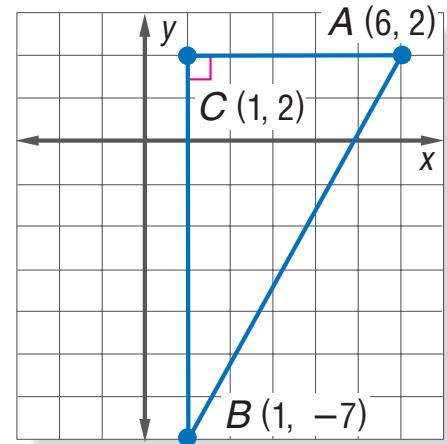

5. **Standardized Test Practice**

The design for a playground is shown on the grid. The water fountain will be placed halfway between the swings and the slide. What will be the coordinates of the water fountain?

- (A) (1, 0) (B) (4, 0)
(C) (0, 1) (D) (1, 4)

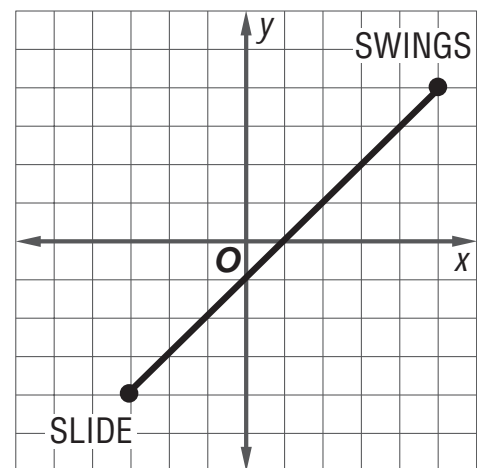

ANSWERS

1. 10 3. $(-3, 3)$ 5. A
2. 7.6 4. 24.3



5-Minute Check

(over Lesson 9-7)

Transparency 9-8

Use similar triangles ABC and DEF to answer Questions 1 and 2.

- Write a proportion to find the missing measure x . Then find the value of x .
- The measure of $\angle DFE = 37^\circ$. What is the measure of $\angle ACB$?

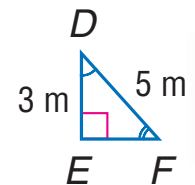
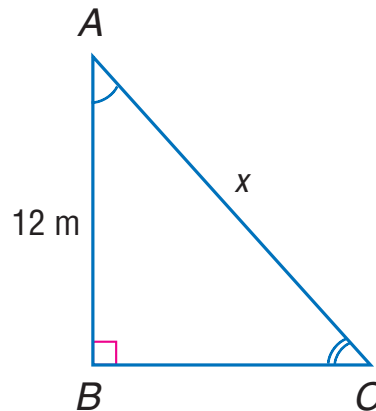

- Determine whether the statement is *always*, *sometimes* or *never* true. *Similar triangles have corresponding angles and sides equal.*
- At the same time that a flagpole casts a shadow 24 feet long, a 6-foot tall person casts a shadow 8 feet long. How tall is the flagpole?

- Standardized Test Practice**
Right triangles ABC and XYZ are similar. AC is the hypotenuse of $\triangle ABC$. Use the information in the table to find XY and YZ .

$\triangle ABC$	$\triangle XYZ$
$AB = 3$ in.	XY
$BC = 4$ in.	YZ
AC	$XZ = 20$ in.

ANSWERS

- Sample answer: $\frac{AB}{AC} = \frac{DE}{DF}$; $x = 20$ m
- 37°
- sometimes
- 18 ft
- $XY = 12$ in., $YZ = 16$ in.



5-Minute Check

(over Chapter 9)

Transparency 10-1

1. Estimate $\sqrt{54}$ to the nearest whole number. Do not use a calculator.
2. Order $3.\overline{13}$, $\sqrt{10}$, $3\frac{1}{3}$, $\sqrt{9}$ from least to greatest.
3. If c is the measure of the hypotenuse and $a = 6$ and $b = 9$, find the measure of c . Round to the nearest tenth, if necessary.
4. Find the distance between $A(-3, 4)$ and $B(5, 2)$ to the nearest tenth. Then find the coordinates of the midpoint of \overline{AB} .

5. **Standardized Test Practice**
Triangle ABC is isosceles.
What is the measure of angle B ?

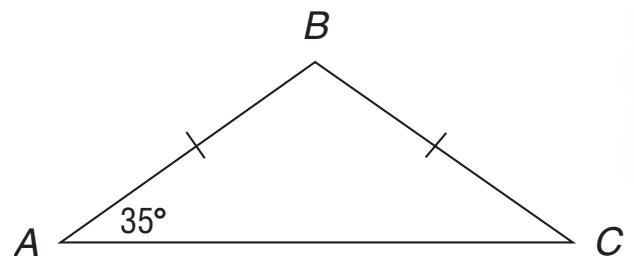

ANSWERS

1. 7
2. $\sqrt{9}$, $3.\overline{13}$, $\sqrt{10}$, $3\frac{1}{3}$
3. 10.8 units
4. 8.2 units; (1, 3)
5. 110°



5-Minute Check

(over Lesson 10-1)

Transparency 10-2

Use the figure for Questions 1 and 2. In the figure, $a \parallel b$ and t is a transversal. If $m\angle 3 = 37^\circ$, find the measure of each angle.

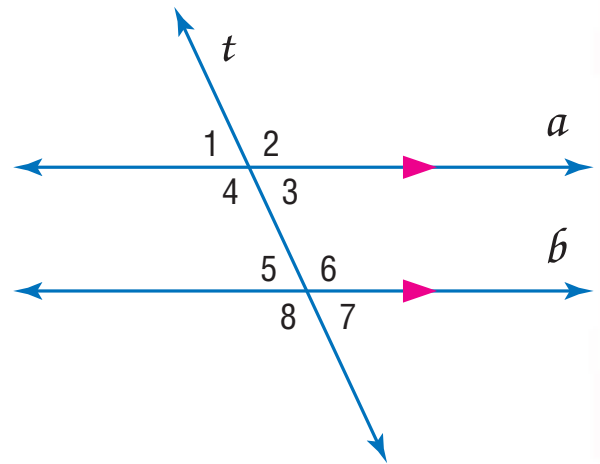

1. $m\angle 8$
2. $m\angle 7$
3. If $\angle A$ and $\angle B$ are supplementary, $m\angle A = 3x - 7$, and $m\angle B = 2x - 3$, what is the measure of each angle?
4. A ladder is leaning against a house. The ladder meets the house at an angle that is complementary to 32° . At what angle does the ladder meet the house?
5. **Standardized Test Practice**
If $\overline{AB} \parallel \overline{CD}$ and $\overline{BC} \parallel \overline{AD}$, find $m\angle A$.

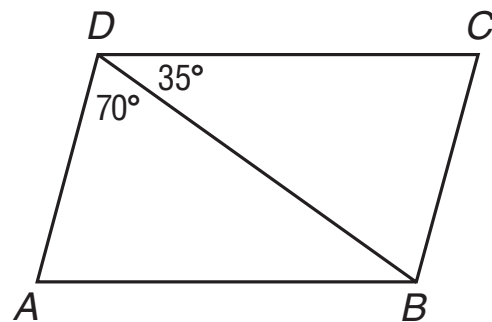

ANSWERS

1. 143°
2. 37°
3. $m\angle A = 107^\circ$, $m\angle B = 73^\circ$
4. 58°
5. 75°



5-Minute Check

(over Lesson 10-2)

Transparency 10-3

1. Name the corresponding parts for the pair of congruent triangles. Then complete the congruence statement.

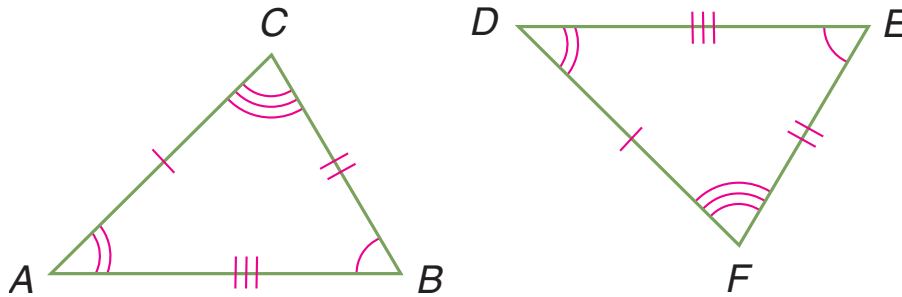

$$\triangle ACB \cong \triangle \underline{\quad? \quad}$$

Complete each congruence statement if

$$\triangle PNO \cong \triangle KML.$$

2. $\angle N \cong \underline{\quad? \quad}$

3. $\overline{LK} \cong \underline{\quad? \quad}$

4. **Standardized Test Practice** Which of the following must be true if $\triangle PQR \cong \triangle KLM$?

(A) $\angle Q \cong \angle L$

(B) $\overline{LK} = \overline{RP}$

(C) $\overline{QR} = \overline{KM}$

(D) $\angle RQP \cong \angle LMK$

ANSWERS

1. $\angle A \cong \angle D$, $\angle B \cong \angle E$, $\angle C \cong \angle F$, $\overline{AB} = \overline{DE}$, $\overline{BC} = \overline{EF}$,
 $\overline{CA} = \overline{FD}$; DFE

2. $\angle M$

3. \overline{OP}

4. A



5-Minute Check

(over Lesson 10-3)

Transparency 10-4

1. Triangle XYZ has vertices $X(-3, 1)$, $Y(0, -2)$, and $Z(4, 3)$. Find the coordinates of the vertices after a translation 2 units right and 3 units down.
2. Triangle EFG has vertices $E(3, 1)$, $F(0, 5)$, and $G(-4, 3)$. Find the coordinates of the vertices after a reflection over the x -axis.
3. The vertices of the figure $ABCD$ are $A(-1, -2)$, $B(-4, 0)$, $C(-3, -5)$, and $D(-5, -3)$. Find the coordinates of the vertices of the figure after a rotation of 90° clockwise.
4. The vertices of $\triangle XYZ$ are $X(-1, -2)$, $Y(-4, 0)$, and $Z(-3, -5)$. The vertices of $\triangle XYZ$ after a translation are $X(-4, -1)$, $Y(-7, 1)$, and $Z(-6, -4)$. Write the translation as an ordered pair.

5. **Standardized Test Practice** If $\triangle DEF$ is reflected over the y -axis, in which quadrant will the image of $\triangle DEF$ be?

(A) I

(B) II

(C) III

(D) IV

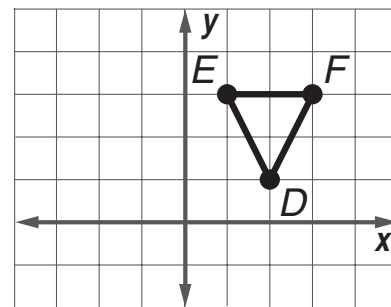

ANSWERS

1. $X'(-1, -2)$, $Y'(2, -5)$, and $Z'(6, 0)$
2. $E'(3, -1)$, $F'(0, -5)$, and $G'(-4, -3)$
3. $A'(-2, 1)$, $B'(0, 4)$, $C'(-5, 3)$, and $D'(-3, 5)$
4. $(-3, 1)$
5. B



5-Minute Check

(over Lesson 10-4)

Transparency 10-5

Find the value of x . Then find the missing angle measures.

1.

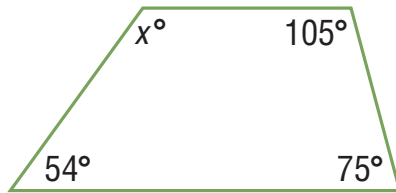

2.

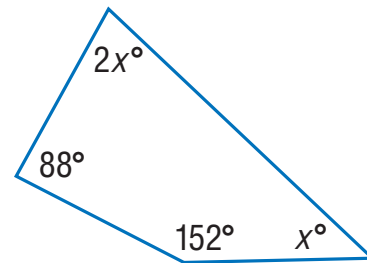

Classify each quadrilateral using the name that best describes it.

3.

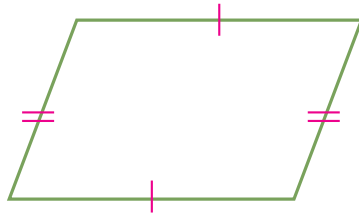

4.

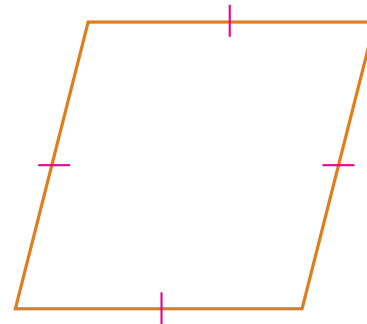

5. **Standardized Test Practice** Which statement is *not* true?

- (A) A trapezoid is a quadrilateral.
- (B) A rhombus is a square.
- (C) A square is a rectangle.
- (D) A rectangle is a parallelogram.

ANSWERS

1. 126°

4. rhombus

2. $x = 40$; 40° , 80°

5. B

3. parallelogram



5-Minute Check

(over Lesson 10-5)

Transparency 10-6

Find the area of each figure.

1.

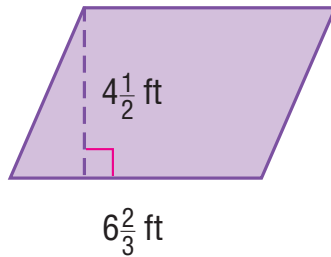

2.

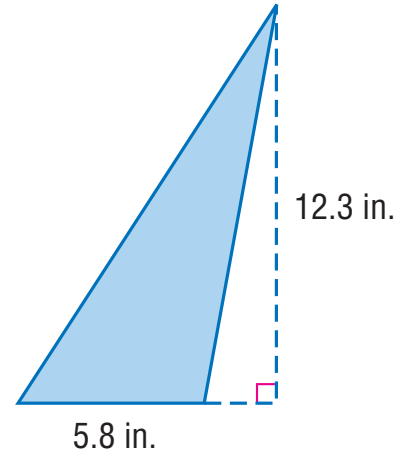

3. Find the area of a triangle with base 2.6 km and height 4 km.

4. The area of a college basketball court is 4200 square feet. The width of the court is 50 feet. What is the length of the court?

5. **Standardized Test Practice**
What is the area of the figure?

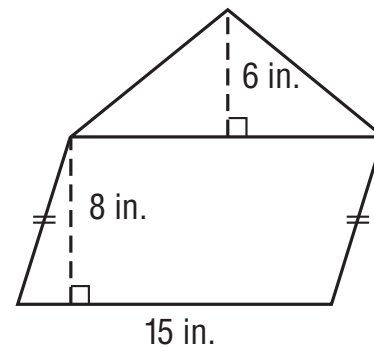

ANSWERS

1. 30 ft^2
2. 35.67 in^2
3. 5.2 km^2
4. 84 ft
5. 165 in^2



5-Minute Check

(over Lesson 10-6)

Transparency 10-7

Classify each polygon. Then determine whether it appears to be *regular* or *not regular*.

1.

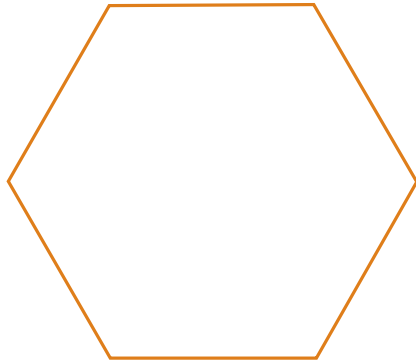

2.

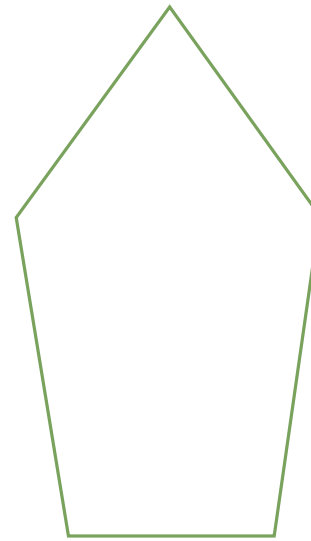

- Find the measure of each interior angle of a regular hexagon.
- The base of a light fixture is in the shape of an octagon. Each side of the base is 4.5 inches. What is the perimeter of the base?
- Standardized Test Practice** An interior angle of a regular polygon has a measure of 140° . How many sides does the polygon have?

(A) 6

(B) 7

(C) 9

(D) 12

ANSWERS

1. hexagon; regular

4. 36 in.

2. pentagon; not regular

5. C

3. 120°



5-Minute Check

(over Lesson 10-7)

Transparency 10-8

Find the circumference and area of each circle to the nearest tenth.

1.

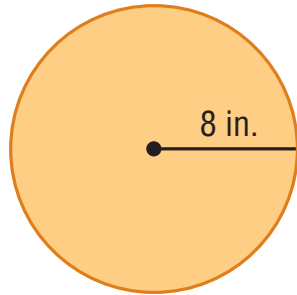

2.

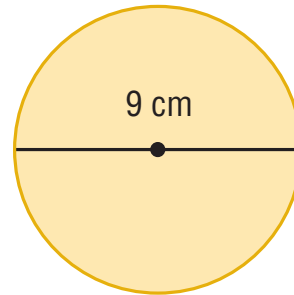

3. The diameter of a circle is 5.7 feet. Find the circumference and area to the nearest tenth.
4. The diameter of the lid of a coffee can is $3\frac{1}{4}$ inches. What is the circumference of the lid to the nearest tenth?

5. **Standardized Test Practice** A circle with a radius of 1 foot is to be cut from a square of plywood that is 2 feet on each side. What will be the approximate area of the remaining board?

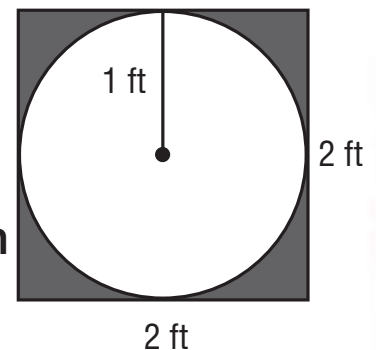

- (A) 4 ft^2 (B) 3.14 t^2 (C) 7.14 ft^2 (D) 0.86 ft^2

ANSWERS

1. 50.3 in., 201.1 in² 4. 10.2 in.
2. 28.3 cm, 63.6 cm² 5. D
3. 17.9 ft, 25.5 ft²



5-Minute Check

(over Chapter 10)

Transparency 11-1

1. If $\triangle FOG \cong \triangle HAT$, name the segment that is congruent to \overline{TH} .
2. The vertices of figure $WXYZ$ are $W(2, 3)$, $X(4, 5)$, $Y(5, -1)$, and $Z(1, -2)$. Find the coordinates of the image after a reflection over the y -axis.

3. Find the value of x in the figure at the right. Then find the missing angle measures.

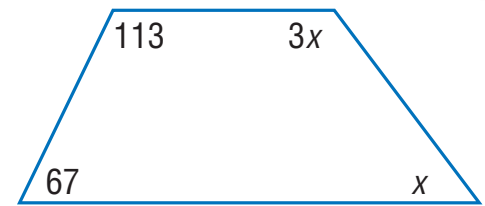

4. Find the area of a triangle with a base of 34 centimeters and a height of 19 centimeters.
5. A round table has a diameter of 25 inches. What is the circumference of the table? Round to the nearest tenth.

6. **Standardized Test Practice** The exterior angle at each vertex of a regular polygon measures 72° . What type of polygon is it?

- (A) equilateral triangle (B) square
(C) regular pentagon (D) regular hexagon

ANSWERS

1. \overline{GF}
2. $W'(-2, 3)$, $X'(-4, 5)$,
 $Y'(-5, -1)$, and
 $Z'(-1, -2)$
3. $x = 45^\circ$; 45° , 135°
4. 323 cm^2
5. 78.5 in.
6. C



5-Minute Check

(over Lesson 11-1)

Transparency 11-2

Use the figure of the solid at the right to answer Questions 1–4.

1. Name the faces of the rectangular prism.
2. List the edges of the solid.
3. Identify a diagonal of the solid.
4. Name four segments skew to \overline{WV} .

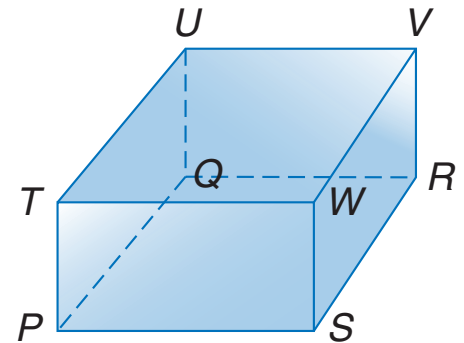

5. Determine whether the statement is *sometimes*, *always*, or *never* true. *A triangular prism can be used to show skew lines.*

6. **Standardized Test Practice** How many faces of a triangular prism are triangles?

- | | |
|-------|-------|
| (A) 3 | (B) 2 |
| (C) 5 | (D) 6 |

ANSWERS

1. $PTUQ$, $QUVR$, $PQRS$, $SWVR$, $PTWS$, and $TUVW$
2. \overline{PT} , \overline{QU} , \overline{RV} , \overline{SW} , \overline{PS} , \overline{SR} , \overline{RQ} , \overline{PQ} , \overline{TU} , \overline{UV} , \overline{VW} , and \overline{WT}
3. \overline{PV} , \overline{QW} , \overline{RT} , or \overline{SU}
4. \overline{TP} , \overline{QU} , \overline{PS} , and \overline{QR}
5. always
6. B



5-Minute Check

(over Lesson 11-2)

Transparency 11-3

Find the volume of each solid. If necessary, round to the nearest tenth.

1.

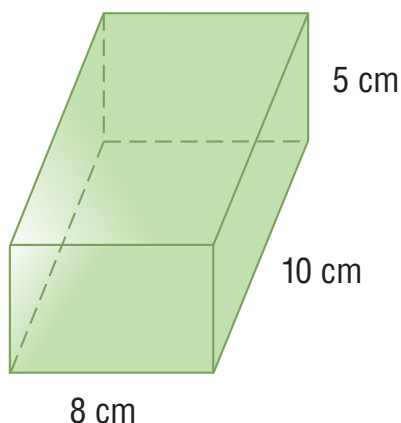

2.

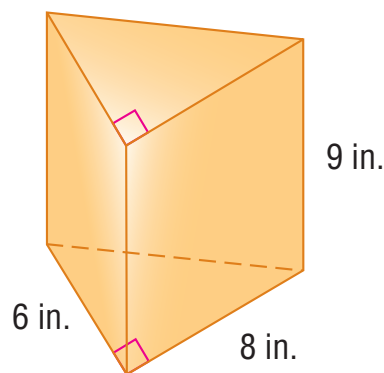

3. Find the height of a cylinder with a radius of 3 feet and a volume of 127.2 ft^3 . Round to the nearest tenth.
4. A cubic inch of water weighs 0.036 pound. A 10-gallon fish tank measures 20 inches by 10 inches by 12 inches. How much will the water in the fish tank weigh if it is filled to capacity?

5. **Standardized Test Practice** Which is the best estimate for the volume of a rectangular prism with the dimensions shown in the table?

Dimensions	
length	5.8 in.
width	2.1 in.
height	9.7 in.

- (A) 60 in^3 (B) 240 in^3
(C) 120 in^3 (D) 6.0 in^3

ANSWERS

1. 400 cm^3 2. 216 in^3 3. 4.5 feet
4. 86.4 pounds 5. C



5-Minute Check

(over Lesson 11-3)

Transparency 11-4

Find the volume of each solid. If necessary, round to the nearest tenth.

1.

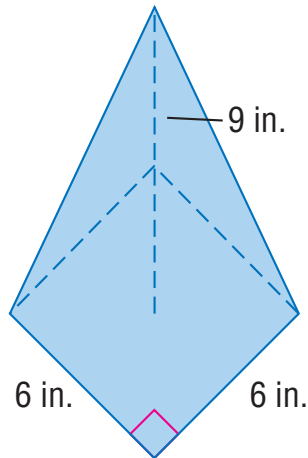

2.

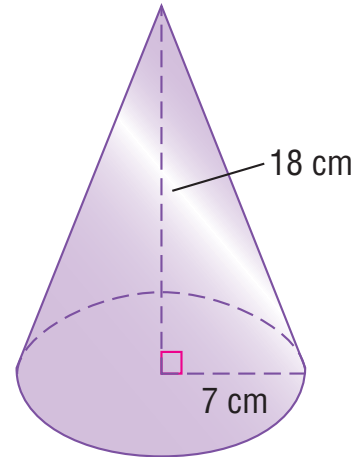

3. rectangular pyramid: base area 31.5 ft^2 , height 7.4 ft

4. hexagonal pyramid: base area 120 mm^2 , height 9 mm

5. A cone has a radius of 1.2 inches and a height of 5 inches. What is the volume of the cone?

6. **Standardized Test Practice** A cylinder and a cone have the same volume. Both the cylinder and the cone have a radius of 3 inches. If the height of the cone is 6 inches, what is the height of the cylinder?

ANSWERS

1. 108 in^3

2. 923.6 cm^3

3. 77.7 ft^3

4. 360 mm^3

5. 7.5 in^3

6. 2 in.



5-Minute Check

(over Lesson 11-4)

Transparency 11-5

Find the surface area of each solid.
If necessary, round to the nearest tenth.

1.

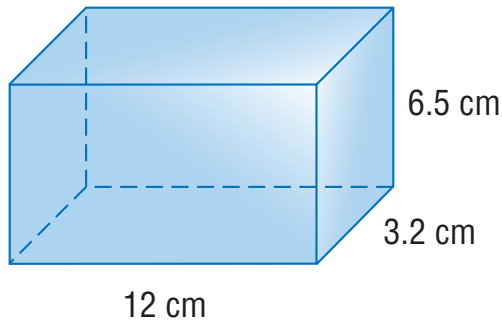

2.

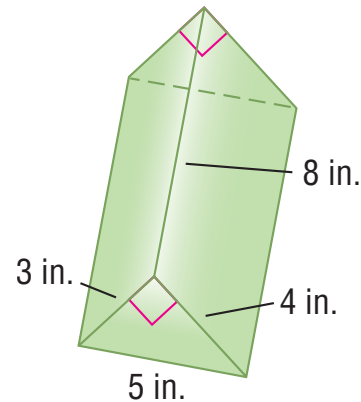

3. cylinder: diameter 12 cm, height 29 cm
4. cube: side length of 0.8 m
5. Amy needs to wrap a box that is 18 inches long, 11 inches wide, and 3 inches high. What is the minimum amount of wrapping paper that she needs?
6. **Standardized Test Practice** To the nearest square inch, how much area does the label of the can cover?

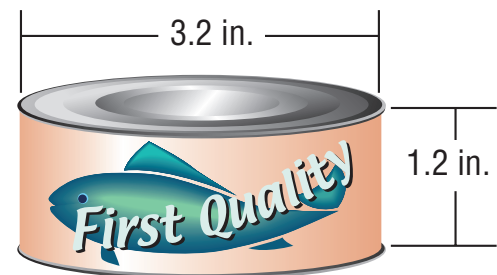

ANSWERS

- | | |
|--------------------------|-----------------------|
| 1. 274.4 cm^2 | 4. 3.8 m^2 |
| 2. 108 in^2 | 5. 570 in^2 |
| 3. 1319.5 cm^2 | 6. 12 in^2 |



5-Minute Check

(over Lesson 11-5)

Transparency 11-6

Find the surface area of each solid. If necessary, round to the nearest tenth.

1.

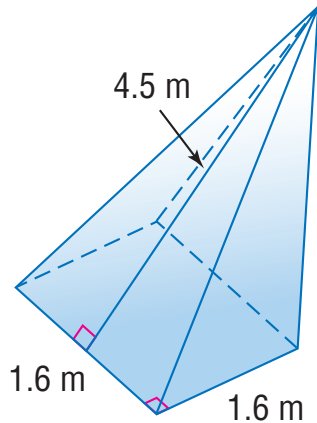

2.

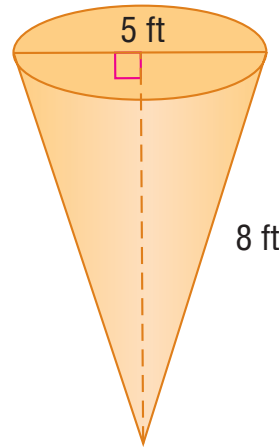

3. An ice cream cone has a radius of 1.2 inches, and a slant height of 6 inches. What is the lateral surface area of the cone?

4. **Standardized Test Practice** An ornament has the shape of 2 regular pentagonal pyramids attached at their bases. The length of each side of the pentagon is 1 inch, and the slant height of each pyramid is 2 inches. What is the surface area of the ornament?

(A) 5 in^2

(B) 10 in^2

(C) 20 in^2

(D) 25 in^2

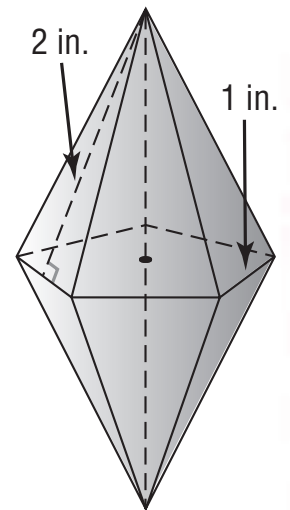

ANSWERS

1. 10.6 m^2

2. 82.5 ft^2

3. 22.6 in^2

4. B



5-Minute Check

(over Lesson 11-6)

Transparency 11-7

Find the missing measures for the pair of similar solids.

1. $x = ?$

2. $y = ?$

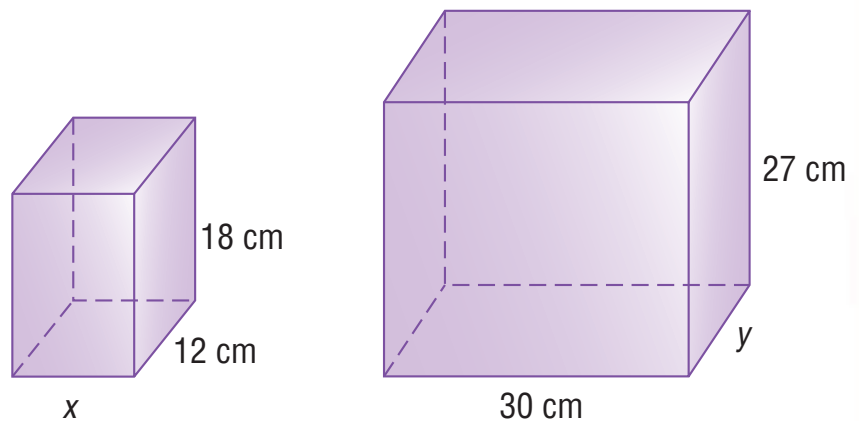

3. Mark is making a scale model of the Great Pyramid in Egypt. The pyramid was originally about 480 feet high, and the base was a square 756 feet on a side. If Mark makes his model 6 inches high, what length should he use for the base?

4. **Standardized Test Practice** The volumes of two similar solids are in the ratio $\frac{64}{27}$. What is the ratio of the surface areas of the solids?

ANSWERS

1. 20 cm

2. 18 cm

3. 9.45 in.

4. $\frac{16}{9}$



5-Minute Check

(over Chapter 11)

Transparency 12-1

Find the volume of each solid. If necessary, round to the nearest tenth.

1. cylinder: radius 2.3 cm, height 9 cm
2. rectangular pyramid: length 12 in., width 8 in., height 11 in.

Find the surface area of each solid. If necessary, round to the nearest tenth.

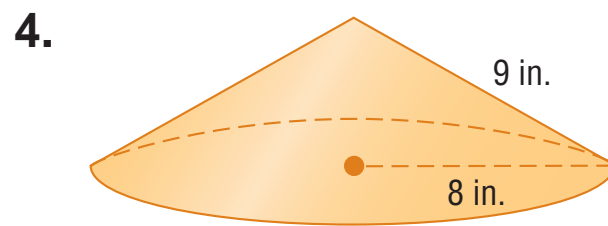
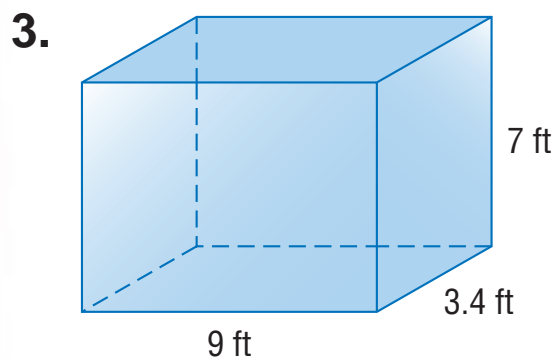

5. A model for a new movie theater is 55 centimeters tall. On the model, 1 centimeter represents 5 meters. How tall is the actual theater?
6. **Standardized Test Practice** A cone and a cylinder have the same radius and the same height. The volume of the cone is 48 cm^3 . What is the volume of the cylinder?

ANSWERS

- | | |
|-------------------------|-------------------------|
| 1. 149.6 cm^3 | 4. 427.3 in^2 |
| 2. 352 in^3 | 5. 275 meters |
| 3. 234.8 ft^3 | 6. 144 cm^3 |



5-Minute Check

(over Lesson 12-1)

Transparency 12-2

Use the data in the table for Questions 1–4.

Tallest Buildings in Denver, Colorado

Name	Stories	Name	Stories
17th Street Plaza	32	One Denver Place	34
1999 Broadway	43	One Norwest Center	52
Amoco Building	36	Qwest Tower	40
Brooks Towers	42	Republic Plaza	56
First Interstate Tower North	32	Tabor Center	32
MCI Tower	42	US West Tower	54

Source: *The World Almanac*

1. Display the data in a stem-and-leaf plot.
2. How many buildings have 32 stories?
3. How many buildings have more than 40 stories?
4. What is the median number of stories for the data set?
5. **Standardized Test Practice** Which stem-and-leaf plot key represents the number 108?

(A) 1 | 8

(B) 1 | 08

(C) 10 | 8

(D) 8 | 10

ANSWERS

1. Stem | Leaf

5	2 4 6
4	0 2 2 3
3	2 2 2 4 6

3|2 = 32 stories

2. 3 buildings

3. 6 buildings

4. 41 stories

5. C



5-Minute Check

(over Lesson 12-2)

Transparency 12-3

Use the data in the table for Questions 1–2.

Region	Highest Average Annual Precipitation (inches)	Elevation (feet)
South America	524	520
Asia	467	4597
Oceania	460	5148
Africa	405	30
South America	354	120
Australia	340	5102
North America	256	12
Europe	183	3337

Source: *The World Almanac*

1. Find the interquartile range of the data for the highest average annual precipitation and for the elevation.
2. For which set of data is the middle data more clustered about the median? Explain.
3. **Standardized Test Practice** Which is the least measure for the data set {73, 81, 60, 94, 48, 57, 68}?
 (A) range (B) median
 (C) lower quartile (D) interquartile range

ANSWERS

1. 165.5; 4774.5
2. Sample answer: The data for the average annual precipitation is more clustered around the median because the interquartile range is smaller.
3. D



5-Minute Check

(over Lesson 12-3)

Transparency 12-4

1. Draw a box-and-whisker plot for {\\$125, \\$93, \\$111, \\$101, \\$125, \\$115, \\$90, \\$150, \\$99, \\$120}.

Use the box-and-whisker plot for Questions 2–3.

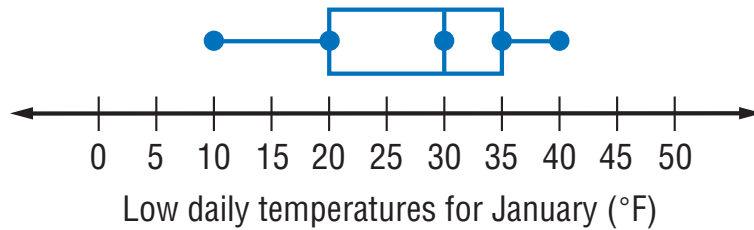

2. What percent of the data is between 20°F and 35°F ?
3. Write a sentence describing the data for January.

4. **Standardized Test Practice**

Which does the number 100 represent on the plot?

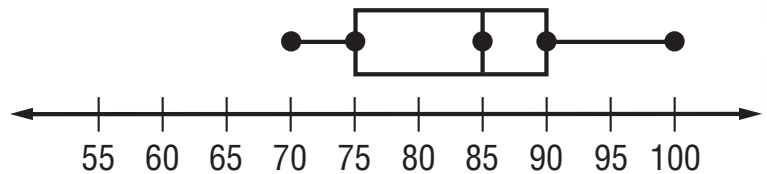

- | | |
|--|---|
| <input type="radio"/> (A) extreme | <input type="radio"/> (B) median |
| <input type="radio"/> (C) lower quartile | <input type="radio"/> (D) interquartile range |

ANSWERS

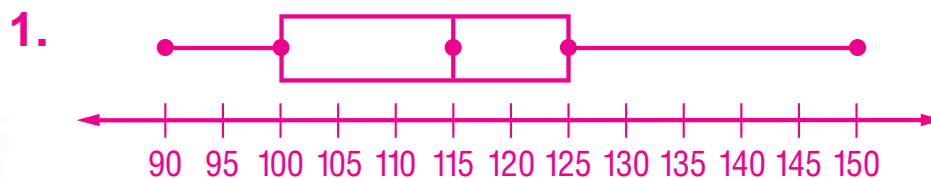

2. 50%
3. Sample answer: The low daily temperatures for January ranged from 10°F to 40°F with most between 20°F and 35°F .
4. A



5-Minute Check

(over Lesson 12-4)

Transparency 12-5

Use the data in the histogram for Questions 1–4.

1. What are the intervals on the histogram?
2. How many countries won between 1 and 10 medals?
3. How many countries won medals at the 1998 Winter Olympics?
4. Is it possible to tell the largest number of medals won by a country? Explain.

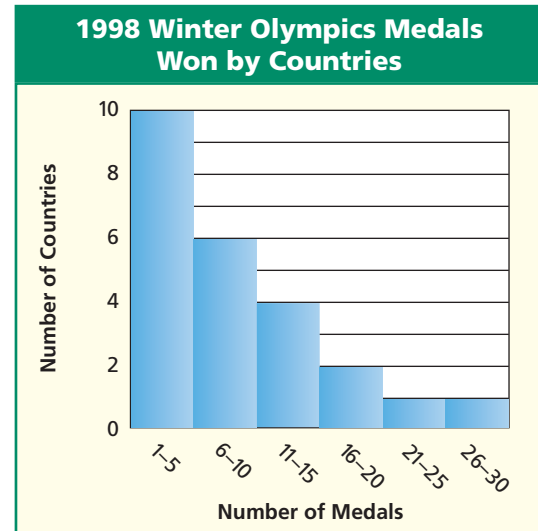

5. **Standardized Test Practice**
The histogram shows the average amount of monthly precipitation in a city. How many months average at least 3 inches of rain?

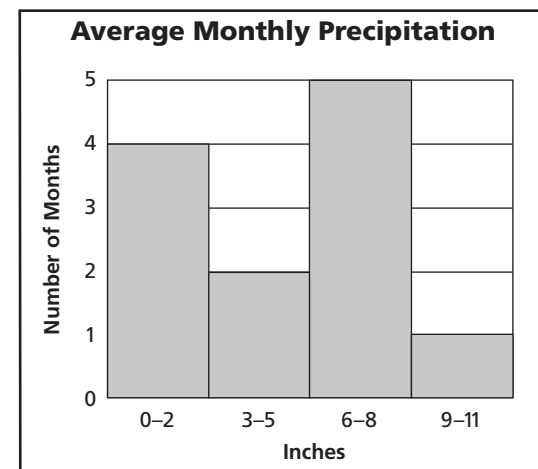

ANSWERS

1. 5
2. 16 countries
3. 24 countries
4. Sample answer: It is only possible to tell that one country won between 26 and 30 medals.
5. 8



5-Minute Check

(over Lesson 12-5)

Transparency 12-6

For Questions 1-2, refer to the graphs below.

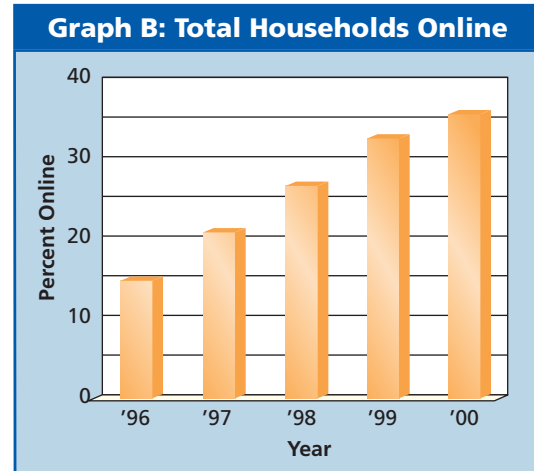
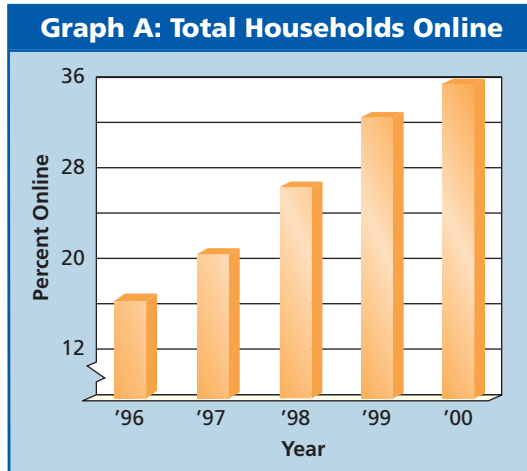

1. What causes the graphs to appear different?
2. Which graph is misleading? Explain your answer.
3. **Standardized Test Practice** Refer to the graph. Which statement best describes the change in cell phone subscribers from 1997 to 2000?

- (A) It doubled.
- (B) It tripled.
- (C) It quadrupled.
- (D) It cannot be determined.

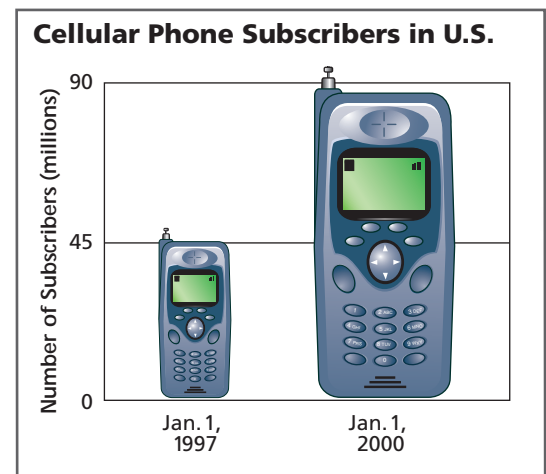

ANSWERS

1. The vertical scales are different.
2. Sample answer: Graph A is misleading because the increase in online households appears more drastic.
3. A



5-Minute Check

(over Lesson 12-6)

Transparency 12-7

1. Find the number of possible outcomes for the situation. *Lou has a choice of 4 sandwiches, 3 beverages, and 2 desserts.*
2. Two number cubes labeled 1 to 6 are rolled. What is the probability of getting an even number on both number cubes?
3. Three coins are tossed. What is the probability of getting all heads or all tails?
4. A wheel of chance has the numbers 1 to 42 once each, evenly spaced. What is the probability that a multiple of 7 will come up when the wheel is spun?
5. **Standardized Test Practice** A password is made using three components. The first component is any of the 26 letters of the alphabet, and the last two are each one-digit numbers from 0 through 9. How many possible passwords can be made?

(A) 260 (B) 2106 (C) 2600 (D) 2340

ANSWERS

1. 24 outcomes

2. $\frac{1}{4}$

3. $\frac{1}{4}$

4. $\frac{1}{7}$

5. C



5-Minute Check

(over Lesson 12-7)

Transparency 12-8

Tell whether each situation is a permutation or combination. Then solve.

1. How many ways can a president and vice president be chosen from the 8 people running for office?
2. An ice cream sundae shop has 9 toppings to choose from. How many different 3-topping sundaes can be ordered?

Find each value.

3. $4!$
4. $6!$
5. Find the number of line segments that can be drawn between any two vertices of a hexagon.

6. **Standardized Test Practice** How many different 4-letter codes can be formed from the letters shown if a letter is used only once in the code?

A	B	C	D	E	F	G
---	---	---	---	---	---	---

- (A) 840 (B) 5040 (C) 1260 (D) 210

ANSWERS

1. permutation; 56
2. combination; 84
3. 24
4. 720
5. 15
6. A



5-Minute Check

(over Lesson 12-8)

Transparency 12-9

Find the odds of each outcome if a pair of number cubes labeled 1 to 6 are rolled.

1. a sum greater than 11
2. a sum of 7
3. *not* a sum of 9
4. A bag contains 2 white, 4 red, and 3 black marbles. What are the odds against drawing a red marble from the bag?
5. What are the odds of spinning an even number?

6. **Standardized Test Practice** There are 12 white eggs and 1 brown egg in a basket. What are the odds of picking a white egg if one egg is chosen at random?

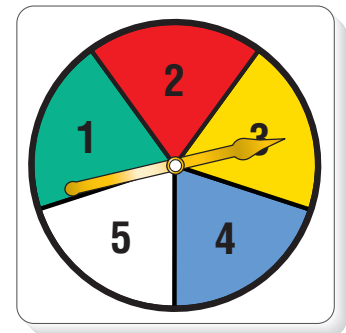

- | | |
|----------|----------|
| (A) 13:1 | (B) 12:1 |
| (C) 1:13 | (D) 1:12 |

ANSWERS

- | | |
|---------|--------|
| 1. 1:35 | 4. 5:4 |
| 2. 1:5 | 5. 2:3 |
| 3. 8:1 | 6. B |



5-Minute Check

(over Chapter 12)

Transparency 13-1

Use the stem-and-leaf plot for Questions 1–3.

1. What is the range of the data?
2. What is the median of the data?
3. What is the interquartile range of the data?

Stem	Leaf
4	0 1 5 7 7
5	2 8
6	4 5 9 9
	6 4 64

4. A box of chocolate candy contains 12 different pieces. How many ways can 2 different candies be chosen from the box?
5. A bag contains 4 blue marbles, 3 yellow marbles, and 5 red marbles. Once a marble is drawn, it is not replaced. Find the probability of picking a yellow marble, then a blue marble.
6. **Standardized Test Practice** How many different four-digit numbers can be formed using the digits 1, 2, 3, 4, and 5 if each digit can only be used once?

(A) 25

(B) 120

(C) 60

(D) 625

ANSWERS

1. 29

4. 66

2. 52

5. $\frac{1}{11}$

3. 20

6. B



5-Minute Check

(over Lesson 13-1)

Transparency 13-2

Determine whether each expression is a polynomial. If it is, classify it as a *monomial*, *binomial*, or *trinomial*.

1. $\frac{x^2}{3}$

2. $\frac{1}{y} + y$

3. $p^2 - 2pq + q^2$

4. Tell whether the statement is *always*, *sometimes*, or *never* true. A constant term has a degree of one.

5. The formula for the volume of ice cream in a cone is $\frac{4}{3}\pi r^3 + \frac{1}{3}\pi r^2h$. Find the degree of the polynomial.

6. **Standardized Test Practice** What is the degree of the polynomial expression for the area of the shaded figure?

(A) 4

(B) 3

(C) 2

(D) 1

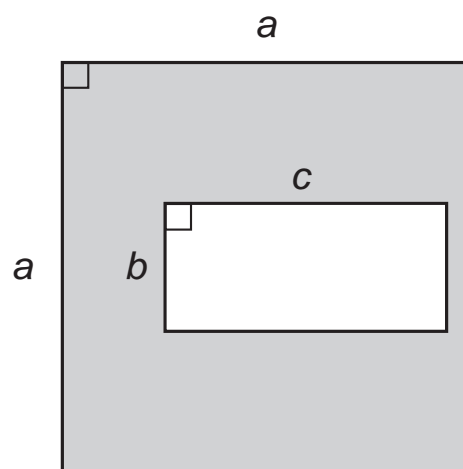

ANSWERS

1. yes; monomial

4. never

2. no

5. 3

3. yes; trinomial

6. C



5-Minute Check

(over Lesson 13-2)

Transparency 13-3

Find each sum.

$$\begin{array}{r} 1. \quad 6x - 2 \\ (+) 3x + 5 \\ \hline \end{array}$$

$$\begin{array}{r} 2. \quad 7x^2 + 3x - xy - y^2 \\ (+) 2x^2 \quad + 4xy \\ \hline \end{array}$$

$$3. (5x - 4y) + (8x - y)$$

$$4. (5x^2 + 4x - 7) + (-5x^2 - 2x + 6)$$

5. The length of a rectangle is represented by $4a^2 - 3$, and the width is represented by $2a + 1$. Find the perimeter of the rectangle.

6. **Standardized Test Practice** What is the measure of the smallest angle in the triangle?

(A) 28°

(B) 38°

(C) 56°

(D) 32°

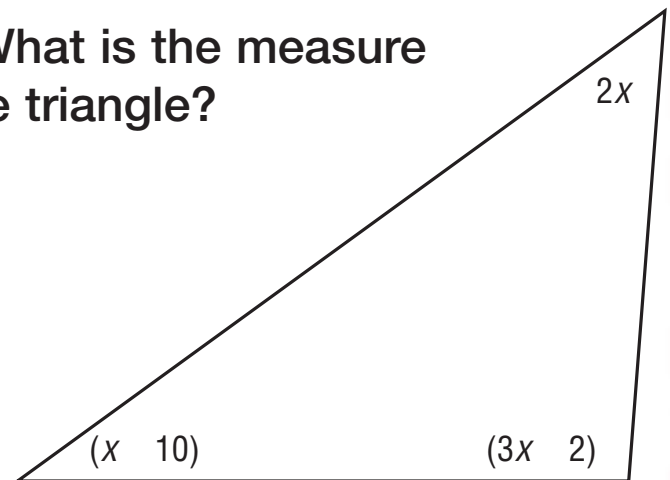

ANSWERS

1. $9x + 3$

2. $9x^2 + 3x + 3xy - y^2$

3. $13x - 5y$

4. $2x - 1$

5. $8a^3 + 4a^2 - 6a - 3$

6. B



5-Minute Check

(over Lesson 13-3)

Transparency 13-4

Find each difference.

1.
$$\begin{array}{r} 4x + 7 \\ (-) \quad x + 8 \\ \hline \end{array}$$

2.
$$\begin{array}{r} 2x^2 - xy \\ (-) \quad \quad 4xy - 6 \\ \hline \end{array}$$

3. $(6x - y) - (4x + 3y)$

4. $(2x^2 + 5xy - y^2) - (x^2 - 4xy - 2y^2)$

5. The area of a large rectangle is represented by $x^2 + 2x - 15$ square units. The area of a smaller rectangle is represented by $x^2 - 6x + 8$ square units. Find the difference in the areas of the rectangles.

6. **Standardized Test Practice**

The perimeter of the quadrilateral shown is $10x - 4$ units. Find the missing length of the fourth side.

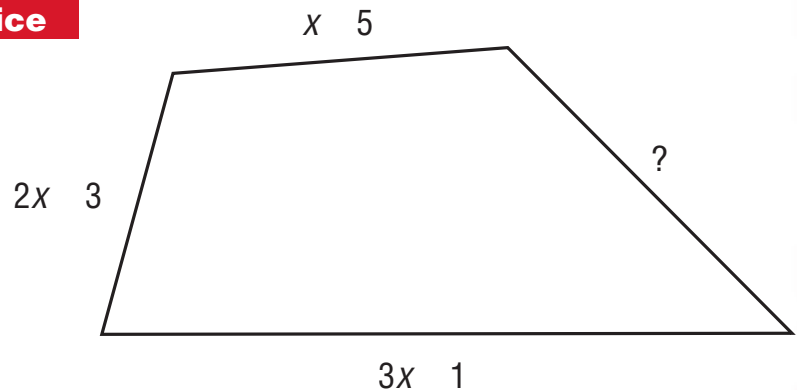

ANSWERS

1. $3x - 1$

2. $2x^2 - 5xy + 6$

3. $2x - 4y$

4. $x^2 + 9xy + y^2$

5. $8x - 23$ square units

6. $4x - 7$



5-Minute Check

(over Lesson 13-4)

Transparency 13-5

Find each product.

1. $8(4x - 3)$

2. $(1 + 2n)5$

3. $4y(y^2 - 8)$

4. $-3a(12a - 5)$

5. The perimeter of a swimming pool is 116 feet. The length is 4 feet more than twice the width. What are the dimensions of the swimmingpool?

6. **Standardized Test Practice** Write an expression for the perimeter of the triangle. Find the value of x if the perimeter is 27 inches.

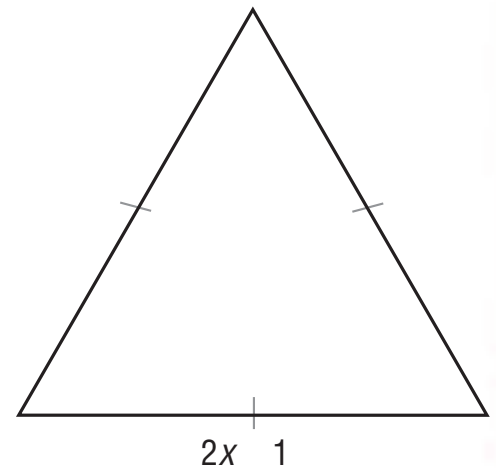

ANSWERS

1. $32x - 24$

2. $5 + 10n$

3. $4y^3 - 32y$

4. $-36a^2 + 15a$

5. 18 feet wide, 40 feet long

6. $6x - 3$; $x = 5$ inches



5-Minute Check

(over Lesson 13-5)

Transparency 13-6

Determine whether each graph, equation, or table represents a *linear* or *nonlinear* function.

1.

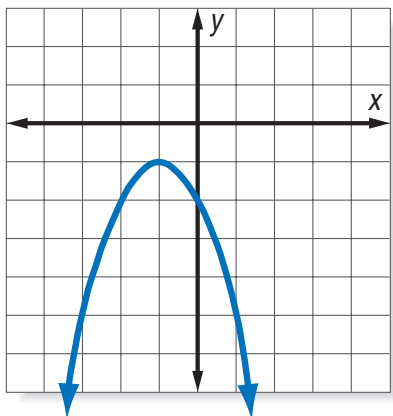

2.

x	y
3	12
6	8
9	4
12	0

3. $3x + y = -10$

4. $y = 2^x$

5. A company found that for every dollar x that they spent on advertising, they had sales y of $600x + 50$ dollars. Is the relationship between dollars spent on advertising and dollars in sales a linear relationship? Explain.

6. **Standardized Test Practice** Which equation does *not* represent a linear function?

(A) $y + \frac{x}{4}$

(B) $x - y = 4$

(C) $xy = 4$

(D) $4x + y = 0$

ANSWERS

1. nonlinear

2. linear

3. linear

4. nonlinear

5. Yes; because it can be written as $y = 600x + 50$.

6. C