

Chapter 14

Resource Masters



Mathematics

Applications and Concepts

Course 1



New York, New York Columbus, Ohio Chicago, Illinois Peoria, Illinois Woodland Hills, California

Consumable Workbooks

Many of the worksheets contained in the Chapter Resource Masters booklets are available as consumable workbooks in both English and Spanish.

<i>Study Guide and Intervention Workbook</i>	0-07-860085-5
<i>Study Guide and Intervention Workbook (Spanish)</i>	0-07-860091-X
<i>Practice: Skills Workbook</i>	0-07-860086-3
<i>Practice: Skills Workbook (Spanish)</i>	0-07-860092-8
<i>Practice: Word Problems Workbook</i>	0-07-860087-1
<i>Practice: Word Problems Workbook (Spanish)</i>	0-07-860093-6
<i>Reading to Learn Mathematics Workbook</i>	0-07-861057-5

Answers for Workbooks The answers for Chapter 14 of these workbooks can be found in the back of this Chapter Resource Masters booklet.

Spanish Assessment Masters Spanish versions of forms 2A and 2C of the Chapter 14 Test are available in the *Glencoe Mathematics: Applications and Concepts Spanish Assessment Masters, Course 1* (0-07-860095-2).

Copyright © by The McGraw-Hill Companies, Inc. All rights reserved.
Printed in the United States of America. Permission is granted to reproduce the material contained herein on the condition that such material be reproduced only for classroom use; be provided to students, teacher, and families without charge; and be used solely in conjunction with *Glencoe Mathematics: Applications and Concepts*, Course 1. Any other reproduction, for use or sale, is prohibited without prior written permission of the publisher.

Send all inquiries to:
Glencoe/McGraw-Hill
8787 Orion Place
Columbus, OH 43240

ISBN: 0-07-860077-4

Mathematics: Applications and Concepts, Course 1
Chapter 14 Resource Masters

1 2 3 4 5 6 7 8 9 10 024 12 11 10 09 08 07 06 05 04 03

CONTENTS

Vocabulary Builder	vii	Lesson 14-5	
Family Letter	ix	Study Guide and Intervention	719
Family Activity	x	Practice: Skills	720
Lesson 14-1		Practice: Word Problems	721
Study Guide and Intervention	699	Reading to Learn Mathematics	722
Practice: Skills	700	Enrichment	723
Practice: Word Problems	701	Lesson 14-6	
Reading to Learn Mathematics	702	Study Guide and Intervention	724
Enrichment	703	Practice: Skills	725
Lesson 14-2		Practice: Word Problems	726
Study Guide and Intervention	704	Reading to Learn Mathematics	727
Practice: Skills	705	Enrichment	728
Practice: Word Problems	706	Chapter 14 Assessment	
Reading to Learn Mathematics	707	Chapter 14 Test, Form 1	729–730
Enrichment	708	Chapter 14 Test, Form 2A	731–732
Lesson 14-3		Chapter 14 Test, Form 2B	733–734
Study Guide and Intervention	709	Chapter 14 Test, Form 2C	735–736
Practice: Skills	710	Chapter 14 Test, Form 2D	737–738
Practice: Word Problems	711	Chapter 14 Test, Form 3	739–740
Reading to Learn Mathematics	712	Chapter 14 Extended Response	
Enrichment	713	Assessment	741
Lesson 14-4		Chapter 14 Vocabulary Test/Review	742
Study Guide and Intervention	714	Chapter 14 Quizzes 1 & 2	743
Practice: Skills	715	Chapter 14 Quizzes 3 & 4	744
Practice: Word Problems	716	Chapter 14 Mid-Chapter Test	745
Reading to Learn Mathematics	717	Chapter 14 Cumulative Review	746
Enrichment	718	Chapter 14 Standardized Test Practice	747–748
		Unit 6 Test/Review	749–750
		Second Semester Test	751–753
		Final Test	755–760
		Standardized Test Practice	
		Student Recording Sheet	A1
		Standardized Test Practice Rubric	A2
		ANSWERS	A3–A33

Teacher's Guide to Using the Chapter 14 Resource Masters

The **Fast File** Chapter Resource system allows you to conveniently file the resources you use most often. The *Chapter 14 Resource Masters* includes the core materials needed for Chapter 14. These materials include worksheets, extensions, and assessment options. The answers for these pages appear at the back of this booklet.

All of the materials found in this booklet are included for viewing and printing in the *Glencoe Mathematics: Applications and Concepts, Course 1, TeacherWorks* CD-ROM.

Vocabulary Builder Pages vii-viii include a student study tool that presents up to twenty of the key vocabulary terms from the chapter. Students are to record definitions and/or examples for each term. You may suggest that students highlight or star the terms with which they are not familiar.

When to Use Give these pages to students before beginning Lesson 14-1. Encourage them to add these pages to their mathematics study notebook. Remind them to add definitions and examples as they complete each lesson.

Family Letter and Family Activity Page ix is a letter to inform your students' families of the requirements of the chapter. The family activity on page x helps them understand how the mathematics students are learning is applicable to real life.

When to Use Give these pages to students to take home before beginning the chapter.

Study Guide and Intervention There is one Study Guide and Intervention master for each lesson in Chapter 14.

When to Use Use these masters as reteaching activities for students who need additional reinforcement. These pages can also be used in conjunction with the Student Edition as an instructional tool for students who have been absent.

Practice: Skills There is one master for each lesson. These provide practice that more closely follows the structure of the Practice and Applications section of the Student Edition exercises.

When to Use These provide additional practice options or may be used as homework for second day teaching of the lesson.

Practice: Word Problems There is one master for each lesson. These provide practice in solving word problems that apply the concepts of the lesson.

When to Use These provide additional practice options or may be used as homework for second day teaching of the lesson.

Reading to Learn Mathematics One master is included for each lesson. The first section of each master asks questions about the opening paragraph of the lesson in the Student Edition. Additional questions ask students to interpret the context of and relationships among terms in the lesson. Finally, students are asked to summarize what they have learned using various representation techniques.

When to Use This master can be used as a study tool when presenting the lesson or as an informal reading assessment after presenting the lesson. It is also a helpful tool for ELL (English Language Learner) students.

Enrichment There is one extension master for each lesson. These activities may extend the concepts in the lesson, offer an historical or multicultural look at the concepts, or widen students' perspectives on the mathematics they are learning. These are not written exclusively for honors students, but are accessible for use with all levels of students.

When to Use These may be used as extra credit, short-term projects, or as activities for days when class periods are shortened.

Assessment Options

The assessment masters in the *Chapter 14 Resources Masters* offer a wide range of assessment tools for intermediate and final assessment. The following lists describe each assessment master and its intended use.

Chapter Assessment

Chapter Tests

- *Form 1* contains multiple-choice questions and is intended for use with basic level students.
- *Forms 2A and 2B* contain multiple-choice questions aimed at the average level student. These tests are similar in format to offer comparable testing situations.
- *Forms 2C and 2D* are composed of free-response questions aimed at the average level student. These tests are similar in format to offer comparable testing situations. Grids with axes are provided for questions assessing graphing skills.
- *Form 3* is an advanced level test with free-response questions. Grids without axes are provided for questions assessing graphing skills.

All of the above tests include a free-response Bonus question.

- The **Extended-Response Assessment** includes performance assessment tasks that are suitable for all students. A scoring rubric is included for evaluation guidelines. Sample answers are provided for assessment.

- A **Vocabulary Test**, suitable for all students, includes a list of the vocabulary words in the chapter and ten questions assessing students' knowledge of those terms. This can also be used in conjunction with one of the chapter tests or as a review worksheet.

Intermediate Assessment

- Four free-response **quizzes** are included to offer assessment at appropriate intervals in the chapter.
- A **Mid-Chapter Test** provides an option to assess the first half of the chapter. It is composed of both multiple-choice and free-response questions.

Continuing Assessment

- The **Cumulative Review** provides students an opportunity to reinforce and retain skills as they proceed through their study of *Glencoe Mathematics: Applications and Concepts, Course 1*. It can also be used as a test. This master includes free-response questions.
- The **Standardized Test Practice** offers continuing review of pre-algebra concepts in various formats, which may appear on the standardized tests that they may encounter. This practice includes multiple-choice, short response, grid-in, and extended response questions. Bubble-in and grid-in answer sections are provided on the master.

Answers

- Page A1 is an answer sheet for the Standardized Test Practice questions that appear in the Student Edition on pages 582–583. This improves students' familiarity with the answer formats they may encounter in test taking.
- Detailed rubrics for assessing the extended response questions on page 583 are provided on page A2.
- The answers for the lesson-by-lesson masters are provided as reduced pages with answers appearing in red.
- Full-size answer keys are provided for the assessment masters in this booklet.

Reading to Learn Mathematics***Vocabulary Builder***

This is an alphabetical list of new vocabulary terms you will learn in Chapter 14. As you study the chapter, complete each term's definition or description. Remember to add the page number where you found the term. Add these pages to your math study notebook to review vocabulary at the end of the chapter.

Vocabulary Term	Found on Page	Definition/Description/Example
base		
center		
cone		
cubic units		
cylinder [SIH-luhn-duhr]		
edge		
face		

Reading to Learn Mathematics**Vocabulary Builder** (continued)

Vocabulary Term	Found on Page	Definition/Description/Example
height		
lateral face		
prism [PRIH-zum]		
pyramid [PEER-ah-MIHD]		
sphere [Sfeer]		
surface area		
three-dimensional figure		
vertex (vertices) [VUHR-tuc-SEEZ]		
volume [VAHL-yoom]		

Family Letter

Dear Parent or Guardian:

We use mathematical skills in many of the things that we do. One of the goals of this class is to show students how the information they are learning in the classroom is relevant to the real world. For example, understanding area and volume is useful in such diverse fields as geography, navigation, sports, and architecture.

In **Chapter 14, Geometry: Measuring Area and Volume**, your child will learn how to find the areas of parallelograms, triangles, and circles. Your child will also explore three-dimensional figures and find the volume and surface area of rectangular prisms. In the study of this chapter, your child will complete a variety of daily classroom assignments and activities and possibly produce a chapter project.

By signing this letter and returning it with your child, you agree to encourage your child by getting involved. Enclosed is an activity that you can do with your child that also relates the math we will be learning in Chapter 14 to the real world. You may also wish to log on to the **Online Study Tools** for self-check quizzes, Parent and Student Study Guide pages, and other study help at www.msmath1.net. If you have any questions or comments, feel free to contact me at school.

Sincerely,

Signature of Parent or Guardian _____ DATE _____

Family Activity

Finding Areas of Triangles

Work with a family member. Find three triangles in your home. For example, you might find triangles on a food container, in a tile pattern, in a wallpaper pattern, or even in a painting. You can also create triangles by drawing the diagonal of a rectangular object. You will need a ruler or tape measure to complete this activity.

1. Describe the first triangle you found. Use a ruler to measure the height and the base of the triangle. Record the measurements.

Height:

Base:

2. The area of a triangle is $\frac{1}{2}$ its base times its height. What is the area of the first triangle?

3. Describe the second triangle you found. Use a ruler to measure the height and the base of the triangle. Record the measurements in the space below.

Height:

Base:

4. What is the area of the second triangle?

5. Describe the third triangle you found. Use a ruler to measure the height and the base of the triangle. Record the measurements in the space below.

Height:

Base:

6. What is the area of the third triangle?

14-1

Study Guide and Intervention

Area of Parallelograms

The area A of a parallelogram is the product of any base b and its height h .

Symbols $A = bh$

Model

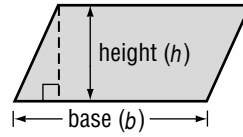

EXAMPLES

Find the area of each parallelogram.

1

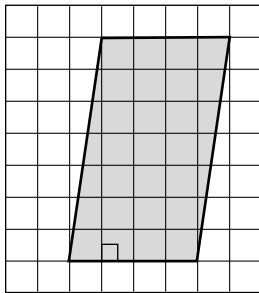

The base is 4 units, and the height is 7 units.

$$A = bh$$

$$A = 4 \times 7$$

$$A = 28$$

The area is 28 square units or 28 units².

2

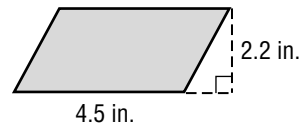

$$A = bh$$

$$A = 4.5 \times 2.2$$

$$A = 9.9$$

The area is 9.9 square inches or 9.9 in².

EXERCISES

Find the area of each parallelogram. Round to the nearest tenth if necessary.

1.

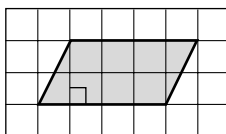

2.

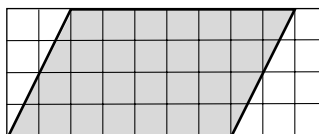

3.

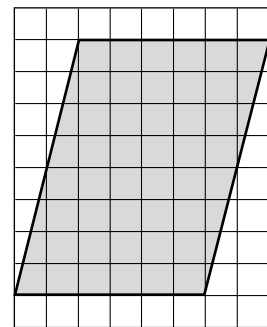

4.

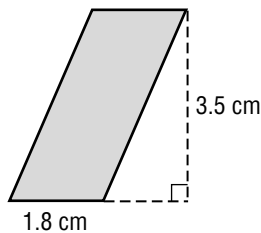

5.

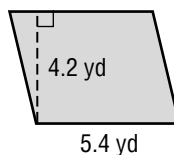

6.

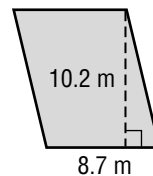

14-1

Practice: Skills

Area of Parallelograms

Find the area of each parallelogram. Round to the nearest tenth if necessary.

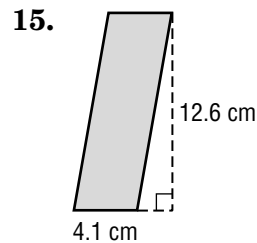
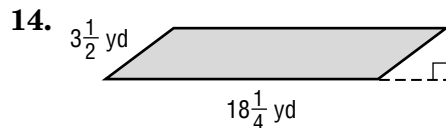
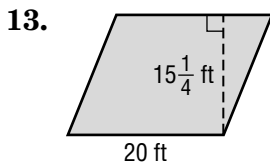
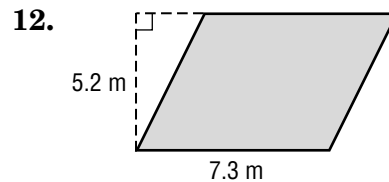
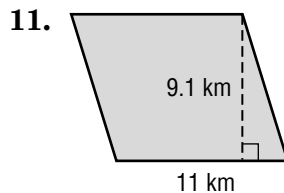
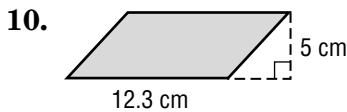
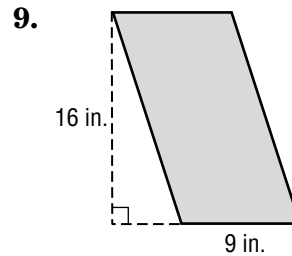
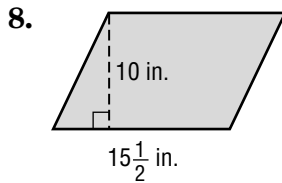
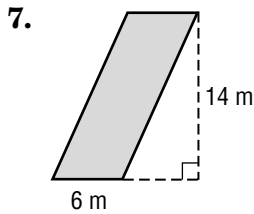
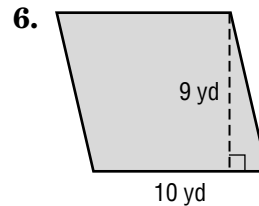
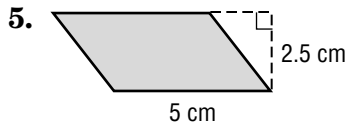
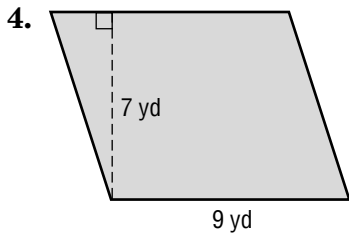
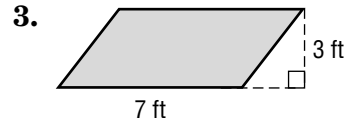
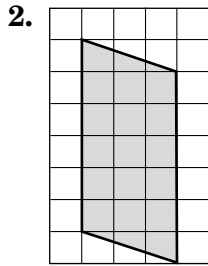
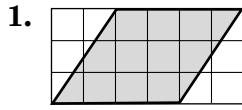

16. What is the measure of the area of a parallelogram with a base of $6\frac{2}{3}$ inches and a height of $1\frac{1}{2}$ inches?

17. Find the area of a parallelogram with base $7\frac{1}{5}$ yards and height $1\frac{1}{9}$ yards.

14-1**Practice: Word Problems****Area of Parallelograms**

- 1. SUNFLOWERS** Norman is a sunflower farmer. His farm is in the shape of a parallelogram with a height measuring 3 kilometers and a base measuring 4.2 kilometers. To the nearest tenth of an acre, what is the total land area Norman uses?

- 2. VOLLEYBALL** Ella and Veronica are in charge of making a banner for the volleyball game this Saturday. How much poster paper will they need for a parallelogram-shaped banner with height $3\frac{1}{2}$ feet and base 6 feet? Explain how you found your answer.

- 3. FLAGS** Joseph is painting the flag of Brunei (a country in Southeast Asia) for a geography project at school. How many square inches will he cover with white paint?

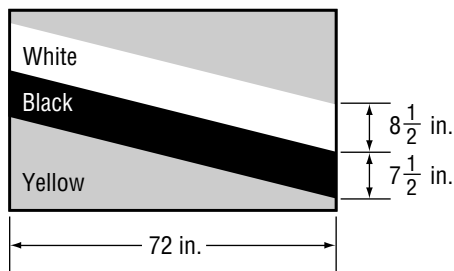

- 4. FLAGS** Use the flag from Exercise 3. How many square inches will Joseph cover with black paint?

- 5. QUILTING** The pattern shows the dimensions of a quilting square that Sydney will use to make a quilt. How much blue fabric will she need? Explain how you found your answer.

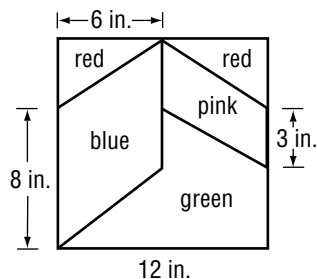

- 6. QUILTING** Use the quilting pattern from Exercise 5. How much pink fabric will Sydney need?

14-1**Reading to Learn Mathematics*****Area of Parallelograms***

Pre-Activity *Complete the Mini Lab at the top of page 546 in your textbook. Write your answers below.*

1. How does a parallelogram relate to a rectangle?
2. What part of the parallelogram corresponds to the length of the rectangle?
3. What part corresponds to the rectangle's width?
4. Write a formula for the area of a parallelogram.

Reading the Lesson

5. Look back at Lesson 1-8, Geometry: Area of Rectangles. Write the definition for the area of a figure.
6. Look at the models in the Mini Lab at the top of page 546 in your textbook. How can you tell from the models that the areas of the rectangle and the parallelogram are the same?
7. Look at Examples 2 and 3 on page 547. Explain what the dotted lines in the figures represent.

Helping You Remember

8. Work with a partner. Using models, demonstrate that the area of a parallelogram equals the product of any base of the parallelogram and its height.

14-1 Enrichment

You Can Count On It!

How many triangles are there in the figure at the right?
How many parallelograms?

When counting shapes in a figure like this, you usually have to think of different sizes.

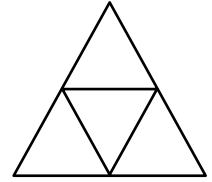

There are four small triangles.

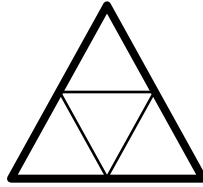

There is one large triangle.

There are five triangles in all.

You also have to think of different positions.

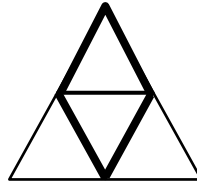
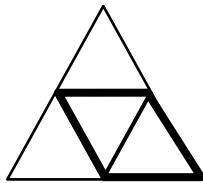
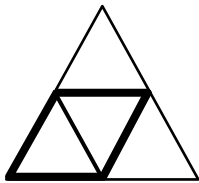

There are three parallelograms in all.

- Now it's your turn. How many triangles are in the figure below?
How many parallelograms? Use the space at the right to organize your counting.

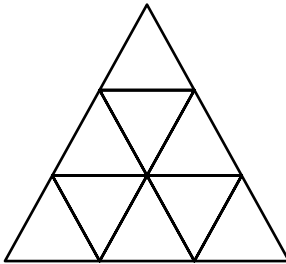

- A trapezoid is a quadrilateral with only one pair of sides parallel, as shown at the right. How many trapezoids are in the figure in Exercise 1?

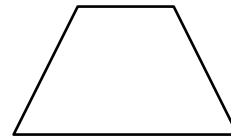

- CHALLENGE** How many triangles, parallelograms, and trapezoids are in the figure at the right?

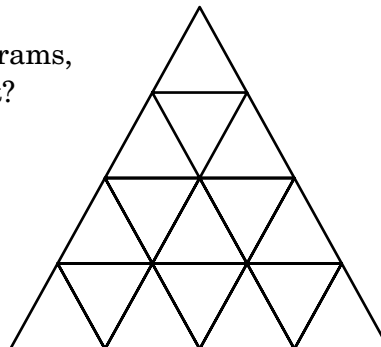

14-2

Study Guide and Intervention

Area of Triangles

The area A of a triangle is one half the product of any base b and its height h .

Symbols $A = \frac{1}{2}bh$

Model

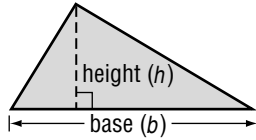

EXAMPLES

Find the area of each triangle.

1

The measure of the base is 5 units, and the height is 8 units.

$$A = \frac{1}{2}bh$$

Area of a triangle

$$A = \frac{1}{2}(5)(8)$$

Replace b with 5 and h with 8.

$$A = \frac{1}{2}(40)$$

Multiply. $5 \times 8 = 40$

$$A = 20$$

The area of the triangle is 20 square units.

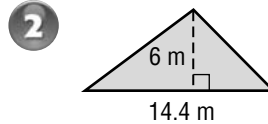

$$A = \frac{1}{2}bh$$

$$A = \frac{1}{2}(14.4)(6)$$

Replace b with 14.4 and h with 6.

0.5 **43.2**

The area of the triangle is 43.2 square meters.

EXERCISES

Find the area of each triangle. Round to the nearest tenth if necessary.

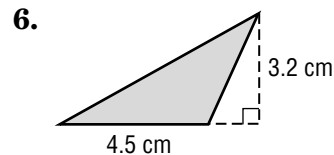
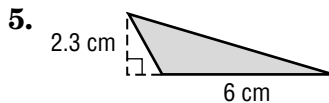
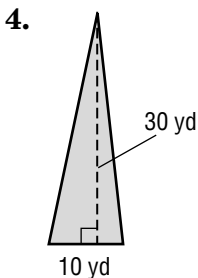
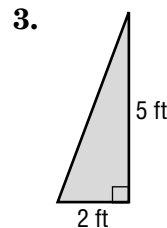
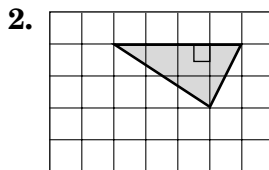
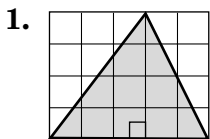

14-2

Practice: Skills

Area of Triangles

Find the area of each triangle. Round to the nearest tenth if necessary.

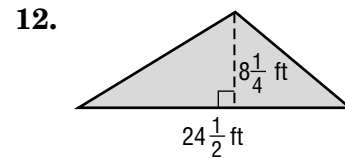
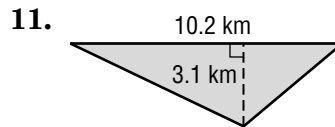
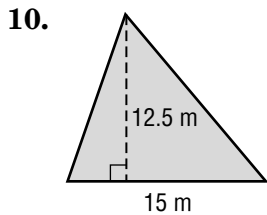
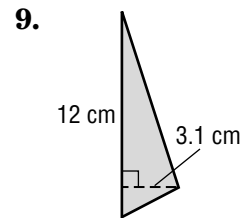
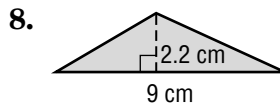
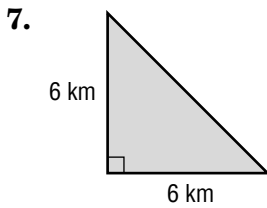
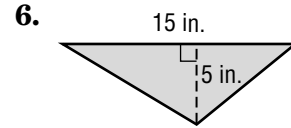
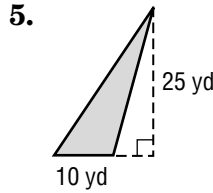
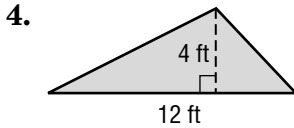
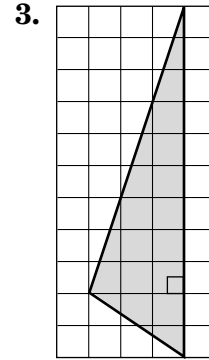
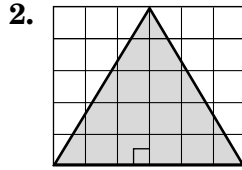
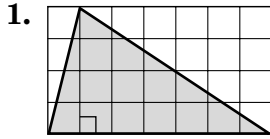

13. base: 4 in.
height: 11 in.

14. base: $4\frac{3}{4}$ yd
height: $1\frac{1}{3}$ yd

15. base: $5\frac{1}{4}$ ft
height: $2\frac{2}{3}$ ft

14-2**Practice: Word Problems****Area of Triangles**

For Exercises 1–6, round to the nearest tenth if necessary.

- 1. CARPETING** Courtney wants to carpet part of her bedroom that is shaped like a right triangle with base 4 meters and height 5.2 meters. How much carpet will she need?

- 2. LAWN** Mrs. Giuntini's lawn is triangle-shaped with a base of 25 feet and a height of 10 feet. What is the area of Mrs. Giuntini's lawn? Explain how you found your answer.

- 3. BUILDING** Norma has an A-frame cabin. The back is shown below. How many square feet of paint will she need to cover the back of the cabin?

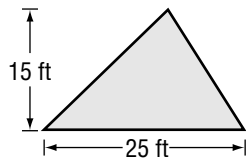

- 4. SNACKS** The dough that will be used to make a pig in a blanket is shown below. Before it is rolled around a sausage, it is brushed with vegetable oil. What is the area that needs to be covered with oil? Explain how you found your answer.

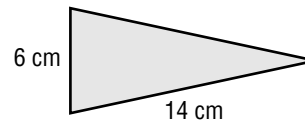

- 5. SAILING** Daniel just bought a used sailboat with two sails that need replacing. How much sail fabric will Daniel need if he replaces sail A?

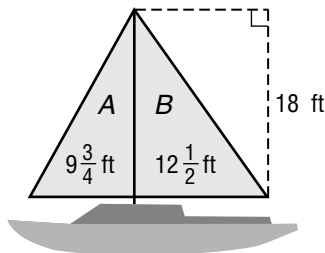

- 6. SAILING** Use the picture from Exercise 5. How much sail fabric will Daniel need if he replaces sail B?

14-2**Reading to Learn Mathematics*****Area of Triangles***

Pre-Activity *Read the introduction at the top of page 551 in your textbook. Write your answers below.*

1. Compare the two triangles.
2. What figure is formed by the two triangles?
3. **Make a conjecture** about the relationship that exists between the area of one triangle and the area of the entire figure.

Reading the Lesson

4. Look at the figure at the right. Explain how the height can be a , b , or d .

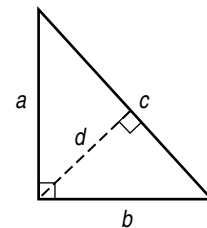

5. Using models, demonstrate that congruent triangles have the same area.
6. Look at the illustrations of h on page 551. What is the symbol found where h and b meet? How does that affect the length of h ?

Helping You Remember

7. Work with a partner. Using models, demonstrate that the area of a triangle is one-half the product of the base b and the height h of the triangle.

14-2

Enrichment

Area of Composite Figures

A **composite figure** is made up, or composed, of other figures. For example, the L-shaped figure at the right is composed of two rectangles. To find the area of the L-shape, find the area of each rectangle, then add.

Area of A

$$A = \ell \times w$$

$$A = 10 \times 6$$

$$A = 60$$

Area of B

$$A = \ell \times w$$

$$A = 20 \times 8$$

$$A = 160$$

So the area of the L-shaped figure is $60 \text{ ft}^2 + 160 \text{ ft}^2$, or 220 ft^2 .

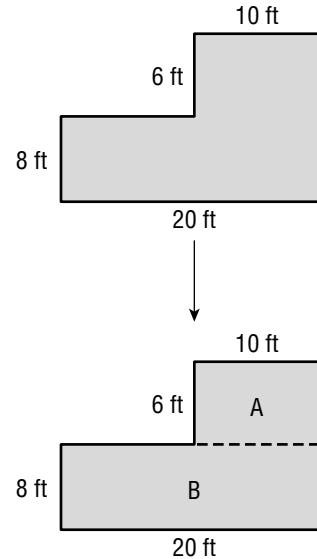

Find the area of each composite figure.

1.

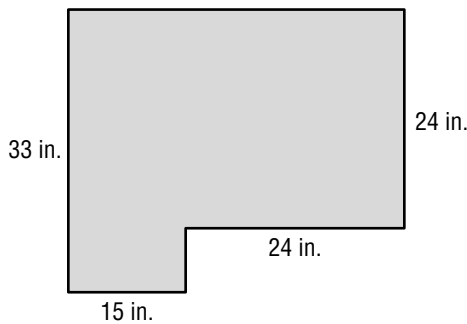

2.

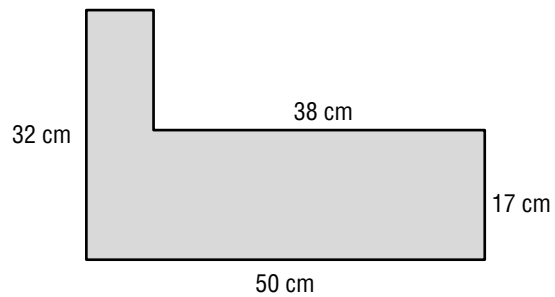

3.

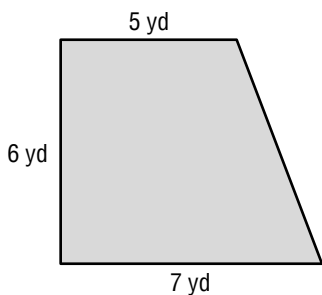

4.

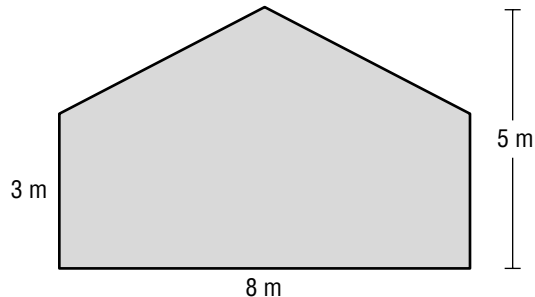

5. **CHALLENGE** Find the area of the shaded region in the figure at the right.

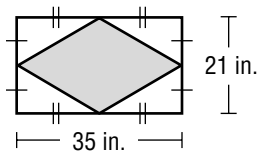

14-3

Study Guide and Intervention

Area of Circles

The area A of a circle is the product of π and the square of the radius r .

Symbols $A = \pi r^2$

Model

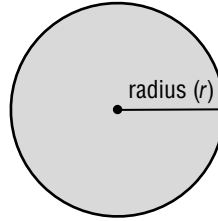

EXAMPLE 1 Find the area of the circle to the nearest tenth.

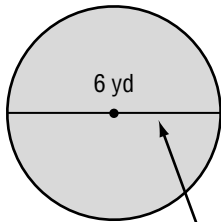

The diameter is 6 yards. So, the radius is $6 \div 2$ or 3 yards.

$$A = \pi r^2$$

Area of a circle

$$A \approx 3.14 \times 3^2$$

Replace π with 3.14 and r with 3.

$$A \approx 3.14 \times 9$$

Evaluate 3^2 .

$$A \approx 28.26$$

Use a calculator.

The area of the circle is about 28.3 square yards.

EXERCISES

Find the area of each circle to the nearest tenth. Use 3.14 for π .

1.

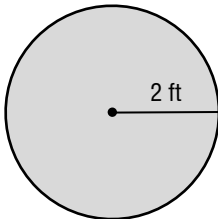

2.

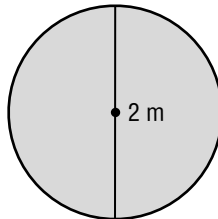

3.

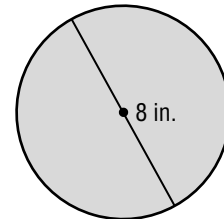

4.

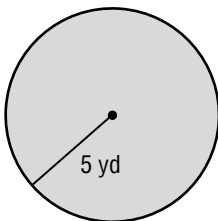

5.

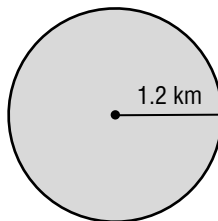

6.

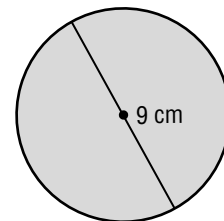

14-3**Practice: Skills****Area of Circles**

Find the area of each circle to the nearest tenth. Use 3.14 for π .

1.

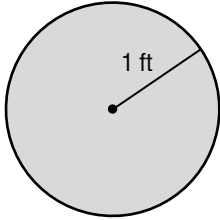

2.

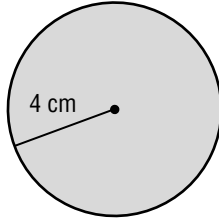

3.

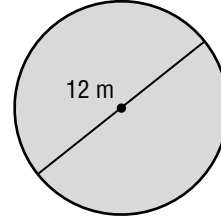

4.

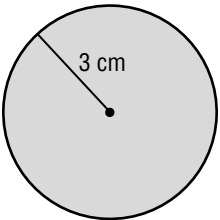

5.

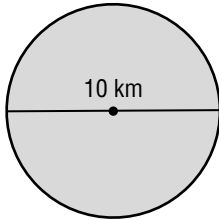

6.

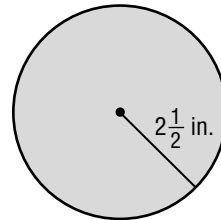

7.

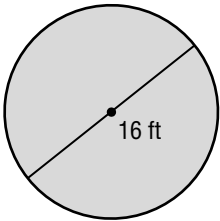

8.

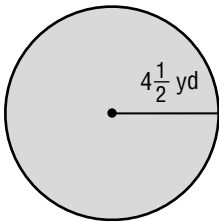

9.

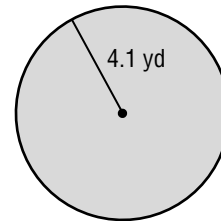

10.

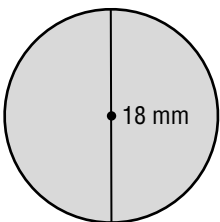

11.

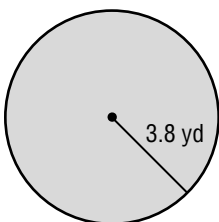

12.

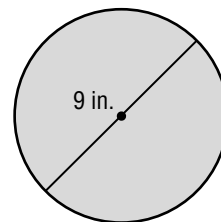

13. What is the area of a circle whose radius is 4.2 yards?

14. Find the area of a circle with a diameter of 13 meters.

15. What is the area of a circle whose radius is 6.6 inches?

14-3

Practice: Word Problems

Area of Circles

For Exercises 1–4, find each area to the nearest tenth. Use 3.14 for π .

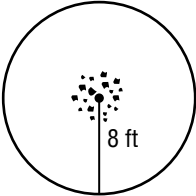
<p>1. SWIMMING POOLS Jensen’s parents put him in charge of ordering a cover for their new swimming pool. The pool is in the shape of a circle and has a radius of 14 feet. What will the area of the cover need to be?</p>	<p>2. BASKETBALL Thompson School will paint the center circle of the basketball court with yellow paint, one of the school colors. The circle has a radius of 2 feet. What is the area that will be painted yellow?</p>
<p>3. BASEBALL The pitcher’s mound on a regulation baseball field has a diameter of 18 feet. What is the area of a pitcher’s mound?</p>	<p>4. CAMPING A group of campers needs to clear away twigs and bark on the ground to make a fire circle for people to safely sit around the campfire. What is the area that they need to clear?</p> 

For Exercises 5 and 6, find each area to the nearest tenth. Use 3.14 for π . Use the following information.

SCIENCE Hal and Frank are conducting a science experiment. They drop a pebble into a pond and measure the radius of the circles of waves.

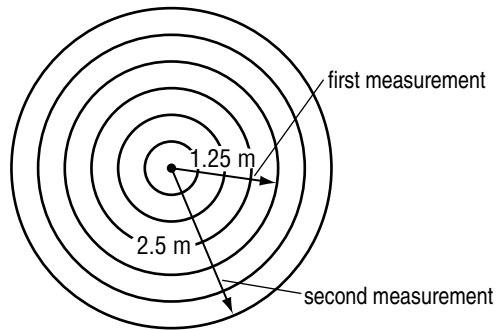

<p>5. What was the area covered by waves the first time it was measured?</p>	<p>6. What was the area covered by waves the second time it was measured? Explain how you found your answer.</p>
---	---

14-3**Reading to Learn Mathematics*****Area of Circles***

Pre-Activity *Complete the Mini Lab at the top of page 556 in your textbook. Write your answers below.*

1. What shape does the figure look like?
2. What part of the circle represents the figure's height?
3. Relate the circle's circumference to the base of the figure.
4. How would you find the area of the figure?

Reading the Lesson

5. The second sentence below the Mini Lab says, "The parts can then be arranged to form a figure that resembles a parallelogram." How is the parallelogram-like figure in the Mini Lab different from a parallelogram?
6. Draw a circle. Label the circumference, radius, and diameter.

Helping You Remember

7. To help yourself practice computing the area of a circle, find a few circular objects such as plates, cups, and tops of cans. Measure each radius or diameter with a ruler and then find the area of the circle.

14-3 Enrichment

Area of Sectors

In the circle at the right, the vertex of $\angle AOB$ is the center of the circle. So, $\angle AOB$ is called a **central angle** of the circle, and the shaded region is a **sector** of the circle. When you know the radius of the circle and the measure of the central angle, it's easy to find the area of the sector.

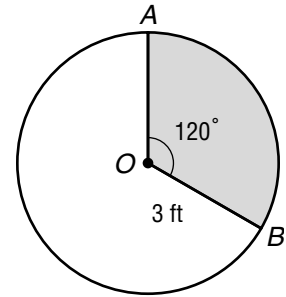

First find the area of the circle.

Then find what fractional part of the circle is in the sector.

$$A = \pi r^2$$

$$A \approx 3.14 \cdot (3)^2$$

$$A \approx 3.14 \cdot 9$$

$$A \approx 28.26$$

$$\begin{aligned} \text{degree measure of central angle} &\rightarrow \frac{120}{360} = \frac{1}{3} \\ \text{degree measure of circle} &\rightarrow \end{aligned}$$

So, the area of the sector is about $\frac{1}{3}$ of 28.26 ft^2 , or about 9.42 ft^2 .

Find the area of each shaded sector. Use 3.14 for π .

1.

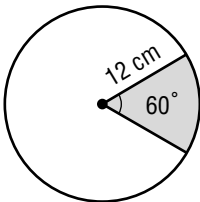

2.

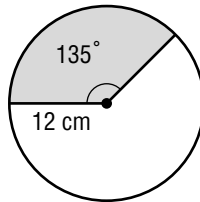

3.

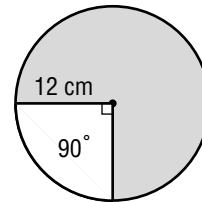

4.

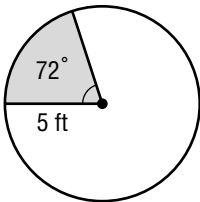

5.

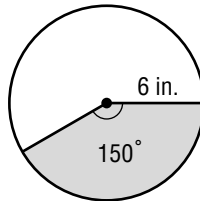

6.

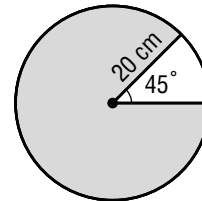

7. **CHALLENGE** In the circle at the right, the shaded region is called a **segment** of the circle. Find the area of the segment.

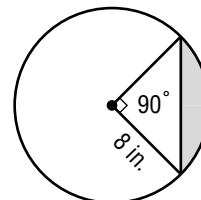

14-4

Study Guide and Intervention

Three-Dimensional Figures

Three-dimensional figures are shapes with length, width, and depth (or height).

Some terms associated with three-dimensional figures are face, edge, vertex, and lateral face.

The polygons that form three-dimensional figures are called **faces**.

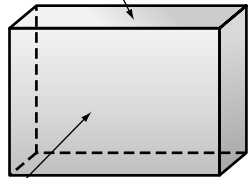

The faces intersect to form **edges**.

The sides are called **lateral faces**.

The edges intersect to form **vertices**.

Prisms have two parallel **bases** and at least three lateral faces that are rectangles.

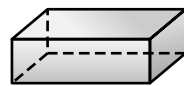

rectangular prism

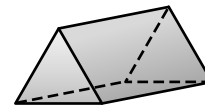

triangular prism

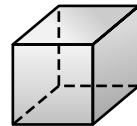

square prism or cube

Pyramids are named by their bases and have at least three lateral faces that are triangles.

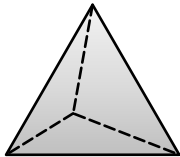

triangular pyramid

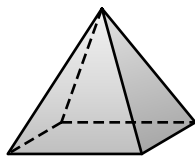

square pyramid

Some three-dimensional figures have curved surfaces and no edges.



cylinder

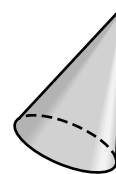

cone

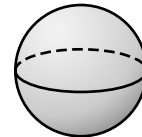

sphere

EXERCISES

Identify each figure.

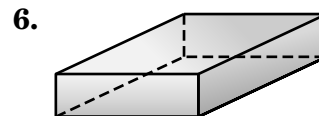
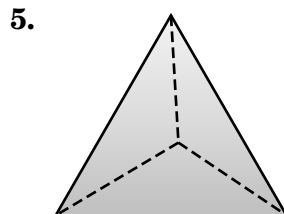
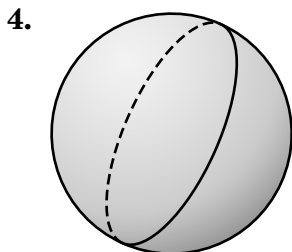
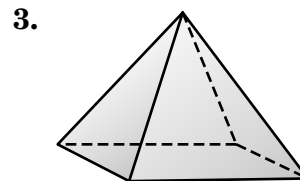
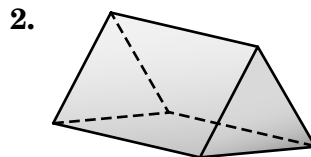
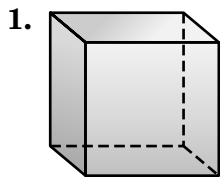

14-4

Practice: Skills

Three-Dimensional Figures

Identify each figure.

1.

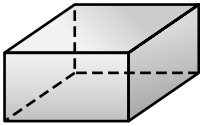

2.

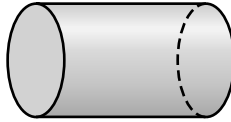

3.

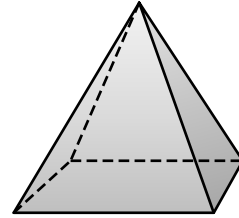

4.

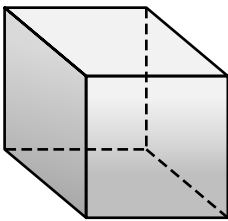

5.

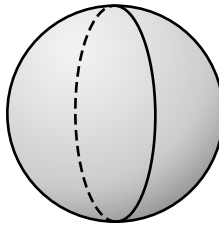

6.

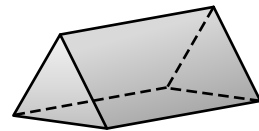

7.

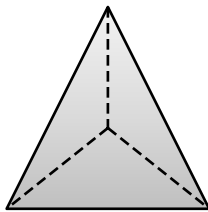

8.

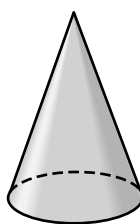

9.

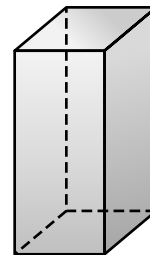

10.

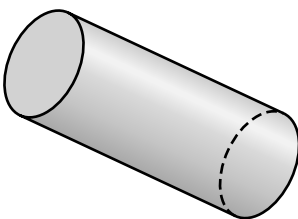

11.

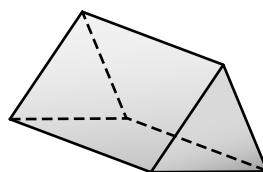

12.

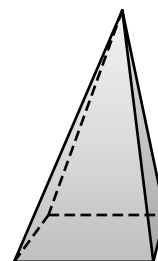

14-4**Practice: Word Problems****Three-Dimensional Figures**

1. TENNIS As professional tennis players, Venus and Serena Williams strike tennis balls with rackets. Draw the figure that represents a tennis ball. What type of figure is this?

2. BACKPACKING Below are pictures of some of the objects Kelly takes with her for backpacking trips. Identify the figure each picture represents.

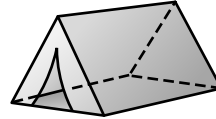

Tent

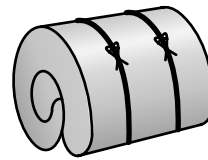

Sleeping Bag

3. MECHANICS A mechanic uses a funnel when he or she puts fluids into cars. What type of figure does a funnel represent? Draw the figure.

4. DESIGN Rachael Johnson is a toy designer. She uses square blocks of wood to make alphabet blocks. Draw and name the figure that an alphabet block represents.

5. FIGURES Alice and Julie were arguing over the name of this figure. What is the name of the figure? How do you know?

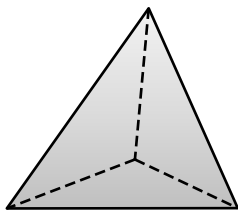

6. CANDLES Kevin arranged several scented candles on his kitchen table before his birthday party started. Use the picture of Kevin's arrangement to name the type of figure each candle represents.

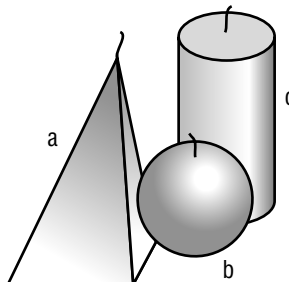

14-4**Reading to Learn Mathematics*****Three-Dimensional Figures***

Pre-Activity *Read the introduction at the top of page 564 in your textbook. Write your answers below.*

1. What shape does the delta kite resemble?
2. Name the shape that each side of the box kite resembles.
3. Describe how the shape of the box kite differs from the shape of the delta kite.

Reading the Lesson

For Exercises 4–11, tell whether each phrase describes a *prism*, *pyramid*, *cone*, *cylinder*, or *sphere*.

- | | |
|---------------|--------------------------------------|
| 4. no faces | 5. curved surface |
| 6. no bases | 7. lateral faces that are rectangles |
| 8. one base | 9. lateral faces that are triangles |
| 10. two bases | 11. one vertex |
12. What determines the name of a prism or pyramid?
13. Compare a triangular pyramid and a square pyramid. How are they similar? How are they different?

Helping You Remember

14. Draw an example of each figure.

prism	pyramid	cone	cylinder	sphere

14-4 Enrichment



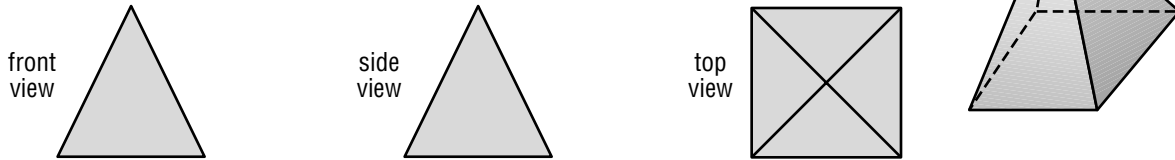

Point of View

At the right is a square pyramid as seen from a point of view that is slightly above and to the right. Here is the same pyramid when you look at it from three different points of view.

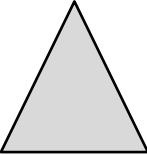
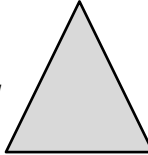
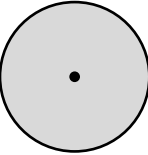

Notice that these views appear two-dimensional. Architects, engineers, and designers often use views like these to provide a detailed description of a three-dimensional object.

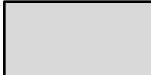
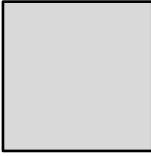
Identify the figure that each set of views represents.

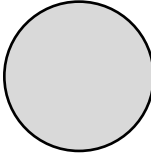
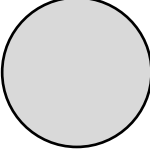
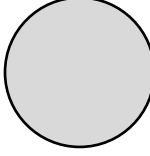
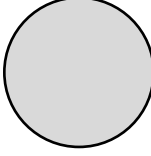
- front view:  side view:  top view: 
- front view:  side view:  top view: 
- front view:  side view:  top view: 
- front view:  side view:  top view: 

5. This figure is called a *truncated cone*. In the space at the right, sketch front, side, and top views of the figure.

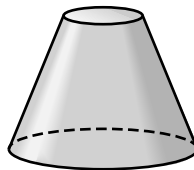

6. **CHALLENGE** At the right, you see three different views of the same cube. What symbol is on the face opposite the plus sign?

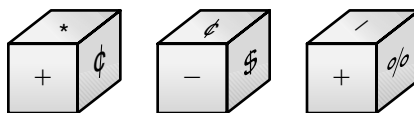

14-5

Study Guide and Intervention

Volume of Rectangular Prisms

The amount of space inside a three-dimensional figure is the **volume** of the figure. Volume is measured in **cubic units**. This tells you the number of cubes of a given size it will take to fill the prism.

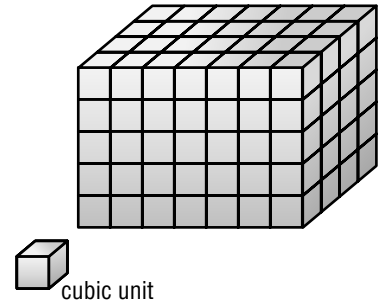

The volume V of a rectangular prism is the product of its length ℓ , width w , and height h .

Symbols $V = \ell wh$

Model

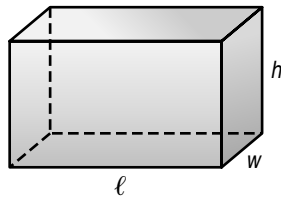

You can also multiply the area of the base B by the height h to find the volume V .

Symbols $V = Bh$

Model

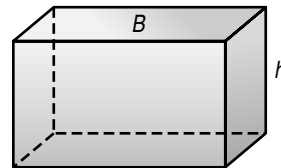

EXAMPLE 1 Find the volume of the rectangular prism.

Method 1 Use $V = \ell wh$.

$$V = \ell wh$$

$$V = 10 \times 5 \times 2$$

$$V = 100$$

The volume is 100 ft^3 .

Method 2 Use $V = Bh$.

$$V = Bh$$

$$V = 50 \times 2 \quad \text{is } 10 \times 5 \text{ or } 50.$$

$$V = 100$$

The volume is 100 ft^3 .

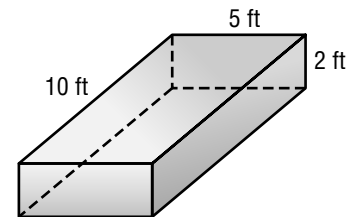

EXERCISES

Find the volume of each figure. Round to the nearest tenth if necessary.

1.

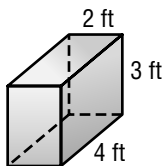

2.

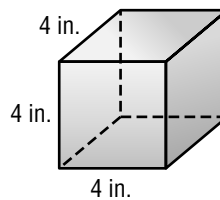

3.

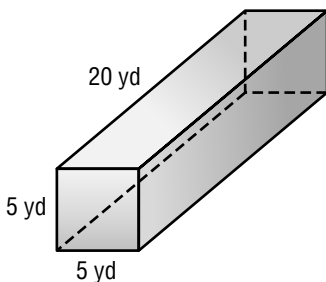

4.

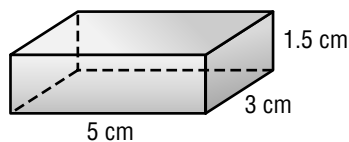

14-5**Practice: Skills*****Volume of Rectangular Prisms***

Find the volume of each rectangular prism. Round to the nearest tenth if necessary.

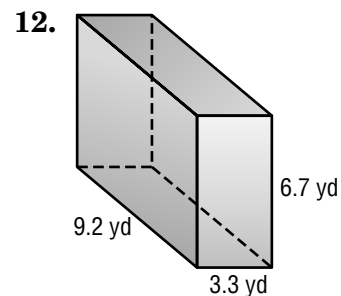
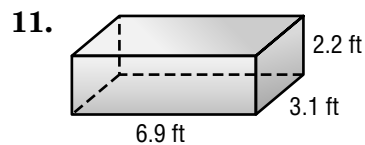
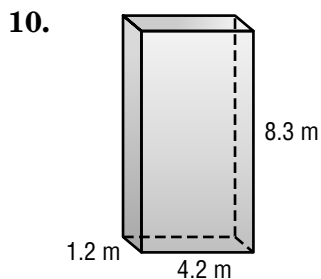
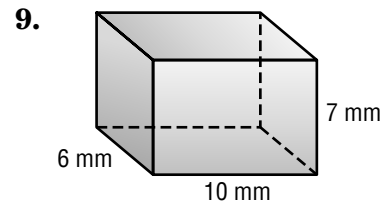
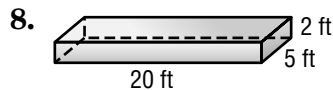
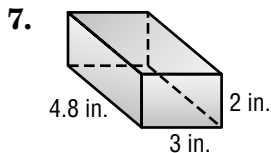
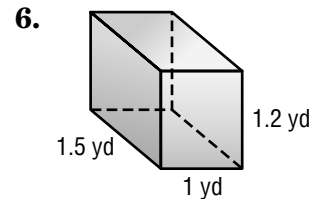
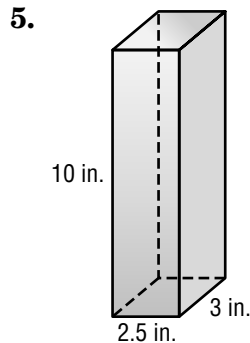
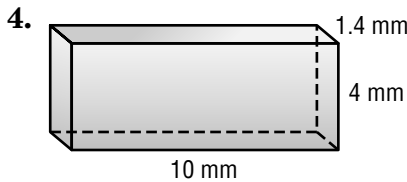
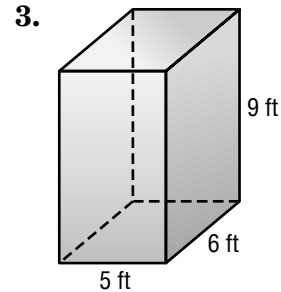
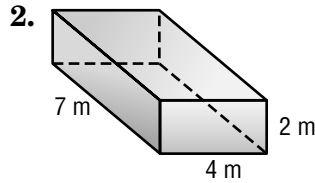
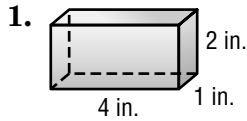

13. Find the volume of a rectangular prism with length 9 meters, width 4 meters, and height 5 meters.

14. What is the volume, to the nearest tenth, of a rectangular prism with length 6.2 yards, width 2.6 yards, and a height of 1.5 yards?

14-5**Practice: Word Problems*****Volume of Rectangular Prisms***

Find the volume to the nearest tenth if necessary.

- 1. OLYMPICS** Olympic gold medal winner Ian Thorp competes in a pool with required dimensions 25 meters by 50 meters by 2 meters. What is the volume of the Olympic-sized pool? Explain how you found your answer.

- 2. DUMP TRUCKS** Raphael drives a standard-sized dump truck. The dimensions of the bed of the truck are length 15 feet, width 8 feet, and height 6 feet. What is the volume of the bed of the dump truck?

- 3. GIFTS** William has some antique bottles. He is going to fill the bottles with bath soap and give them away as gifts. Use the figure to find the volume up to the fill line of a bottle.

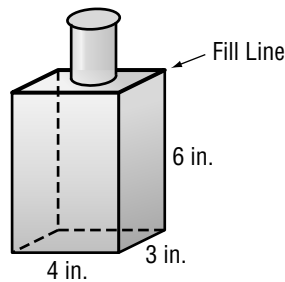

- 4. JEWELRY** Janine keeps her jewelry in a jewelry box like the figure below. Find the volume of Janine's jewelry box.

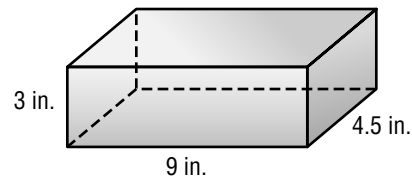

- 5. RECYCLING** The town of Riverview provides a rectangular recycling bin for newspapers to each household. What is the greatest volume of newspapers the recycling bin can hold?

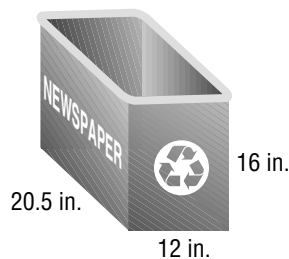

- 6. CANDLE MAKING** Kyle will fill the candle mold with liquid candle wax. Find the amount of liquid wax that will be contained in the mold. Explain how you found your answer.

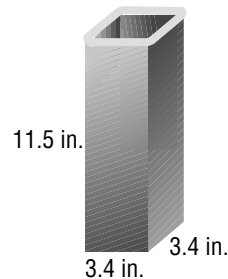

14-5**Reading to Learn Mathematics*****Volume of Rectangular Prisms***

Pre-Activity *Complete the Mini Lab at the top of page 570 in your textbook. Write your answers below.*

1. What are the dimensions of the prism?
2. Estimate how many of each group of cubes it will take to fill the prism. Assume that a group of cubes can be taken apart to fill the prism.
3. Use grid paper and tape to construct the prism. Then use centimeter cubes to find out how many of each group of cubes it will take to fill the prism. Compare the results to your estimates.
4. Describe the relationship between the number of centimeter cubes that it takes to fill the prism and the product of the dimensions of the prism.

Reading the Lesson

Explain what each of the following formulas means.

5. $V = \ell wh$

6. $V = Bh$

Write the unit of measure for volume for each of the following.

7. inch

8. foot

9. centimeter

10. meter

11. Tell how a cubic meter is different from a cubic centimeter.
12. Look at the formula and explanation at the top of page 571. Explain what the phrase rows of cubes means.

Helping You Remember

13. Take the measurements of a box and calculate its volume. Explain your answer.

14-5**Enrichment****Volume and Liquid Capacity**

The volume of a three-dimensional figure is the amount of *space* it contains. Volume is measured in cubic units—cubic meters, cubic inches, and so on.

The liquid capacity of a container is the amount of *liquid* it can hold. Liquid capacity generally is measured in units like liters, milliliters, cups, pints, quarts, and gallons.

The chart at the right shows the relationship between volume and liquid capacity. If a container were shaped like the rectangular prism below the chart, this is how you would find its liquid capacity.

Volume and Liquid Capacity	
Metric	
1 cm ³	= 1 mL
1 m ³	= 1,000 L
Customary	
1 in ³	≈ 0.544 fl oz
1 ft ³	≈ 7.481 gal

Volume

$$V = \ell wh$$

$$V = 7 \times 5 \times 4$$

$$V = 140$$

Liquid Capacity

$$1 \text{ in}^3 \approx 0.544 \text{ fl oz}$$

$$140 \text{ in}^3 \approx (140 \times 0.544) \text{ fl oz}$$

$$140 \text{ in}^3 \approx 76.16 \text{ fl oz}$$

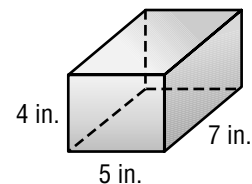

So the liquid capacity of the container is about 76 fluid ounces.

For Exercises 1–4, find the liquid capacity of a container shaped like a rectangular prism with the given dimensions. If necessary, round to the nearest whole number.

1. length, 8 cm
width, 4 cm
height, 6 cm

2. length, 7 ft
width, 2 ft
height, 3 ft

3. length, 3.5 m
width, 1.5 m
height, 5 m

4. length, 5 in.
width, $1\frac{1}{2}$ in.
height, $3\frac{1}{2}$ in.

5. An aquarium is 36 inches long, 18 inches wide, and 18 inches tall. It is filled with water to a height of 12 inches. How many gallons of water are in the aquarium? (Round to the nearest gallon.)

6. **CHALLENGE** How many cubic inches of space are occupied by one quart of water? Round to the nearest whole number.

14-6**Study Guide and Intervention****Surface Area of Rectangular Prisms**

The **surface area** S of a rectangular prism with length ℓ , width w , and height h is the sum of the areas of the faces.

Symbols $S = 2\ell w + 2\ell h + 2wh$

Model

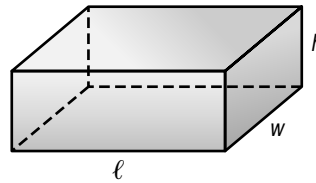
**EXAMPLE 1** Find the surface area of the rectangular prism.

Find the area of each face.

top and bottom

$$2(\ell w) = 2(8 \times 5) = 80$$

front and back

$$2(\ell h) = 2(8 \times 3) = 48$$

two sides

$$2(wh) = 2(5 \times 3) = 30$$

Add to find the surface area. The surface area is $80 + 48 + 30$ or 158 square meters.

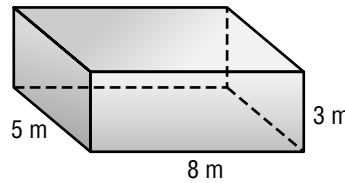
**EXERCISES**

Find the surface area of each rectangular prism. Round to the nearest tenth if necessary.

1.

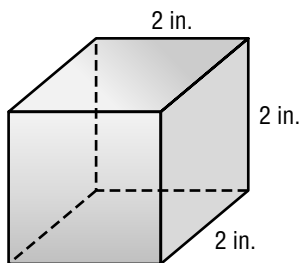

2.

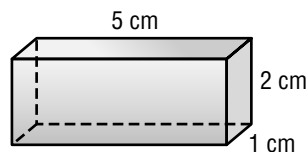

3.

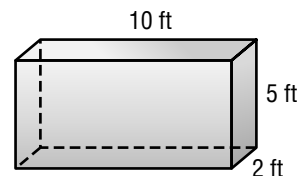

4.

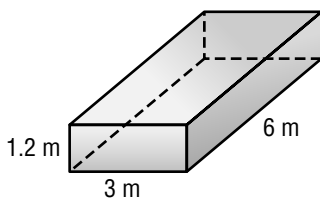

5.

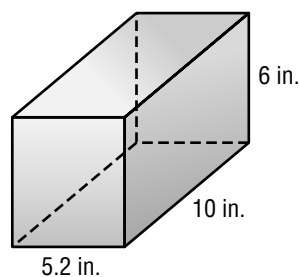

6.

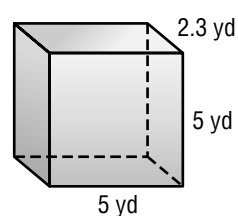

14-6**Practice: Skills****Surface Area of Rectangular Prisms**

Find the surface area of each rectangular prism. Round to the nearest tenth if necessary.

1.

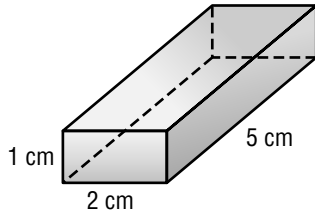

2.

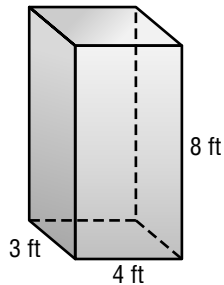

3.

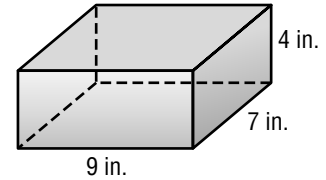

4.

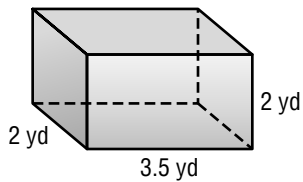

5.

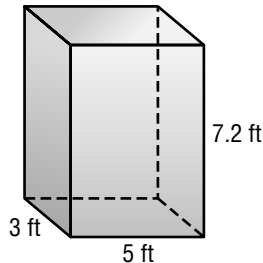

6.

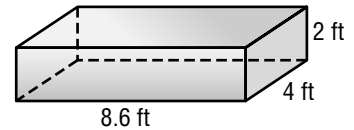

7.

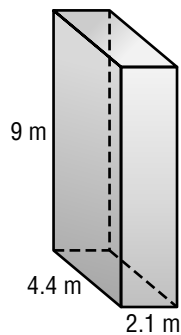

8.

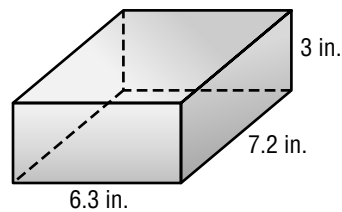

9.

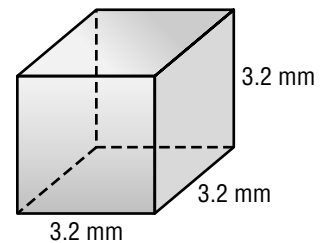

10. Find the surface area of a rectangular prism that is $3\frac{1}{2}$ feet by $4\frac{1}{4}$ feet by 6 feet.

11. What is the surface area of a rectangular prism that measures $2\frac{1}{3}$ meters by $2\frac{1}{2}$ meters by 4 meters?

14-6**Practice: Word Problems****Surface Area of Rectangular Prisms**

For Exercises 1–6, round each surface area to the nearest tenth if necessary.

1. GIFTS Fatima is wrapping a gift box for her nephew's birthday. The box's dimensions are 16 inches long by 10 inches wide by 5 inches high. What is the surface area of the box?

2. FOOD Antoine is wrapping a block of cheese that is 22 centimeters long by 6.5 centimeters high by 10 centimeters wide with plastic wrap. What is the surface area of the cheese block?

3. PAINTING Kyle is painting the front door of his house. The dimensions of the door are 80 inches by 30 inches by 2 inches. If he paints all of the surfaces, how much area will he paint? Explain.

4. CARPENTRY Bryan is sanding a set of speaker boxes that he built for his room. What is the surface area of each box?

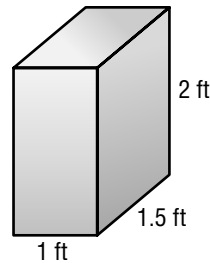

5. CARPENTRY Cindy is putting oak veneer (thin wood covering) on the entire surface of her hope chest. How much veneer will she need?

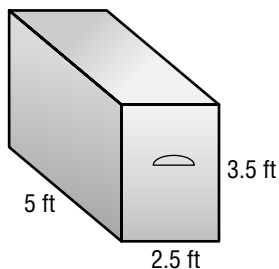

6. TOY MAKING Trey is covering blocks of wood with wallpaper to make building blocks for his baby sister. If he covers all the surfaces, how much wallpaper will he need? Think of a short way to solve this problem and explain.

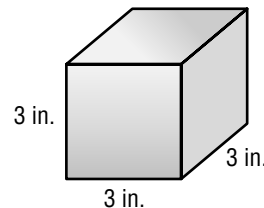

14-6**Reading to Learn Mathematics****Surface Area of Rectangular Prisms**

Pre-Activity Complete the Mini Lab at the top of page 575 in your textbook. Write your answers below.

1. Find the area of each face of the prism.
2. What is the sum of the areas of the faces of the prism?
3. What do you notice about the area of opposite sides of the prism? How could this simplify finding the sum of the areas?

Reading the Lesson

4. Describe in words each step shown for finding the surface area of a rectangular prism.

$$S = 2lw + 2lh + 2wh$$

$$S = 2(17 \times 5) + 2(17 \times 6) + 2(5 \times 6)$$

$$S = 2(85) + 2(102) + 2(30)$$

$$S = 170 + 204 + 60$$

$$S = 434$$

5. What is the unit of measure for surface area?
6. What is the difference between a rectangular prism and a net of the prism?
7. What is the difference between the surface area of a rectangular prism and the volume of the prism?

Helping You Remember

8. Using a net, demonstrate that the surface area of a rectangular prism is equal to $2lw + 2lh + 2wh$.

14-6

Enrichment

Nets

A **net** is a two-dimensional pattern that can be folded to form a three-dimensional figure. For example, the figure at the right is a net for a rectangular prism.

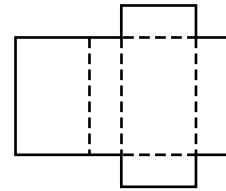

Identify the figure that would be formed by folding each net.

1.

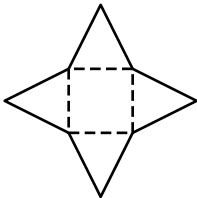

2.

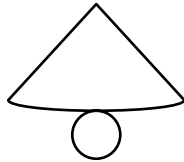

3.

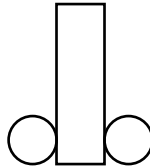

4.

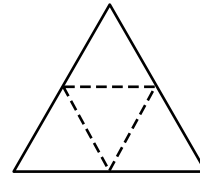

A **cube** is a rectangular prism in which all the edges have the same length. A net for a cube is made up of six squares. However, not every pattern of six squares is a net for a cube. For example, it would be impossible to fold the pattern at the right to form a cube.

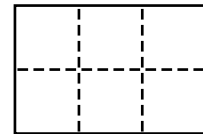

Tell whether each of these patterns is a net for a cube.

5.

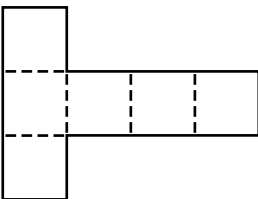

6.



7.

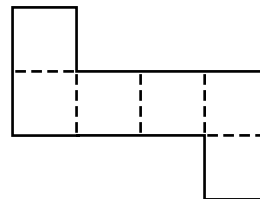

8.

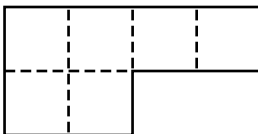

9.

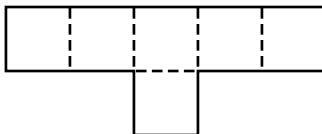

10.

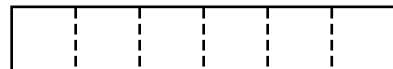

11. **CHALLENGE** In all, there are eleven different patterns of six squares that form a net for a cube. Sketch the eleven patterns in the space below.

Chapter 14 Test, Form 1

Write the letter for the correct answer in the blank at the right of each question.

1. What is the area of the parallelogram shown on the grid?

A. 6 units² B. 8 units²
C. 3 units² D. $5\frac{1}{2}$ units²

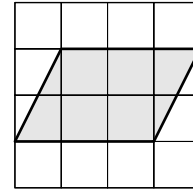

1. _____

2. Find the area of a parallelogram with a base 6 centimeters long and a height of 4 centimeters.

F. 48 cm² G. 24 cm² H. 12 cm² I. 10 cm²

2. _____

3. What is the area of the parallelogram shown at the right?

A. 7.5 ft² B. 8.5 ft²
C. 12 ft² D. 15 ft²

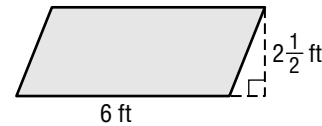

3. _____

4. **ART** Trey draws a parallelogram. The base is 4 inches and the height is 5 inches. What is the area?

F. 4.5 in² G. 9 in² H. 20 in² I. 40 in²

4. _____

5. Find the area of the triangle shown at the right.

A. 12 in² B. 3.5 in²
C. 6 in² D. 7 in²

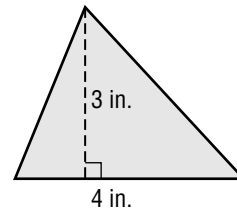

5. _____

6. The base of a triangle is 10 feet and the height is 4 feet. What is the area of the triangle?

F. 40 ft² G. 20 ft² H. 14 ft²

I. 7 ft²

6. _____

7. **GARDENING** A flower bed is in the shape of a triangle, as shown at the right. What is the area of the flower bed?

A. 1 yd² B. 2 yd²
C. 1.5 yd² D. 2.5 yd²

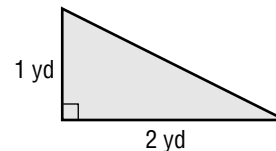

7. _____

For Questions 8–10, find the area of each circle to the nearest tenth.

Use 3.14 for π .

8.

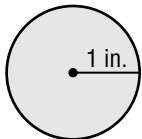

F. 1 in² G. 3.1 in²
H. 4.1 in² I. 6.2 in²

8. _____

9. Find the area of a circle that has a radius of 6 centimeters.

A. 452.2 cm² B. 37.7 cm² C. 36.0 cm² D. 113.0 cm²

9. _____

10.

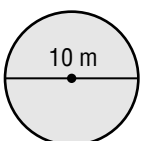

F. 100 m² G. 31.4 m²
H. 314 m² I. 78.5 m²

10. _____

Chapter 14 Test, Form 1 *(continued)*

11. **SCHOOL** A library has a round table whose radius is 3 feet. What is the area of the table top? Round to the nearest tenth. Use 3.14 for π .
- A. 28.3 ft^2 B. 18.8 ft^2 C. 9.0 ft^2 D. 9.4 ft^2 11. _____

12. Identify the figure shown at the right.

F. cone

G. cylinder

H. sphere

I. pyramid

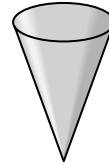

12. _____

13. How many vertices does the figure in Question 12 have?

A. none

B. one

C. two

D. three

13. _____

14. What is the shape of a marble?

F. cylinder

G. sphere

H. circle

I. prism

14. _____

15. Find the volume of the rectangular prism at the right.

A. 25 in^3

B. 30 in^3

C. 10 in^3

D. 15 in^3

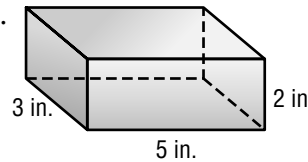

15. _____

16. Which dimensions describe a box that has a volume of 100 cubic feet?

F. 5 ft, 5 ft, 2 ft

G. 5 ft, 5 ft, 4 ft

H. 10 ft, 10 ft, 2 ft

I. 50 ft, 40 ft, 60 ft

16. _____

For Questions 17 and 18, refer to the box at the right.

17. Find the volume of the box.

A. 8 ft^3

B. 7 ft^3

C. 6 ft^3

D. 3 ft^3

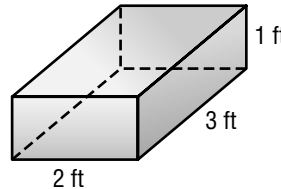

17. _____

18. Find the surface area of the box.

F. 6 ft^2

G. 11 ft^2

H. 18 ft^2

I. 22 ft^2

18. _____

19. What is the surface area of the rectangular prism at the right?

A. 13 cm^2

B. 40 cm^2

C. 76 cm^2

D. 38 cm^2

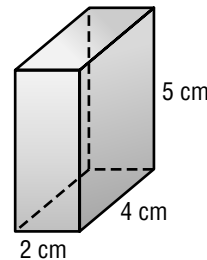

19. _____

20. **CRAFTS** Heidi is painting a small cube. The edges of the cube measure 1 inch. What is the surface area of the cube?

F. 1 in^2

G. 3 in^2

H. 6 in^2

I. 8 in^2

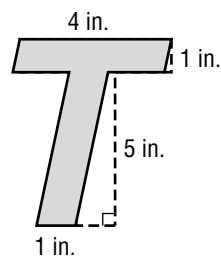

20. _____

Bonus Find the area of the letter shown at the right. (*Hint: Use two parallelograms.*)

B: _____

Chapter 14 Test, Form 2A

Write the letter for the correct answer in the blank at the right of each question.

1. What is the area of the parallelogram at the right?

A. 84 cm^2 B. 168 cm^2
C. 19 cm^2 D. 42 cm^2

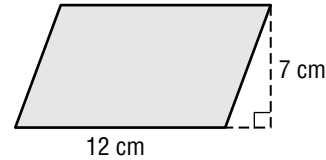

1. _____

2. Find the area of the parallelogram at the right. Round to the nearest tenth if necessary.

F. 10.7 m^2 G. 55.8 m^2
H. 27.9 m^2 I. 14.0 m^2

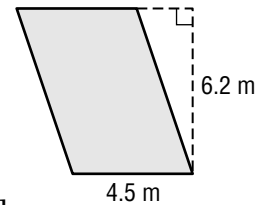

2. _____

3. Find the area of a parallelogram with base $2\frac{1}{4}$ yards and height $4\frac{2}{3}$ yards.

A. $5\frac{1}{4} \text{ yd}^2$ B. 21 yd^2 C. $10\frac{1}{2} \text{ yd}^2$ D. $6\frac{11}{12} \text{ yd}^2$ 3. _____

4. **BOATS** One window in a boat's cabin is the shape of a parallelogram. If the base is 16 inches and the height is 12 inches, what is the window's area?

F. 28 in^2 G. 192 in^2 H. 96 in^2 I. 384 in^2 4. _____

5. Find the area of the triangle at the right.

A. 144 in^2 B. 36 in^2
C. 12.5 in^2 D. 72 in^2

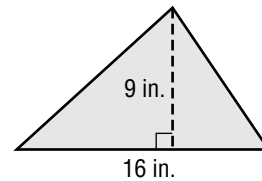

5. _____

6. The base of a triangle is 10.4 feet and the height is 6.5 feet. What is the area of the triangle?

F. 33.8 ft^2 G. 135.2 ft^2 H. 8.5 ft^2 I. 67.6 ft^2 6. _____

7. **SEWING** Lila is making a velvet triangular shawl. The base will be $1\frac{3}{4}$ yards, and the height will be $\frac{2}{3}$ of a yard. How much velvet does she need?

A. $1\frac{5}{24} \text{ yd}^2$ B. $\frac{7}{12} \text{ yd}^2$ C. $\frac{7}{24} \text{ yd}^2$ D. $1\frac{1}{6} \text{ yd}^2$ 7. _____

For Questions 8–10, find the area of each circle to the nearest tenth. Use 3.14 for π .

8.

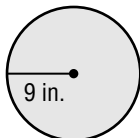

F. $1,017.4 \text{ in}^2$ G. 81.0 in^2
H. 254.3 in^2 I. 56.5 in^2

8. _____

9. Find the area of a circle that has a radius of 6.4 centimeters.

A. 41.0 cm^2 B. 40.2 cm^2 C. 128.6 cm^2 D. 514.5 cm^2 9. _____

10.

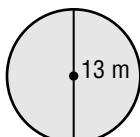

F. 42.3 m^2 G. 132.7 m^2
H. 530.7 m^2 I. 40.1 m^2

10. _____

Chapter 14 Test, Form 2A *(continued)*

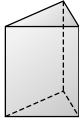
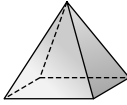
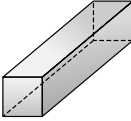
11. **RUGS** Misha has a braided circular rug with a diameter of 8.5 feet in her living room. How much of the floor does it cover? Round to the nearest tenth. Use 3.14 for π .
- A. 18.1 ft^2 B. 226.9 ft^2 C. 26.7 ft^2 D. 56.7 ft^2 11. _____
12. Which figure is a triangular prism?
- F.  G.  H.  I.  12. _____
13. How many vertices does a sphere have?
- A. three B. two C. one D. none 13. _____
14. **MONEY** What is the shape of a nickel?
- F. cylinder G. sphere H. circle I. prism 14. _____
15. Find the volume of the rectangular prism.
- A. 36 yd^3 B. 108 yd^3 C. 63 yd^3 D. 150 yd^3 15. _____
16. **COOKING** Pat has four different size baking pans, with dimensions as shown. Which pan has the least volume?
- F. 9 in. by 16 in. by 1 in. G. 9 in. by 13 in. by 1 in.
H. 9 in. by 9 in. by 2 in. I. 7 in. by 9 in. by $2\frac{1}{2}$ in. 16. _____
17. Which dimensions describe a room that has a volume of 1,800 cubic feet?
- A. 10 ft by 10 ft by 9 ft B. 18 ft by 10 ft by 20 ft
C. 20 ft by 10 ft by 9 ft D. 10 ft by 10 ft by 9 ft 17. _____
18. What is the surface area of the rectangular prism at the right?
- F. 360 cm^2 G. 324 cm^2
H. 162 cm^2 I. 230 cm^2 18. _____
19. Find the surface area of a rectangular prism that measures 2.5 meters by 1.8 meters by 4 meters. Round to the nearest tenth if necessary.
- A. 21.7 m^2 B. 43.4 m^2 C. 25.5 m^2 D. 18.0 m^2 19. _____
20. **PAINTING** A room is 20 feet by 25 feet with a 10-foot ceiling. If Mickey paints the walls and the ceiling, how much surface area will he cover?
- F. $1,800 \text{ ft}^2$ G. $1,400 \text{ ft}^2$ H. 950 ft^2 I. $5,000 \text{ ft}^2$ 20. _____

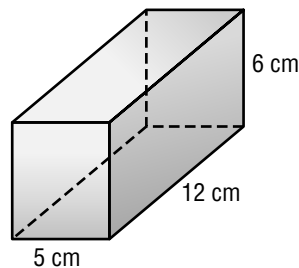
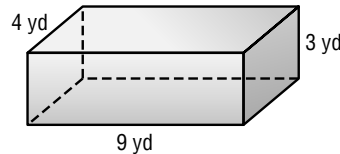

- Bonus GRAPHIC DESIGN** Mandy is designing a large sign that says "THINK!" Use the figure at the right to find the area of the letter H in her sign.

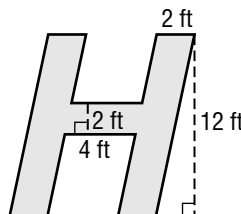

B: _____

Chapter 14 Test, Form 2B

Write the letter for the correct answer in the blank at the right of each question.

1. What is the area of the parallelogram at the right?

A. 20 cm^2
C. 96 cm^2

B. 192 cm^2
D. 48 cm^2

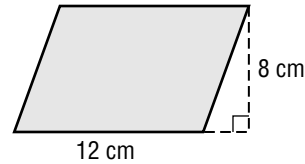

1. _____

2. Find the area of the parallelogram at the right. Round to the nearest tenth if necessary.

F. 21.7 m^2
H. 9.7 m^2

G. 43.4 m^2
I. 10.9 m^2

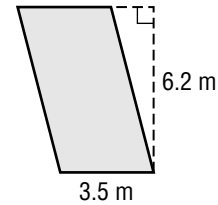

2. _____

3. Find the area of a parallelogram with base $2\frac{1}{4}$ yards and height $7\frac{1}{3}$ yards.

A. $8\frac{1}{4} \text{ yd}^2$

B. 33 yd^2

C. $9\frac{7}{12} \text{ yd}^2$

D. $16\frac{1}{2} \text{ yd}^2$

3. _____

4. **BOATS** One window in a boat's cabin is the shape of a parallelogram. If the base is 14 inches and the height is 12 inches, what is the window's area?

F. 26 in^2

G. 336 in^2

H. 168 in^2

I. 84 in^2

4. _____

5. Find the area of the triangle at the right.

A. 11.5 in^2
C. 112 in^2

B. 56 in^2
D. 28 in^2

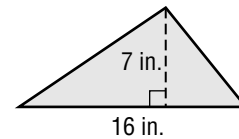

5. _____

6. The base of a triangle is 10.4 feet and the height is 4.5 feet. What is the area of the triangle to the nearest tenth?

F. 93.6 ft^2

G. 46.8 ft^2

H. 7.5 ft^2

I. 23.4 ft^2

6. _____

7. **SEWING** Lila is making a velvet triangular shawl. The base will be $1\frac{2}{3}$ yards, and the height will be $\frac{3}{4}$ yard. How much velvet does she need?

A. $\frac{5}{8} \text{ yd}^2$

B. $1\frac{1}{4} \text{ yd}^2$

C. $\frac{5}{16} \text{ yd}^2$

D. $1\frac{13}{24} \text{ yd}^2$

7. _____

For Questions 8–10, find the area of each circle to the nearest tenth. Use 3.14 for π .

8.

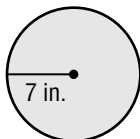

F. 615.4 in^2

G. 44.0 in^2

H. 49.0 in^2

I. 153.9 in^2

8. _____

9. Find the area of a circle that has a radius of 4.6 centimeters.

A. 21.2 cm^2

B. 66.4 cm^2

C. 28.9 cm^2

D. 265.6 cm^2

9. _____

10.

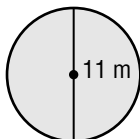

F. 95.0 m^2



G. 34.5 m^2

H. 379.9 m^2

I. 17.3 m^2

10. _____

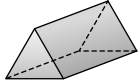
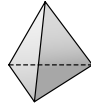
Chapter 14 Test, Form 2B *(continued)*

11. **RUGS** Misha has a braided circular rug with a diameter of 6.5 feet in her living room. How much of the floor does it cover? Round to the nearest tenth. Use 3.14 for π .
- A. 10.6 ft^2 B. 132.7 ft^2 C. 20.4 ft^2 D. 33.2 ft^2 11. _____
12. Which figure is a triangular pyramid?
- F.  G.  H.  I.  12. _____
13. How many vertices does a cylinder have?
- A. none B. one C. two D. three 13. _____
14. **FOOD** What is the shape of an uncooked piece of spaghetti?
- F. cylinder G. sphere H. rectangle I. prism 14. _____
15. Find the volume of the rectangular prism.
- A. 54 yd^3 B. 168 yd^3 C. 108 yd^3 D. 72 yd^3 15. _____
16. **COOKING** Pat has four different size baking pans, with dimensions as shown. Which pan has the largest volume?
- F. 9 in. by 16 in. by 1 in. G. 9 in. by 13 in. by 1 in. I. 7 in. by 9 in. by $1\frac{1}{2}$ in. 16. _____
- H. 9 in. by 9 in. by 2 in.
17. Which dimensions describe a room that has a volume of 1,600 cubic feet?
- A. 10 ft by 8 ft by 10 ft C. 10 ft by 10 ft by 8 ft 17. _____
- B. 16 ft by 10 ft by 20 ft D. 20 ft by 10 ft by 8 ft
18. What is the surface area of the rectangular prism at the right?
- F. 240 cm^2 G. 128 cm^2 I. 185 cm^2 18. _____
- H. 256 cm^2
19. Find the surface area of a rectangular prism that measures 2.5 meters by 1.8 meters by 6 meters. Round to the nearest tenth if necessary.
- A. 45.5 m^2 B. 30.3 m^2 C. 60.6 m^2 D. 27.0 m^2 19. _____
20. **PAINTING** A room is 30 feet by 25 feet and is 10 feet tall. If Mickey paints the walls and the ceiling, how much surface area will he cover?
- F. $1,850 \text{ ft}^2$ G. $1,150 \text{ ft}^2$ H. $2,300 \text{ ft}^2$ I. $7,500 \text{ ft}^2$ 20. _____

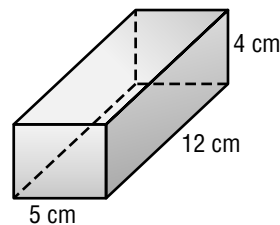
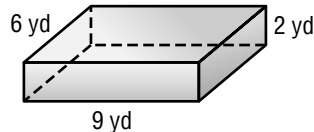

- Bonus GRAPHIC DESIGN** Mandy is designing a large sign that says "THINK!" Use the figure at the right to find the area of the letter I in her sign.

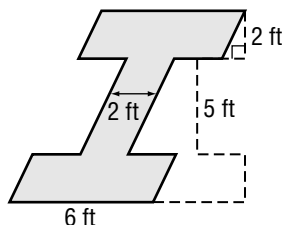

B: _____

Chapter 14 Test, Form 2C

For Questions 1–3, find the area of each parallelogram. Round to the nearest tenth if necessary.

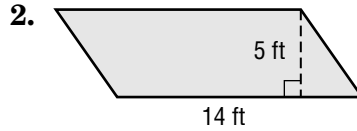
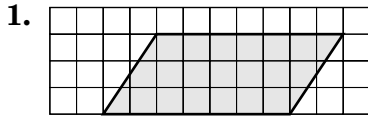

1. _____

2. _____

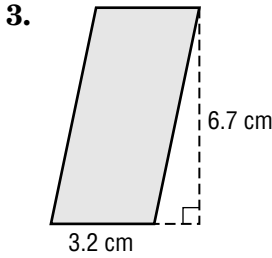

3. _____

4. Find the area of a parallelogram with base $6\frac{2}{3}$ yards and height $5\frac{1}{2}$ yards.

4. _____

For Questions 5 and 6, find the area of each triangle. Round to the nearest tenth if necessary.

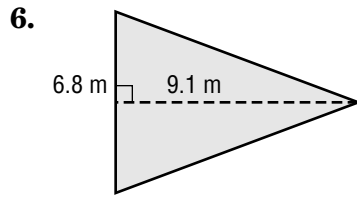
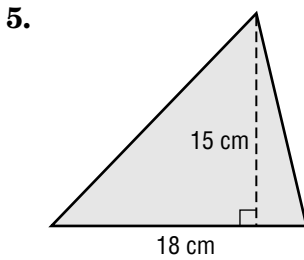

5. _____

6. _____

7. **ART** Alicia is making an abstract painting called “Tangled Triangles” that compares triangles to people. Her idea is to make the triangles look different by using different lengths for the sides, but to make the area the same for all of them. If one triangle has a base of $3\frac{1}{2}$ inches and a height of 12 inches, what is the area of each triangle in the painting?

7. _____

For Questions 8–10, find the area of each circle to the nearest tenth. Use 3.14 for π .

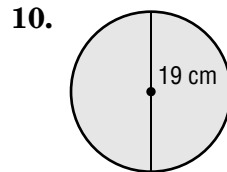
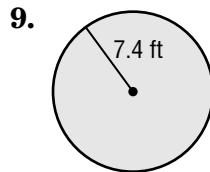
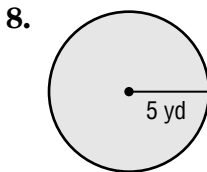

8. _____

9. _____

10. _____

11. **FOOD** What is the area of a paper plate if its diameter is 8 inches? Round to the nearest tenth. Use 3.14 for π .

11. _____

Chapter 14 Test, Form 2C (continued)

For Questions 12 and 13, identify each figure.

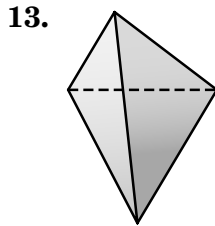
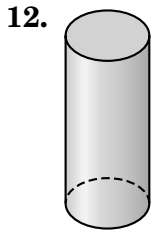

12. _____

13. _____

14. How many vertices does a square prism have?

14. _____

15. Find the volume of the rectangular prism whose sides measure 4 meters, 12 meters, and 7 meters.

15. _____

16. **RECYCLING** Each week, Karen's family saves a stack of newspapers to be recycled. The stack's approximate dimensions are shown at the right. Find the volume of newspaper Karen's family recycles each week.

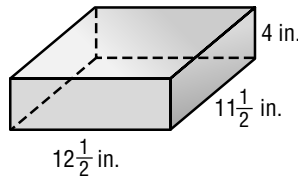

16. _____

Find the surface area of each rectangular prism. Round to the nearest tenth if necessary.

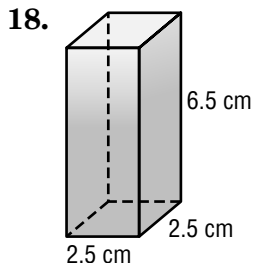
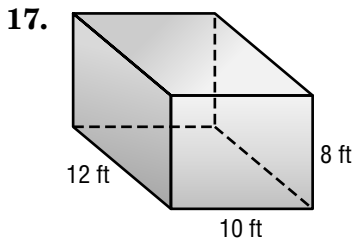

17. _____

18. _____

CAMPING Aaron is going on a camping trip. He has an air mattress that has a length of 6 feet and a width of 3 feet. When filled with air, it inflates to a height of 0.5 feet.

19. What is the volume of air in the inflated mattress?

19. _____

20. Aaron is making a soft cover for the mattress so it is more comfortable. To cover the entire surface area of the inflated mattress, how much fabric will Aaron need?

20. _____

Bonus GRAPHIC DESIGN Misty is designing a large sign that says "FROZEN YOGURT." Use the figure to find the area of the letter N in her sign.

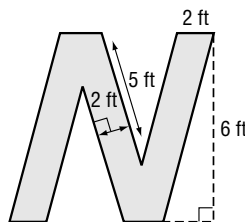

B: _____

Chapter 14 Test, Form 2D

For Questions 1–3, find the area of each parallelogram. Round to the nearest tenth if necessary.

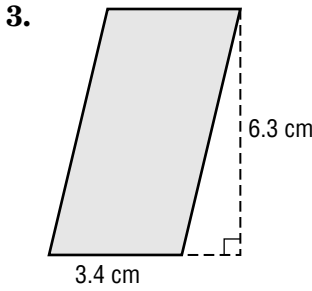
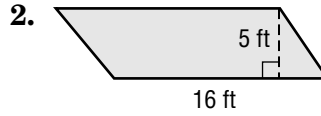
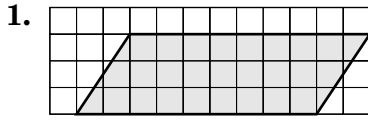

4. Find the area of a parallelogram with base $4\frac{2}{3}$ yards and height $5\frac{1}{2}$ yards.

1. _____

2. _____

3. _____

4. _____

For Questions 5 and 6, find the area of each triangle. Round to the nearest tenth if necessary.

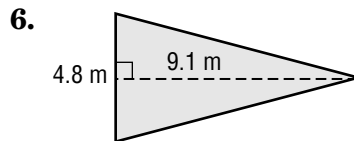
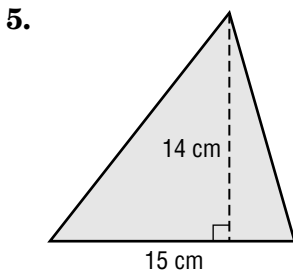

7. **ART** Alan is making an abstract painting called “Tangled Triangles” that compares triangles to people. His idea is to make the triangles look different by using different lengths for the sides, but to make the area the same for all of them. If one triangle has a base of $4\frac{1}{2}$ inches and a height of 12 inches, what is the area of each triangle in the painting?

5. _____

6. _____

7. _____

For Questions 8–10, find the area of each circle to the nearest tenth. Use 3.14 for π .

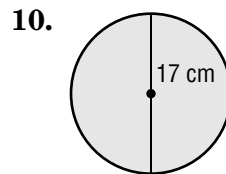
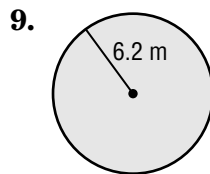
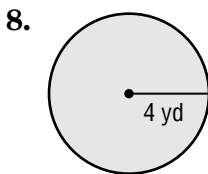

11. **FOOD** What is the area of a paper plate if its diameter is 6 inches? Round to the nearest tenth. Use 3.14 for π .

8. _____

9. _____

10. _____

11. _____

Chapter 14 Test, Form 2D (continued)

For Questions 12 and 13, identify each figure.

12.

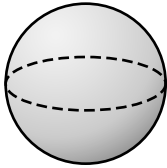

13.

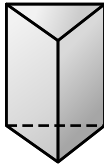

12. _____

13. _____

14. How many faces does a square prism have?

14. _____

15. Find the volume of the rectangular prism whose sides measure 6 meters, 12 meters, and 7 meters.

15. _____

16. **RECYCLING** Each week, Karen's family saves a stack of newspapers to be recycled. The stack's approximate dimensions are shown at the right. Find the volume of newspaper Karen's family recycles each week.

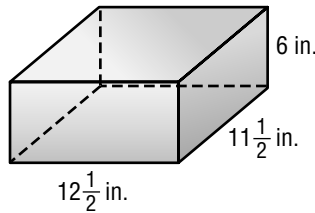

16. _____

Find the surface area of each rectangular prism. Round to the nearest tenth if necessary.

17.

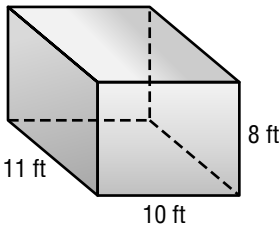

18.

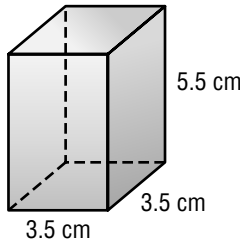

17. _____

18. _____

CAMPING Aaron is going on a camping trip. He has an air mattress that has a length of 6 feet and a width of 4 feet. When filled with air, it inflates to a height of 0.5 feet.

19. What is the volume of air in the inflated mattress?

19. _____

20. Aaron is making a soft cover for the mattress so it is more comfortable. To cover the entire surface area of the inflated mattress, how much fabric will Aaron need?

20. _____

Bonus GRAPHIC DESIGN Misty is designing a large sign that says "FROZEN YOGURT." Use the figure to find the area of the letter Z in her sign.

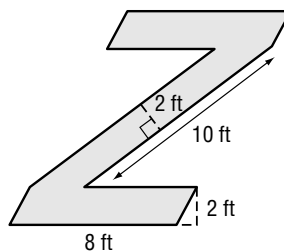

B: _____

Chapter 14 Test, Form 3

For Questions 1 and 2, find the area of each parallelogram. Round to the nearest tenth if necessary.

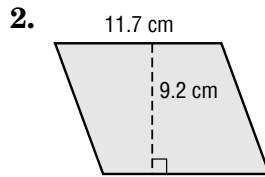
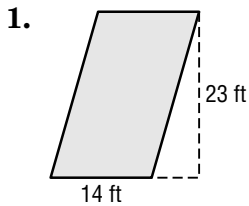

1. _____

2. _____

3. **CONSTRUCTION** Greg is painting a wooden pathway with special paint mixed with sand so it is less slippery. The path connects the sidewalk to the house, as shown in the picture at the right. If w is $\frac{2}{3}$ of a yard and d is $6\frac{3}{8}$ yards, what is the area Greg paints?

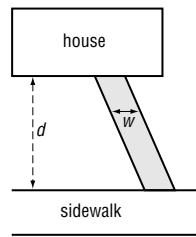

3. _____

For Questions 4 and 5, find the area of each triangle. Round to the nearest tenth if necessary.

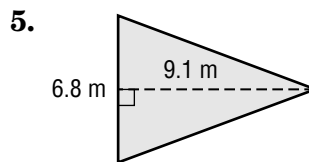
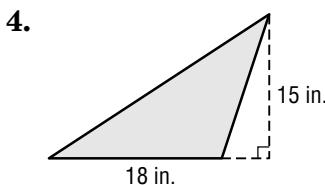

4. _____

5. _____

6. **ART** Alicia is making an abstract painting called “Tangled Triangles” that compares triangles to people. Her idea is to make the triangles look different on the outside by using different lengths for the sides, but to make the area inside the same for each one. One triangle has a base of $3\frac{1}{2}$ inches and a height of 8 inches. If another triangle in the picture has a base of 4 inches, what is its height?

6. _____

For Questions 7–9, find the area of each circle to the nearest tenth. Use 3.14 for π .

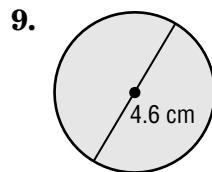
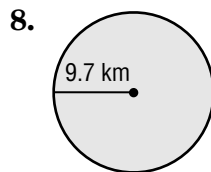
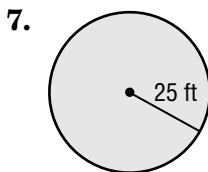

7. _____

8. _____

9. _____

10. **GARDENING** A large circular flower bed has a diameter of $3\frac{5}{8}$ yards. What is the area of the bed? Round to the nearest tenth. Use 3.14 for π .

10. _____

11. Sketch a picture of a new pencil that has just been sharpened. What two figures together could represent the pencil?

11. _____

Chapter 14 Test, Form 3 *(continued)*

12. Draw a picture of a square pyramid. Then tell how many vertices, edges, and faces it has. **12.** _____

13. How many more vertices does a square prism have than a triangular prism? **13.** _____

14. Find the volume of a rectangular prism whose sides measure $4\frac{1}{2}$ yards, $3\frac{1}{8}$ yards, and $2\frac{2}{3}$ yards. **14.** _____

15. **RECYCLING** Kira's family saves a stack of newspapers to be recycled each month. The base of the stack is 11.5 inches by 12.5 inches, the size of a folded newspaper. If the stack's height is an average of 15 inches each month, what is the volume of newspaper Kira's family recycles per year? **15.** _____

16. **SCHOOL** Ben's class collects 24,000 cubic inches of newspaper during their recycling drive. They stack it in a bin that is about 24 inches by 25 inches. How high is the stack? **16.** _____

17. Find the surface area of the rectangular prism at the right. Round to the nearest tenth if necessary.

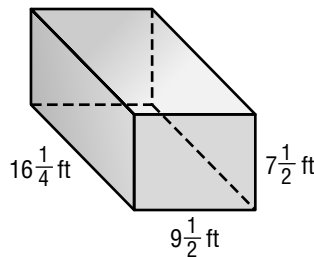

17. _____

18. Find the surface area of a rectangular prism whose sides measure $4\frac{2}{3}$ yards, $5\frac{5}{8}$ yards, and 6 yards. **18.** _____

19. **BIRTHDAYS** Hiram makes a birthday cake as shown at the right. If he frosts the top and the sides of the cake, how much surface area will he cover with frosting?

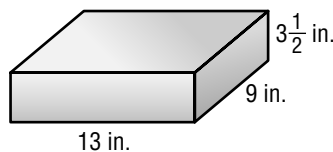

19. _____

20. Determine whether the following statement is true or false, and provide an example (or counterexample) to support your conclusion. *If two figures have the same volume, then they must have the same surface area.* **20.** _____

Bonus FOOD A quart-size box of milk has a rectangular base that measures 2.25 inches by 3.5 inches and is 7.5 inches tall. If a quart is 57.75 cubic inches, how much shorter could the package be and still contain the milk?

B: _____

Chapter 14

Extended Response Assessment

Demonstrate your knowledge by giving a clear, concise solution to each problem. Be sure to include all relevant drawings and justify your answers. You may show your solution in more than one way or investigate beyond the requirements of the problem. If necessary, record your answer on another piece of paper.

1. Ms. Sharp is collecting fabric scraps to make a patchwork quilt. She is cutting parallelograms, triangles, and circles. For each figure, find out how much fabric the shape would use. Show how you found each answer. Use symbols and explain what the symbols mean.

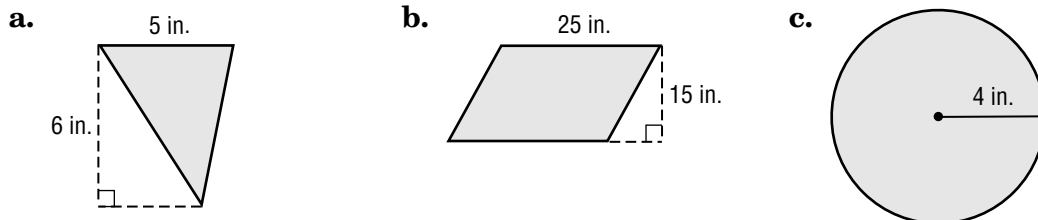

2. Identify each three-dimensional figure. Then write at least two characteristics that help you identify the figure.

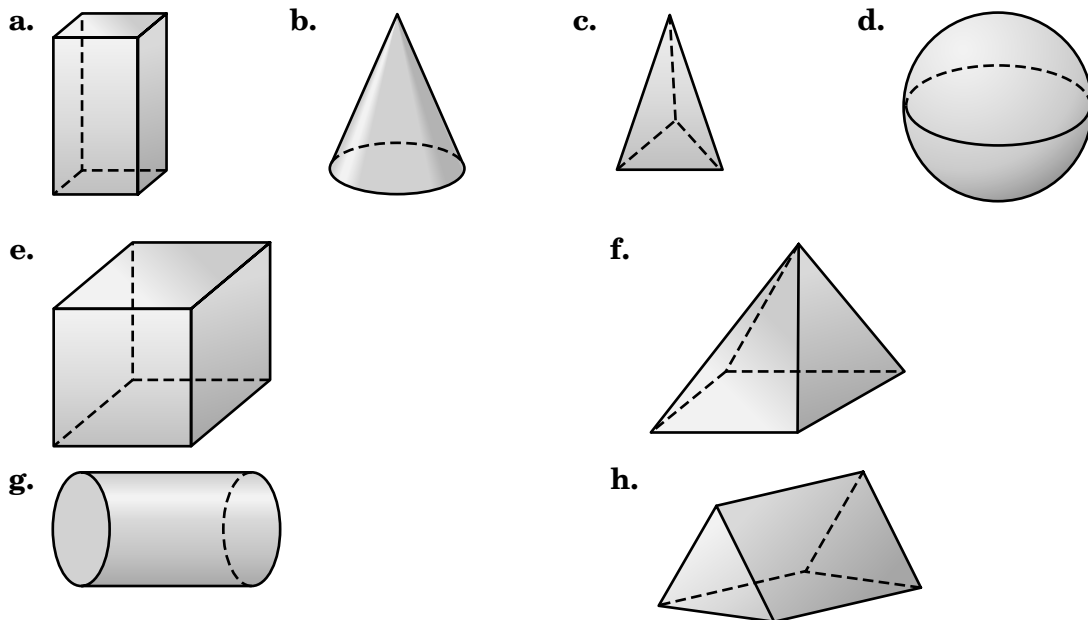

3. Susan is covering a cardboard box with wallpaper to make a gift box to give to her grandmother. She will fill the box with candy she has made. Use the figure to answer the questions.

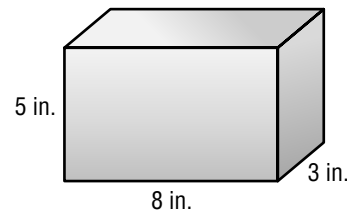

- a. How much wallpaper will Susan need to cover all sides of the box? Show how you found your answer. Use symbols and explain what the symbols mean.
- b. What is the volume of the box? Show how you found your answer. Use symbols and explain what the symbols mean.

Chapter 14 Vocabulary Test/Review

base (pp. 546, 564)
 center (p. 565)
 cone (p. 565)
 cubic units (p. 570)
 cylinder (p. 565)
 edge (p. 564)

face (p. 564)
 height (p. 546)
 lateral face (p. 546)
 prism (p. 564)
 pyramid (p. 564)
 sphere (p. 565)

surface area (p. 575)
 three-dimensional figure (p. 564)
 vertex (vertices) (p. 564)
 volume (p. 570)

Write the letter of the term that best matches each phrase.

- | | |
|--|------------------------|
| _____ 1. a flat surface on a three-dimensional figure | a. volume |
| _____ 2. the amount of space inside a three-dimensional figure | b. prism |
| _____ 3. a three-dimensional figure that has only one vertex | c. cylinder |
| _____ 4. any one of the sides of a parallelogram | d. sphere |
| _____ 5. a three-dimensional figure that has at least three lateral faces that are rectangles and two bases (top and bottom) that are parallel | e. surface area |
| _____ 6. units of measure for volume | f. face |
| _____ 7. the segment formed by two intersecting faces | g. cubic units |
| _____ 8. a three-dimensional figure that has a curved surface on which any point is the same distance from a center | h. cone |
| _____ 9. the sum of the areas of all of the surfaces of a three-dimensional figure | i. base |
| _____ 10. a three-dimensional figure that has two congruent, parallel circles as bases | j. edge |
| _____ 11. In your own words, define the term pyramid. | |

Chapter 14 Quiz

(Lessons 14-1 and 14-2)

For Questions 1 and 2, find the area of each parallelogram. Round to the nearest tenth if necessary.

1.

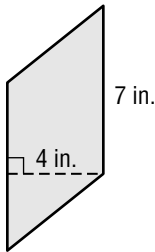

2.

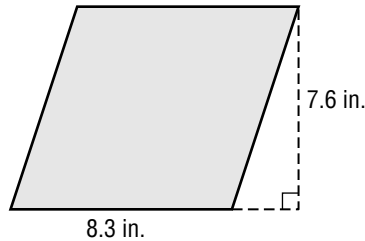

1. _____

2. _____

3. Find the area of a parallelogram with base $2\frac{3}{4}$ yards and height $5\frac{1}{2}$ yards.

3. _____

4. **FOOD** A small company is manufacturing triangular plates for individual slices of pizza. For each plate, the base of the triangle is 9 inches and the height is 12 inches. What is the area of the plate?

4. _____

5. **MULTIPLE-CHOICE TEST ITEM** Which ratio compares the area of the shaded triangle to the area of the large square?

- A. 1 to 4 B. 1 to 8
C. 1 to 16 D. 1 to 32

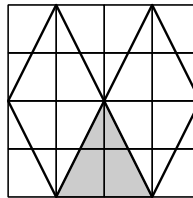

5. _____

Chapter 14 Quiz

(Lesson 14-3)

Find the area of each circle to the nearest tenth. Use 3.14 for π .

1.

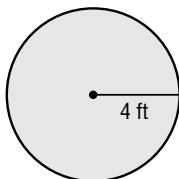

2.

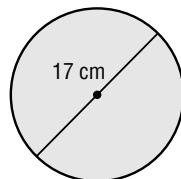

3.

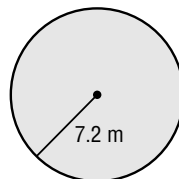

1. _____

2. _____

3. _____

4. **ART** Suzette's painting has a circular canvas. If the diameter of the painting is 1.6 meters, what is the total area of the canvas?

4. _____

5. **SOUND** On a still day, the noon whistle from a small firehouse can be heard anywhere within a 5 mile radius. What is the area of the region where the whistle can be heard?

5. _____

Chapter 14 Quiz

(Lessons 14-4 and 14-5)

For Questions 1 and 2, identify each figure.

1.

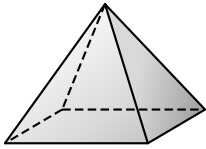

2.

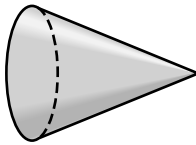

1. _____

2. _____

3. Describe a real object that can be represented by a cylinder.

3. _____

4. Find the volume of the rectangular prism whose sides measure 4 inches, 6 inches, and 7 inches.

4. _____

5. **FOOD** Jian is making juice from concentrate. When mixed with water, it makes 48 ounces of juice, or about 86.63 cubic inches. Will it fit in the container shown at the right? Explain.

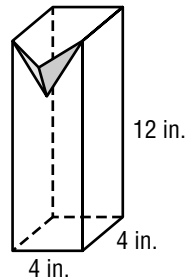

5. _____

Chapter 14 Quiz

(Lesson 14-6)

For Questions 1 and 2, find the surface area of each rectangular prism. Round to the nearest tenth if necessary.

1.

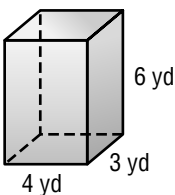

2.

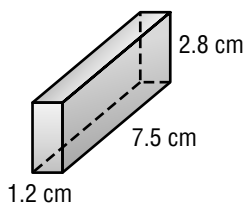

1. _____

2. _____

3. Find the surface area of a cube with sides of 3 inches.

3. _____

4. **MUSIC** A small soundproof room at a recording studio is 10 feet by 12 feet and is 8 feet tall. Everything but the ceiling is to be carpeted to help the room's acoustics. The ceiling will be covered separately with special ceiling tiles. How much carpet is needed for the walls and floor?

4. _____

5. **GIFTS** Wendy is wrapping a present for her brother. She puts it in a box that is 2 feet by 2 feet by 0.5 feet. To wrap it, she glues a different kind of wrapping paper on each face of the box. How much paper does she need to cover the surface if none of the pieces overlap?

5. _____

Chapter 14 Mid-Chapter Test

(Lessons 14-1 through 14-3)

PART I

Write the letter for the correct answer at the right of each question.

1. What is the area of the parallelogram at the right?

- A. 12 in^2 B. 16 in^2
C. 32 in^2 D. 64 in^2

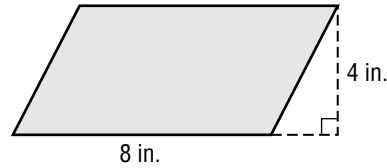

1. _____

2. **QUILTS** Sienna is making a quilt. Each triangular patch has a base of $4\frac{1}{4}$ inches and a height of about 6 inches. How much material will she use for each triangle?

- F. $25\frac{1}{2} \text{ in}^2$ G. $6\frac{3}{8} \text{ in}^2$ H. $5\frac{1}{8} \text{ in}^2$ I. $12\frac{3}{4} \text{ in}^2$

2. _____

3. **MUSIC** A small FM radio station has a signal that can be heard anywhere within a 40 mile radius. What is the station's broadcast area? Use 3.14 for π .

- A. 125.6 mi^2 B. $5,024 \text{ mi}^2$ C. 251.2 mi^2 D. $1,600 \text{ mi}^2$

3. _____

PART II

Find the area of each parallelogram. Round to the nearest tenth if necessary.

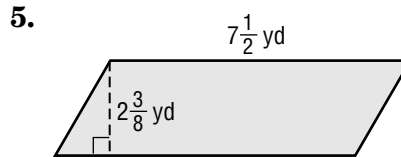
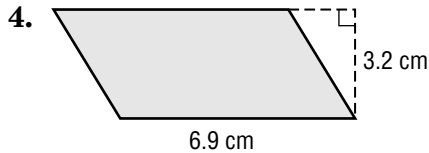

4. _____

5. _____

Find the area of each triangle. Round to the nearest tenth if necessary.

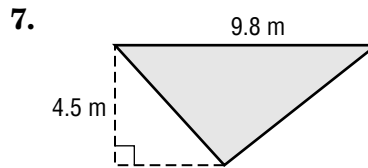
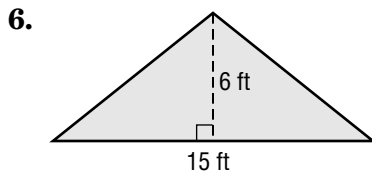

6. _____

7. _____

Find the area of each circle to the nearest tenth. Use 3.14 for π .

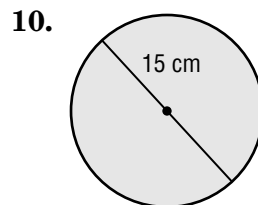
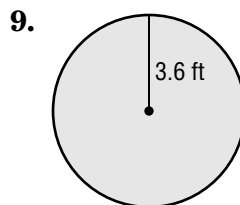
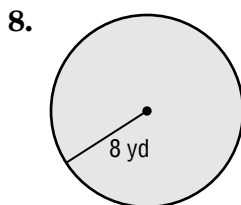

8. _____

9. _____

10. _____

Chapter 14 Cumulative Review

(Chapters 1–14)

- Find the prime factorization of 126. (Lesson 1-3) 1. _____
- What is the mode of 9, 10, 18, 10, 12, and 12? (Lesson 2-7) 2. _____
- Find $103.27 \div 4.6$. (Lesson 4-4) 3. _____
- FOOD** In one class, 8 out of 24 students preferred mustard to ketchup. Express this fraction in simplest form. (Lesson 5-2) 4. _____
- Find $8\frac{3}{10} - 4\frac{3}{4}$. Write in simplest form. (Lesson 6-6) 5. _____
- Find $27 \div 1\frac{1}{2}$. Write in simplest form. (Lesson 7-5) 6. _____

- Make a function table for the graph. Then determine the function rule. (Lesson 9-7)

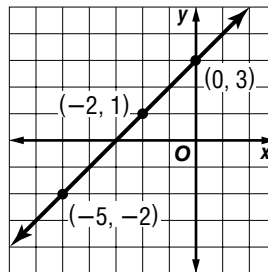

7. _____

- Estimate 51% of 606. (Lesson 10-8) 8. _____
- Write the metric unit of length that you would use to measure the height of a building. (Lesson 12-3) 9. _____
- Angles V and W are complementary. What is $m\angle V$ if $m\angle W = 22^\circ$? (Lesson 13-1) 10. _____

- Draw all lines of symmetry in the figure in the answer column. (Lesson 13-5)

11.

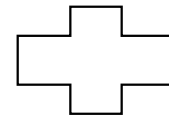

- Find the probability that a randomly thrown dart will land in a shaded region of the dartboard shown. (Lessons 11-4 and 14-2)

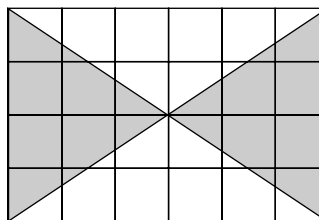

12. _____

- SEWING** Kim is making a round tablecloth that has a diameter of 60 inches. How much fabric does she need? (Lesson 14-3)

13. _____

- Find the surface area of the prism shown. (Lesson 14-5)

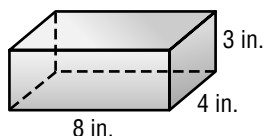

14. _____

Standardized Test Practice

(Chapters 1–14)

Part 1: Multiple Choice

Instructions: Fill in the appropriate oval for the best answer.

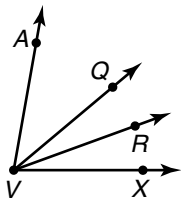
1. Which list of fractions is in order from greatest to least?
(Lesson 5-5)
A. $\frac{1}{3}, \frac{2}{5}, \frac{3}{8}$ B. $\frac{2}{5}, \frac{1}{3}, \frac{3}{8}$ C. $\frac{2}{5}, \frac{3}{8}, \frac{1}{3}$ D. $\frac{1}{3}, \frac{3}{8}, \frac{2}{5}$ 1. (A) (B) (C) (D)
2. The base of a building is at an elevation of 20 feet below sea level. If the building is 58 feet tall, what is the elevation of the roof relative to sea level? (Lesson 8-2)
F. 78 feet G. 38 feet H. -38 feet I. -78 feet 2. (F) (G) (H) (I)
3. What is the value of c if $-35 \div c = -7$? (Lesson 8-5)
A. 7 B. -5 C. 5 D. 0 3. (A) (B) (C) (D)
4. Which is the output for the input -2 using the rule $y = 4x + 2$?
(Lesson 9-6)
F. -10 G. -6 H. 10 I. 0 4. (F) (G) (H) (I)
5. Which percent is greater than 0.6? (Lesson 10-6)
A. 59% B. 0.65% C. 6.0% D. 62% 5. (A) (B) (C) (D)
6. A drawing of the Great Sphinx of Egypt has a scale of 1 inch = 3 meters. What is the actual height of the Great Sphinx if the height on the drawing is 6.7 inches? (Lesson 10-3)
F. 20.1 m G. 2.23 m H. 28 m I. 201 m 6. (F) (G) (H) (I)
7. How many centimeters are in 2.8 meters? (Lesson 12-5)
A. 280 cm B. 28 cm C. 0.028 cm D. 2,800 cm 7. (A) (B) (C) (D)
8. In the figure shown, which side appears to bisect $\angle QVX$? (Lesson 13-3)
F. \overline{AV} G. \overline{VX}
H. \overline{VQ} I. \overline{VR}
- 
8. (F) (G) (H) (I)
9. Which of the following letters of the alphabet has rotational symmetry? (Lesson 13-5)
A. O B. D C. W D. R 9. (A) (B) (C) (D)
10. The area of a parallelogram is 24 square feet. If its base measures 4 feet, what is its height? (Lesson 14-1)
F. 12 feet G. 96 feet H. 3 feet I. 6 feet 10. (F) (G) (H) (I)

Standardized Test Practice *(continued)*

(Chapters 1–14)

Part 2: Short Response/Grid In

Instructions: Enter your grid in answers by writing each digit of the answer in a column box and then shading in the appropriate circle that corresponds to that entry. Write answers to short answer questions in the space provided.

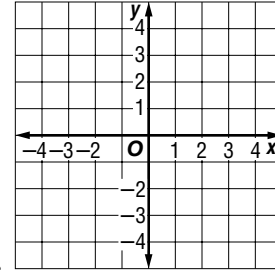

11. Graph and label point D at $(1, -4)$. (Lesson 8-6)

11.

12. The difference between the average July temperature and the average January temperature is 74.2°F . The January temperature is -12.7°F . What is the July temperature? (Lesson 9-3)

12.

•	•	•	•	•
0	0	0	0	0
1	1	1	1	1
2	2	2	2	2
3	3	3	3	3
4	4	4	4	4
5	5	5	5	5
6	6	6	6	6
7	7	7	7	7
8	8	8	8	8
9	9	9	9	9

13.

•	•	•	•	•
0	0	0	0	0
1	1	1	1	1
2	2	2	2	2
3	3	3	3	3
4	4	4	4	4
5	5	5	5	5
6	6	6	6	6
7	7	7	7	7
8	8	8	8	8
9	9	9	9	9

13. How many pounds are in 12 tons? (Lesson 12-2)

14. A circular table has a diameter of 6 feet. Find the area of the tabletop. Use 3.14 for π . (Lesson 14-3)

14. _____

Part 3: Extended Response

Instructions: Write your answers below or to the right of the questions.

15. A company is redesigning their cereal box. In each box is about 202 cubic inches of cereal. The original package was a rectangular prism with a base of 8 inches by 3 inches and a height of 12 inches.

- Draw a picture of the original package. Label its dimensions.
- The box has a disclaimer “Packed by weight, not by volume.” How many cubic inches of the original package is just empty space?
- Could the new package be 4 inches shorter than the original and still hold the cereal? Explain.
- The company chooses a new package that is 2 inches shorter than the original. How much less surface area does it have than the original box?

Unit 6 Test

(Chapters 12–14)

For Questions 1 and 2, find the length of the line segment.

- | | |
|--|-----------------------------------|
| 1. to the nearest half, fourth, or eighth inch | 2. in centimeters and millimeters |
| 3. 80 oz = <u> ?</u> lb | 4. 20 km = <u> ?</u> m |
| 5. 58 mL = <u> ?</u> L | 6. 6 gal = <u> ?</u> qt |

1. _____
 2. _____
 3. _____
 4. _____
 5. _____
 6. _____

Write the metric unit of length that you would use to measure each of the following.

- | | |
|--------------------------|--------------------|
| 7. thickness of a pencil | 8. length of a bed |
|--------------------------|--------------------|

7. _____
 8. _____

Write the metric unit of mass or capacity that you would use to measure each of the following. Then estimate the mass or capacity.

- | | |
|--------|------------------------------|
| 9. dog | 10. bottle of salad dressing |
|--------|------------------------------|

9. _____
 10. _____

Add or subtract.



- | | |
|---|---|
| 11. $\begin{array}{r} 3 \text{ h } 20 \text{ min } 17 \text{ s} \\ + 2 \text{ h } 37 \text{ min } 50 \text{ s} \\ \hline \end{array}$ | 12. $\begin{array}{r} 8 \text{ h } 14 \text{ min} \\ - 2 \text{ h } 18 \text{ min} \\ \hline \end{array}$ |
|---|---|

11. _____
 12. _____

13. If $m\angle Y = 47^\circ$ and $\angle Y$ and $\angle Z$ are supplementary, what is $m\angle Z$?

13. _____

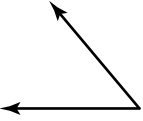
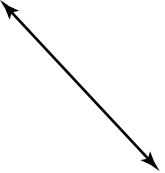
Use a protractor to find the measure of each angle. Then classify each angle as acute, obtuse, right, or straight.

- | | | |
|---|---|--|
| 14.  | 15.  | 16.  |
|---|---|--|

14. _____
 15. _____
 16. _____

17. Estimate the measure of the angle.



17. _____

18. Use a protractor and a straightedge to draw a 135° angle.

18. _____

Identify each polygon. Then tell if it is a regular polygon.

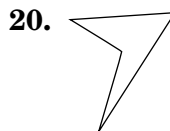
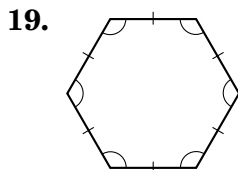

19. _____

20. _____

Unit 6 Test (continued)
(Chapters 12–14)

Draw each line segment or angle having the given measurement. Then use a straightedge and a compass to bisect the line segment or angle.

21. 4 cm

21. _____

22. 66°

22. _____

Tell whether each pair of figures is *congruent*, *similar*, or *neither*.

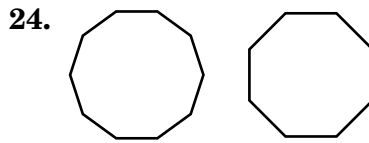
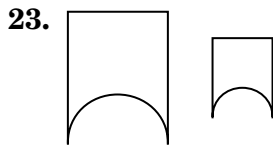

23. _____

24. _____

25. Draw all lines of symmetry in the figure in the answer column.

25.

26. Tell whether the figure at the right has rotational symmetry. Write *yes* or *no*.

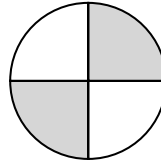

26. _____

Find the area of each figure. Round to the nearest tenth if necessary. Use 3.14 for π .

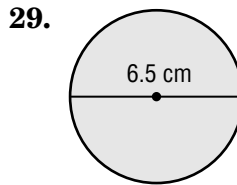
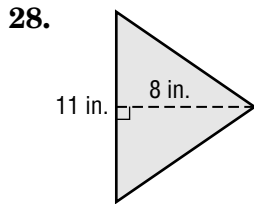
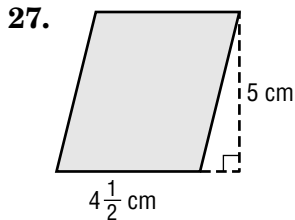

27. _____

28. _____

29. _____

Identify each figure.

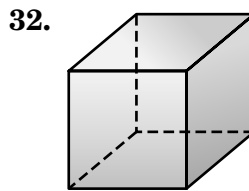
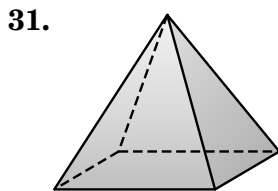
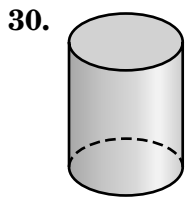

30. _____

31. _____

32. _____

33. **WATER** A large fish tank measures 7 feet by 2 feet by 3 feet. How much water does it take to fill the tank?

33. _____

34. **CRAFTS** Pete is painting a cube whose sides measure 4.5 inches. What is the area he must cover?

34. _____

Second Semester Test

(Chapters 8–14)

1. Which situation is best described by a negative integer?

A. a deposit of \$25

B. a fine of \$12

1. _____

C. a gain of 12 yards

D. a bonus of 10 points

For Questions 2 and 3, use the coordinate plane at the right.

2. Identify the point for the ordered pair $(3, -4)$.

F. Point J

G. Point K

H. Point M

I. Point N

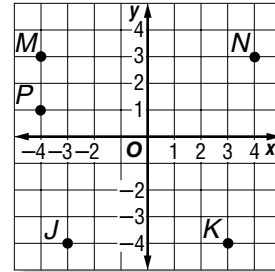

2. _____

3. Which ordered pair names point P ?

A. $(-1, 4)$

B. $(1, -4)$

C. $(-4, 1)$

D. $(4, -1)$

3. _____

For Questions 4 and 5, solve each equation.

4. $3 + m = -4$

F. 7

G. -7

H. 1

I. -1

4. _____

5. $7x + 4 = -10$

A. 14

B. -14

C. 2

D. -2

5. _____

6. **SCHOOL** Janet rides her bike to school 3 times more often than Tomi. If Janet rode her bike to school 12 times last month, how many times did Tomi ride her bike to school last month?

F. 4

G. -4

H. 36

I. -36

6. _____

7. Write the ratio 180 miles on 10 gallons of gasoline as a unit rate.

A. 18 miles

B. $\frac{18 \text{ miles}}{1 \text{ gallon}}$

C. $\frac{1}{18} \text{ miles}$
 $\frac{1}{1 \text{ gallon}}$

D. $\frac{1 \text{ gallon}}{18 \text{ miles}}$

7. _____

8. Write 1.35 as a percent.

F. 0.0135%

G. 13.5%

H. 135%

I. 0.135%

8. _____

9. Find 137% of 600.

A. 822

B. 82.2

C. 8.22

D. 8,220

9. _____

Second Semester Test (continued)

(Chapters 8–14)

10. Which of the following could *not* represent the probability of an event?
 F. 0.672 G. 0 H. 47% I. $\frac{35}{17}$ 10. _____
11. In rolling a number cube, which probability is greatest?
 A. $P(2, 4, 6)$ B. $P(\text{less than } 5)$ C. $P(\text{odd number})$ D. $P(\text{not } 1)$ 11. _____
12. **SHOPPING** A store is having a special on beanbag animals. Customers can choose between cats or dogs available in black, grey, or blue. If Rosalie chooses a style at random, what is the probability she picks a black cat?
 F. 50% G. $\frac{1}{6}$ H. $\frac{2}{5}$ I. $\frac{1}{3}$ 12. _____
13. Complete: 2 yd = ? in.
 A. 24 B. 36 C. 72 D. 12 13. _____
14. Add: $\begin{array}{r} 5 \text{ h } 29 \text{ min} \\ + 2 \text{ h } 50 \text{ min} \\ \hline \end{array}$
 F. 7 h 19 min G. 7 h 79 min H. 6 h 39 min I. 8 h 19 min 14. _____
15. What metric unit of length would you use to measure the length of a pair of scissors?
 A. kilometer B. centimeter C. millimeter D. meter 15. _____
16. If $m\angle A = 57^\circ$ and $\angle A$ and $\angle B$ are supplementary, what is $m\angle B$?
 F. 43° G. 33° H. 303° I. 123° 16. _____
17. **ART** Mandy and Jenny went to the art museum. They were looking at a modern sculpture similar to the figure at the right. How many lines of symmetry does the figure have?
 A. 0 B. 1 C. 2 D. 5 17. _____
18. **ARCHITECTURE** Tyree made a drawing of his dad's office and included a bird's-eye view of two desks as shown. Tell whether the shapes are *congruent*, *similar*, or *neither*.
 F. congruent G. similar H. neither I. both F & G 18. _____

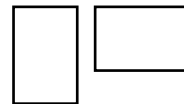
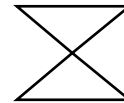

Second Semester Test (continued)

(Chapters 8–14)

For Questions 19 and 20, add or subtract.

19. $-3 + (-6)$

20. $5 - (-2)$

19. _____

20. _____

21. **SPORTS** The Wildcats gained 4 yards on their first play, but then were penalized 10 yards. How many yards did they advance?

21. _____

For Questions 22 and 23, multiply or divide.

22. $(-3)(-6)$

23. $20 \div (-4)$

22. _____

23. _____

24. Rewrite $5 \times (60 + 7)$ using the Distributive Property. Then find the product mentally.

24. _____

For Questions 25–28, solve each equation.

25. $7 + m = 6$

26. $r - 2 = 8$

25. _____

26. _____

27. $-12a = 36$

28. $3n - 7 = 5$

27. _____

28. _____

29. Write the ratio 18 calculators to 22 students as a fraction in simplest form.

29. _____

30. Solve $\frac{z}{7.8} = \frac{1.4}{2.6}$.

30. _____

31. Write 250% as a fraction in simplest form.

31. _____

32. Write 37% as a decimal.

32. _____

33. Find 47% of 237.

33. _____

34. Estimate 76% of 123.

34. _____

For Questions 35–38, use the following information.

A bag of marbles contains 6 green, 8 red, and 10 blue marbles. One marble is chosen without looking and replaced. Find the probability of each event.

35. _____

35. $P(\text{green})$ 36. $P(\text{not blue})$

36. _____

37. The first marble is replaced. If a second marble is picked at random from the bag, what is $P(\text{red and green})$?

37. _____

38. If Bobby repeats the experiment 60 times, about how many times will he pick a blue marble?

38. _____

Second Semester Test *(continued)*

(Chapters 8–14)

For Questions 39 and 40, use the dartboard shown at the right.

39. Find the probability that a randomly thrown dart will land in the shaded region of the dartboard.

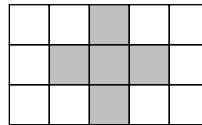

39. _____

40. Suppose Leah throws 45 random darts at the dartboard. About how many will land in a region that is *not* shaded?

40. _____

Write the metric unit of mass or capacity that you would use to measure each of the following. Then estimate the mass or capacity.

41. a boom box

41. _____

42. a bottle of hot sauce

42. _____

Complete.

43. 16 fl oz = ? c

43. _____

44. ? mL = 24 L

44. _____

45. Use a protractor to find the measure of the angle at the right. Then classify the angle as *acute*, *obtuse*, *right*, or *straight*.

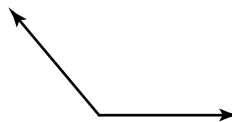

45. _____

46. Use a protractor and a straightedge to draw an angle having a measure of 37° .

46. _____

47. Identify the polygon at the right. Then tell if it is a regular polygon.

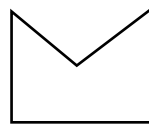

47. _____

For Questions 48 and 49, find the area of the figure to the nearest tenth.

48.

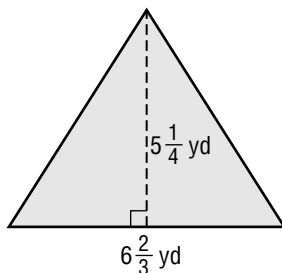

49.

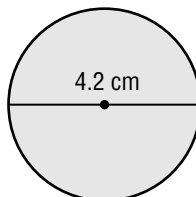

48. _____

49. _____

50. Find the volume of a rectangular prism with length of 3 feet, width of 3.5 feet, and height of 5 feet.

50. _____

Final Test

(Chapters 1–14)

- Write $10 \times 10 \times 10 \times 10$ using an exponent. Then find the value of the power.
 A. 4×10 ; 40 B. 10^4 ; 1,000 C. 10^4 ; 10,000 D. 10×4 ; 10,000 1. _____
- Find the value of $24 \div 4 + 3 \times (2 + 7)$.
 F. 81 G. 33 H. 25 I. 19 2. _____
- Using the line graph, what is the best prediction for the March temperature in Duluth?
 A. 35° B. 30°
 C. 45° D. 20° 3. _____
- Which data set has a mean of 12 and a median of 14?
 F. {13, 12, 11} G. {10, 12, 20}
 H. {3, 14, 20} I. {12, 4, 16, 16} 4. _____
- Which average is most misleading for a data set of 12, 1, 1, 8, 16, and 40?
 A. mean B. median C. mode D. none 5. _____
- What is *ninety-two and thirty-five thousandths* written as a decimal?
 F. 92.3500 G. 92.035 H. 92,035 I. 9.2035 6. _____
- Estimate $4.52 + 3.699 + 4.1754 + 4$ using clustering.
 A. 10 B. 12 C. 16 D. 20 7. _____
- Find: 0.4×6.8 .
 F. 27.2 G. 2.72 H. 272 I. 0.272 8. _____
- SEWING** If a piece of fabric 9.2 yards long needs to be cut into 2.3-yard pieces, how many pieces will you get?
 A. 21.16 B. 0.25 C. 3 D. 4 9. _____
- Which fraction is less than $\frac{4}{9}$?
 F. $\frac{3}{5}$ G. $\frac{1}{2}$ H. $\frac{5}{11}$ I. $\frac{3}{7}$ 10. _____
- Which fraction is *not* in simplest form?
 A. $\frac{7}{11}$ B. $\frac{16}{49}$ C. $\frac{81}{120}$ D. $\frac{12}{125}$ 11. _____
- MONEY** Jenny earned \$18, \$24, and \$27 for babysitting for three days. She only charges for whole hours. What is the minimum she charges per hour?
 F. \$18 G. \$6 H. \$3 I. \$2 12. _____

Average Temperature in Duluth, MN

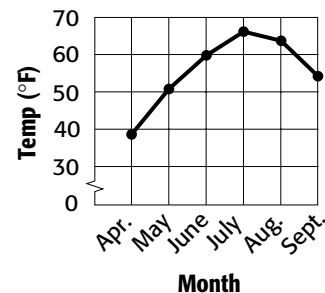

Final Test (continued)

(Chapters 1–14)

13. Estimate $\frac{5}{9} + \frac{5}{12}$.
 A. 1 B. $\frac{5}{6}$ C. 2 D. $\frac{35}{36}$ 13. _____
14. **MUSIC** Amita owns an electric guitar that is $3\frac{1}{12}$ feet long. Rishi owns a Spanish guitar that is $2\frac{1}{4}$ feet long. How much longer is Amita's guitar than Rishi's?
 F. $\frac{1}{6}$ foot G. $\frac{5}{12}$ foot H. $\frac{3}{4}$ foot I. $\frac{5}{6}$ foot 14. _____
15. Find $\frac{5}{7} \times 28$ in simplest form.
 A. 20 B. $\frac{5}{196}$ C. 4 D. $\frac{140}{7}$ 15. _____
16. Divide $1\frac{2}{5}$ by $1\frac{1}{5}$. Write in simplest form.
 F. $\frac{6}{7}$ G. $\frac{42}{25}$ H. $\frac{7}{6}$ I. $1\frac{1}{6}$ 16. _____
17. **CANDY** Awinita wants to divide $3\frac{5}{7}$ pounds of candy evenly among 4 of her friends. How many pounds of candy will each friend get?
 A. $\frac{13}{14}$ lb B. $14\frac{6}{7}$ lb C. $\frac{26}{28}$ lb D. $1\frac{1}{13}$ lb 17. _____
18. Find the next term in the sequence $4, 6\frac{1}{3}, 8\frac{2}{3}, 11, \dots$.
 F. $12\frac{1}{3}$ G. $8\frac{2}{3}$ H. $13\frac{1}{3}$ I. 13 18. _____
19. Which situation is *not* best described by a negative integer?
 A. a withdrawal of \$35 B. a fine of \$20
 C. a drop of 5° D. a growth of 4 inches 19. _____
20. Use the coordinate plane at the right. Identify the point for the ordered pair $(-2, 3)$.
 F. Point A G. Point B
 H. Point C I. Point D 20. _____
21. Solve $z - 4 = -1$.
 A. 3 B. -3
 C. 5 D. -5 21. _____
22. Solve $2m + 4 = -2$.
 F. 0 G. -6 H. 3 I. -3 22. _____

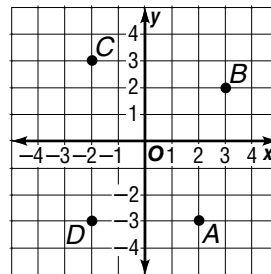

Final Test (continued)

(Chapters 1–14)

23. Solve $\frac{18}{x} = \frac{20}{50}$.
 A. 900 B. 7.2 C. 0.2 D. 45 23. _____
24. **BIRDS** A scale model of a bee hummingbird has a scale of 1 inch = 0.25 inch. If the length of the bird on the model is 8 inches, what is the actual length of the bird?
 F. 32 in. G. 2 in. H. 0.03 in. I. 4 in. 24. _____
25. What percent of the figure is shaded?
 A. 80% B. 60%
 C. 64% D. 36% 25. _____
26. **SHOPPING** A store has plain or striped ties available in shades of black, grey, red, or tan. If Alex chooses a style at random, what is the probability he picks a red striped tie?
 F. $\frac{1}{6}$ G. $\frac{1}{4}$ H. $\frac{1}{3}$ I. $\frac{1}{8}$ 26. _____
27. **HEALTH** Which location is the best place to find a sample to survey how often people take vitamin supplements for their health?
 A. a grocery store B. a health club
 C. a fast-food restaurant D. a hospital 27. _____
28. Complete: 24 ft = ? yd.
 F. 12 G. 8 H. 72 I. 2 28. _____
29. Complete: 20 c = ? gal.
 A. $1\frac{1}{4}$ B. $2\frac{1}{2}$ C. 5 D. 10 29. _____
30. Complete: 20 cm = ? mm.
 F. 0.2 G. 200 H. 2 I. 2,000 30. _____
31. Estimate the measure of the angle shown at the right.
 A. 45° B. 90° C. 30° D. 160° 31. _____
32. Identify the point that bisects the line segment \overline{AC} .
 F. B G. C H. D I. E 32. _____
33. Classify a 120° angle.
 A. acute B. right C. obtuse D. straight 33. _____

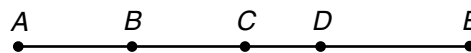
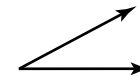
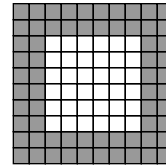

Final Test (continued)
(Chapters 1–14)

34. Find the prime factorization of 66.

BOOKS For Questions 35 and 36, refer to the table that shows Tanya's books.

Book	Frequency
Poetry	2
Fantasy	6
Mystery	10

35. Make a bar graph of the data.

Tanya's Books

36. A book is selected at random. Write the probability $P(\text{fantasy or poetry})$ as a percent, a fraction, and a decimal.

37. **TELEVISION** According to the circle graph at the right, what percent of households has more than one TV?

Number of TVs in U.S. Households

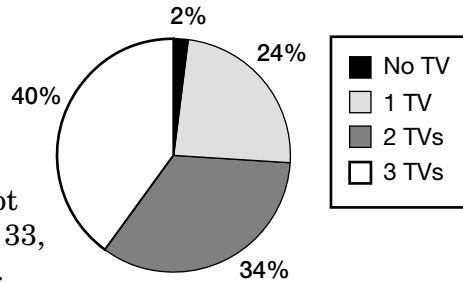

38. Make a stem-and-leaf plot of the following data: 32, 33, 45, 40, 33, 12, 19, and 28.

39. Order 8.4, 2.5, 1.375, 1.5, and 1.44 from least to greatest.

40. How much greater is 2.5 than 1.44?

41. Find the perimeter of a square with sides of 12.32 meters.

42. Find the circumference of a circle whose diameter is 11.6 feet. Round to the nearest tenth.

For Questions 43–46, multiply or divide.

43. 24.6×0.08

44. $24.8 \div 3.2$

45. $4(-6)$

46. $(-14) \div (-2)$

47. Find the GCF of 32 and 48.

Write each fraction as a decimal.

48. $\frac{3}{16}$

49. $\frac{2}{15}$

Final Test (continued)

(Chapters 1–14)

Add or subtract. Write in simplest form.

50. $6\frac{3}{4} + 2\frac{2}{3}$

50. _____

51. $10 - 4\frac{7}{12}$

51. _____

52. $\frac{1}{2} + \frac{3}{8} + \frac{1}{4}$

52. _____

For Questions 53 and 54, multiply or divide. Write in simplest form.

53. $3\frac{3}{8} \times 1\frac{1}{3}$

53. _____

54. $2\frac{4}{7} \div 4\frac{1}{2}$

54. _____

55. Estimate $\frac{3}{8} \times 73$ using compatible numbers.

55. _____

56. Order 5, -6, 0, 3, -2 from least to greatest.

56. _____

For Questions 57 and 58, add or subtract.

57. $-5 + (-2)$

58. $1 - (-8)$

57. _____

58. _____

59. Complete the function table. Then graph the function.

input (x)	output ($3x$)
-2	■
-1	■
1	■

59. _____

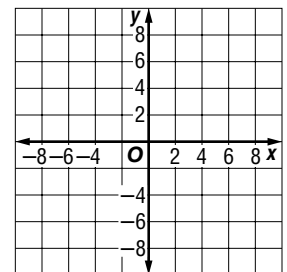

60. Write the ratio 24 bottles of water for \$6.00 as a unit rate.

60. _____

61. Write $\frac{42}{80}$ as a percent.

61. _____

62. Write 0.205 as a percent.

62. _____

63. Find 60% of 240.

63. _____

For Questions 64–66, solve each equation.

64. $k + 7 = 4$

65. $4n = 28$

64. _____

65. _____

66. $\frac{x}{24} = \frac{15}{36}$

66. _____

For Questions 67 and 68, a number card from 1 to 8 is chosen without looking and is replaced. Find the probability of each event.67. $P(4 \text{ or } 8)$ 68. $P(\text{less than } 4)$

67. _____

68. _____

Final Test (continued)

(Chapters 1–14)

69. **SCHOOL** Amy surveys 24 sixth graders and finds that 18 prefer English to math. If there are 120 sixth graders at Amy's school, predict how many prefer English.

69. _____

70. Find the probability that a randomly thrown dart will land in a shaded region of the dartboard at the right.

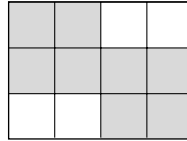

70. _____

For Questions 71 and 72, find the length of the line segment.

71. to the nearest half, fourth, or eighth inch

71. _____

72. in centimeters and millimeters

72. _____

73. Write the metric unit you would use to measure the capacity of a soup bowl. Then estimate the capacity.

73. _____

74. Add: $3 \text{ h } 45 \text{ min } 28 \text{ s}$
 $+ 1 \text{ h } 20 \text{ min } 50 \text{ s}$

74. _____

75. Tell whether the pair of figures is *congruent*, *similar*, or *neither*.

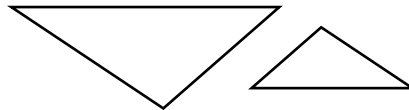

75. _____

76. Identify the polygon at the right. Tell if it is a regular polygon. Write *yes* or *no*.

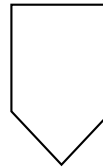

76. _____

For Questions 77 and 78, use the figure at the right.

77. Tell whether the figure has rotational symmetry. Write *yes* or *no*.

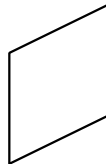

77. _____

78. Tell how many lines of symmetry the figure has.

78. _____

79. Find the surface area of the rectangular prism shown at the right.

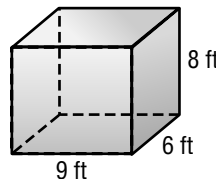

79. _____

80. Find the area of a triangle that has a base of $6\frac{2}{3}$ centimeters and a height of $2\frac{1}{2}$ centimeters.

80. _____

Standardized Test Practice

Student Recording Sheet (Use with pages 582–583 of the Student Edition.)

Part 1: Multiple Choice

Select the best answer from the choices given and fill in the corresponding oval.

1. (A) (B) (C) (D)

4. (F) (G) (H) (I)

7. (A) (B) (C) (D)

2. (F) (G) (H) (I)

5. (A) (B) (C) (D)

8. (F) (G) (H) (I)

3. (A) (B) (C) (D)

6. (F) (G) (H) (I)

Part 2: Short Response/Grid in

Solve the problem and write your answer in the blank.

For grid in questions, also enter your answer by writing each number or symbol in a box. Then fill in the corresponding circle for that number or symbol.

- 9. _____
- 10. _____ (grid in)
- 11. _____ (grid in)
- 12. _____
- 13. _____ (grid in)
- 14. _____ (grid in)
- 15. _____ (grid in)
- 16. _____
- 17. _____
- 18. _____ (grid in)
- 19. _____
- 20. _____

10.		11.		13.	
14.		15.		18.	

Answers

Part 3: Extended Response

Record your answer for Question 21 on the back of this paper.

Standardized Test Practice

Rubric (Use to score the Extended Response question on page 583 of the Student Edition.)

General Scoring Guidelines

- If a student gives only a correct numerical answer to a problem but does not show how he or she arrived at the answer, the student will be awarded only 1 credit. All extended response questions require the student to show work.
- A fully correct answer for a multiple-part question requires correct responses for all parts of the question. For example, if a question has three parts, the correct response to one or two parts of the question that required work to be shown is *not* considered a fully correct response.
- Students who use trial and error to solve a problem must show their method. Merely showing that the answer checks or is correct is not considered a complete response for full credit.

Exercise 21 Rubric

Score	Specific Criteria
4	The product of 12 and 8 is correctly computed to determine the area of the floor covered by the figure to be 96 cm^2 . The volume is correctly computed to be $4 \times 12 \times 8$ or 384 cm^3 . An accurate drawing of the figure is given.
3	The area and volume are computed correctly, but the figure is carelessly drawn. OR The drawing is correct. The method of finding the area and volume are correct, but a computational error is made.
2	The area and volume are found correctly, but the drawing is incorrect. OR The area is found correctly and the drawing is correct, but the volume is incorrect. OR The volume is found correctly and the drawing is correct, but the area is incorrect.
1	The area is found correctly, but the volume and drawing are incorrect. OR The volume is found correctly, but the area and drawing are incorrect. OR The drawing is correct, but the area and volume are incorrect.
0	Response is completely incorrect.

NAME _____ DATE _____ PERIOD _____

14-1 Study Guide and Intervention

Area of Parallelograms

The area A of a parallelogram is the product of any base b and its height h .

Symbols $A = bh$

Model

EXAMPLES Find the area of each parallelogram.

1

The base is 4 units,
and the height is 7 units.

$A = bh$
 $A = 4 \times 7$
 $A = 28$
The area is 28 square units
or 28 units².

2

$A = bh$
 $A = 4.5 \times 2.2$
 $A = 9.9$
The area is 9.9 square inches
or 9.9 in².

NAME _____ DATE _____ PERIOD _____

14-1 Practice: Skills

Area of Parallelograms

Find the area of each parallelogram. Round to the nearest tenth if necessary.

1. **8 units²**
2. **28 units²**
3. **88.7 m²**
4. **6.3 cm²**
5. **22.7 yd²**
6. **88.7 m²**

NAME _____ DATE _____ PERIOD _____

14-1 Practice: Skills

Area of Parallelograms

Find the area of each parallelogram. Round to the nearest tenth if necessary.

1. **12 units²**
2. **18 units²**
3. **21 ft²**
4. **63 yd²**
5. **12.5 cm²**
6. **90 yd²**
7. **84 m²**
8. **155 in²**
9. **144 in²**
10. **61.5 cm²**
11. **100.1 km²**
12. **38.0 m²**
13. **305 ft²**
14. **63 7/8 yd²**
15. **51.7 cm²**

NAME _____ DATE _____ PERIOD _____

14-1 Practice: Skills

Area of Parallelograms

Find the area of each parallelogram. Round to the nearest tenth if necessary.

16. What is the measure of the area of a parallelogram with a base of $6\frac{2}{3}$ inches and a height of $1\frac{1}{2}$ inches? **10 in²**
17. Find the area of a parallelogram with base $7\frac{1}{5}$ yards and height $1\frac{1}{9}$ yards. **8 yd²**

14-1 Reading to Learn Mathematics
Area of Parallelograms

Pre-Activity Complete the Mini Lab at the top of page 546 in your textbook. Write your answers below.

- How does a parallelogram relate to a rectangle? **Sample answer: A parallelogram is related to a rectangle in that a parallelogram can be formed using a rectangle.**
- What part of the parallelogram corresponds to the length of the rectangle? **the base**
- What part corresponds to the rectangle's width? **height**
- Write a formula for the area of a parallelogram. **area = base \times height**

Reading the Lesson

- Look back at Lesson 1-8, Geometry: Area of Rectangles. Write the definition for the area of a figure. **the number of square units needed to cover a surface**
- Look at the models in the Mini Lab at the top of page 546 in your textbook. How can you tell from the models that the areas of the rectangle and the parallelogram are the same? **Sample answer: Both are formed from the same number of square units as indicated by the grid paper.**
- Look at Examples 2 and 3 on page 547. Explain what the dotted lines in the figures represent. **Sample answer: The dotted lines show the height of the parallelogram. It can be measured outside of the figure.**

Helping You Remember

- Work with a partner. Using models, demonstrate that the area of a parallelogram equals the product of any base of the parallelogram and its height. **See students' work.**

14-1 Practice: Word Problems
Area of Parallelograms

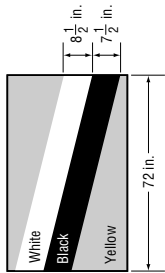
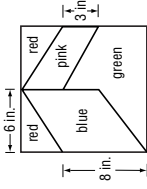
<p>1. SUNFLOWERS Norman is a sunflower farmer. His farm is in the shape of a parallelogram with a base measuring 3 kilometers and a height measuring 4.2 kilometers. To the nearest tenth of an acre, what is the total land area Norman uses? 12.6 km²</p>	<p>2. VOLLEYBALL Ella and Veronica are in charge of making a banner for the volleyball game this Saturday. How much poster paper will they need for a parallelogram-shaped banner with height $3\frac{1}{2}$ feet and base 6 feet? Explain how you found your answer. 21 ft²; Multiply the base, 6, and the height, $3\frac{1}{2}$, to find the area.</p>
<p>3. FLAGS Joseph is painting the flag of Brunei (a country in Southeast Asia) for a geography project at school. How many square inches will he cover with white paint?</p>  <p>612 in²</p>	<p>4. FLAGS Use the flag from Exercise 3. How many square inches will Joseph cover with black paint? 540 in²</p>
<p>5. QUILTING The pattern shows the dimensions of a quilting square that Sydney will use to make a quilt. How much blue fabric will she need? Explain how you found your answer.</p>  <p>48 in²; The blue part is a parallelogram with an 8-in. base and a height of 6 in. Multiply 8 and 6 to find the area.</p>	<p>6. QUILTING Use the quilting pattern from Exercise 5. How much pink fabric will Sydney need? 18 in²</p>

Lesson 14-1

NAME _____ DATE _____ PERIOD _____

14-1 Enrichment

You Can Count On It!
How many triangles are there in the figure at the right?
How many parallelograms?
When counting shapes in a figure like this, you usually have to think of different sizes.

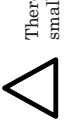

There are four small triangles.

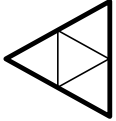

There is one large triangle.

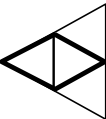

There are five triangles in all.

You also have to think of different positions.

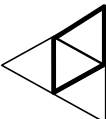

There are three parallelograms in all.

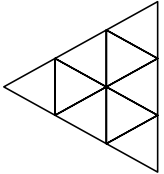

There are three parallelograms in all.

1. Now it's your turn. How many triangles are in the figure below?
How many parallelograms? Use the space at the right to organize your counting.

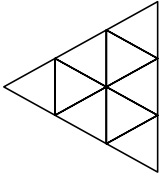

$$\begin{array}{r} \triangle \quad 9 \\ \triangle \quad 3 \\ \triangle \quad 1 \\ \hline 13 \text{ triangles} \end{array}$$

$$\begin{array}{r} \triangle \quad 9 \\ \triangle \quad 6 \\ \triangle \quad 1 \\ \hline 15 \text{ parallelograms} \end{array}$$

2. A trapezoid is a quadrilateral with only one pair of sides parallel, as shown at the right. How many trapezoids are in the figure in Exercise 1?



$$\begin{array}{r} \triangle \quad 12 \\ \triangle \quad 3 \\ \hline 15 \text{ trapezoids} \end{array}$$

3. **CHALLENGE** How many triangles, parallelograms, and trapezoids are in the figure at the right?

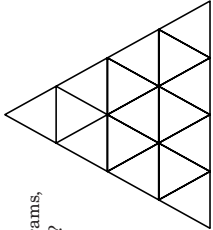

$$\begin{array}{r} \triangle \quad 27 \\ \triangle \quad 45 \\ \triangle \quad 57 \\ \hline \end{array}$$

NAME _____ DATE _____ PERIOD _____

14-2 Study Guide and Intervention

Area of Triangles

The area A of a triangle is one half the product of any base b and its height h .

Symbols $A = \frac{1}{2}bh$

Model

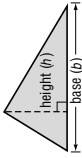

Lesson 14-1

NAME _____ DATE _____ PERIOD _____

14-2 Study Guide and Intervention

Area of Triangles

The area A of a triangle is one half the product of any base b and its height h .

Symbols $A = \frac{1}{2}bh$

Model

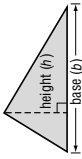

EXAMPLES Find the area of each triangle.

1

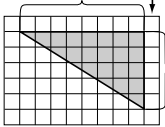

The measure of the base is 5 units, and the height is 8 units.

Area of a triangle

$$A = \frac{1}{2}bh$$

$$A = \frac{1}{2}(5)(8)$$

$$A = \frac{1}{2}(40)$$

$$A = 20$$

The area of the triangle is 20 square units.

2

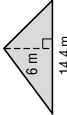

14.4 m

$$A = \frac{1}{2}bh$$

$$A = \frac{1}{2}(14.4)(6)$$

$$0.5 \times 14.4 \times 6 = 43.2$$

Replace b with 5 and h with 8.

Multiply. $5 \times 8 = 40$

Replace b with 14.4 and h with 6.

The area of the triangle is 43.2 square meters.

EXERCISES Find the area of each triangle. Round to the nearest tenth if necessary.

1.

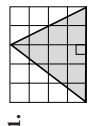

10 units²

2.

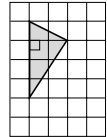

4 units²

3.

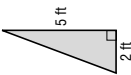

5 ft²

4.

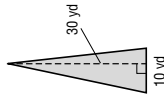

150 yd²

5.

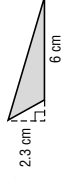

6.9 cm²

6.

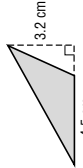

7.2 cm²

© Glencoe/McGraw-Hill

703

Mathematics: Applications and Concepts, Course 1

704

Mathematics: Applications and Concepts, Course 1

Answers

NAME _____ DATE _____ PERIOD _____

14-2 Practice: Word Problems

Area of Triangles

For Exercises 1-6, round to the nearest tenth if necessary.

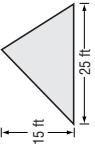
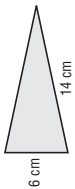
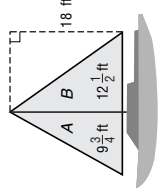
<p>1. CARPETING Courtney wants to carpet part of her bedroom that is shaped like a right triangle with base 4 meters and height 5.2 meters. How much carpet will she need? 10.4 m²</p>	<p>2. LAWN Mrs. Giuntini's lawn is triangle-shaped with a base of 25 feet and a height of 10 feet. What is the area of Mrs. Giuntini's lawn? Explain how you found your answer. 125 ft²; The area of a triangle is $\frac{1}{2}bh$. So, $\frac{1}{2} \times 25 \times 10 = 125$.</p>
<p>3. BUILDING Norma has an A-frame cabin. The back is shown below. How many square feet of paint will she need to cover the back of the cabin?</p>  <p style="text-align: center;">187$\frac{1}{2}$ ft²</p>	<p>4. SNACKS The dough that will be used to make a pig in a blanket is shown below. Before it is rolled around a sausage, it is brushed with vegetable oil. What is the area that needs to be covered with oil? Explain how you found your answer.</p>  <p style="text-align: center;">42 cm²; Sample answer: The shape of the dough is a triangle. It has a base of 6 cm and a height of 14 cm. The area is $\frac{1}{2} \times 6 \times 14$ or 42.</p>
<p>5. SAILING Daniel just bought a used sailboat with two sails that need replacing. How much sail fabric will Daniel need if he replaces sail A?</p>  <p style="text-align: center;">87$\frac{3}{4}$ ft²</p>	<p>6. SAILING Use the picture from Exercise 5. How much sail fabric will Daniel need if he replaces sail B? 112$\frac{1}{2}$ ft²</p>

NAME _____ DATE _____ PERIOD _____

14-2 Practice: Skills

Area of Triangles

Find the area of each triangle. Round to the nearest tenth if necessary.

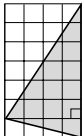
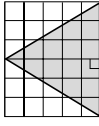
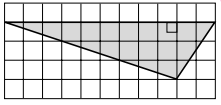
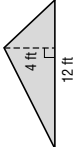
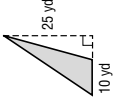
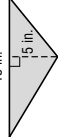
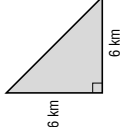
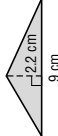
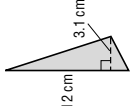
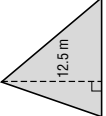
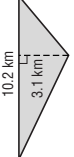
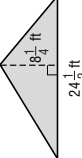
1.  **14 units²**
2.  **15 units²**
3.  **16.5 units²**
4.  **24 ft²**
5.  **125 yd²**
6.  **37.5 in²**
7.  **18 km²**
8.  **9.9 cm²**
9.  **18.6 cm²**
10.  **93.8 m²**
11.  **15.8 km²**
12.  **101 $\frac{1}{16}$ ft²**
13. base: 4 in. height: 11 in. **22 in²**
14. base: 4 $\frac{3}{4}$ yd height: 1 $\frac{1}{3}$ yd **3 $\frac{1}{6}$ yd²**
15. base: 5 $\frac{1}{4}$ ft height: 2 $\frac{2}{3}$ ft **7 ft²**

NAME _____ DATE _____ PERIOD _____

14-2 Reading to Learn Mathematics

Area of Triangles

Pre-Activity Read the introduction at the top of page 551 in your textbook. Write your answers below.

- Compare the two triangles.
They have the same size and shape.
- What figure is formed by the two triangles?
a parallelogram
- Make a conjecture about the relationship that exists between the area of one triangle and the area of the entire figure. **The area of the triangle is half the area of the parallelogram.**

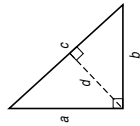

Reading the Lesson

- Look at the figure at the right. Explain how the height can be a , b , or d . **Sample answer: The height is the shortest distance from the base to the opposite vertex, and the base can be any side of the triangle. If a is the base, b is the height. If b is the base, a is the height. If c is the base, d is the height.**
- Using models, demonstrate that congruent triangles have the same area.
See students' work.
- Look at the illustrations of h on page 551. What is the symbol found where h and b meet? How does that affect the length of h ? **Sample answer: The symbol indicates that the angle formed by h and b is a right angle. When the angle is a right angle, h is shorter than if the angle were any other measure.**

Helping You Remember

- Work with a partner. Using models, demonstrate that the area of a triangle is one-half the product of the base b and the height h of the triangle. **See students' work.**

NAME _____ DATE _____ PERIOD _____

14-2 Enrichment

Area of Composite Figures

A composite figure is made up, or composed, of other figures. For example, the L-shaped figure at the right is composed of two rectangles. To find the area of the L-shape, find the area of each rectangle, then add.

Area of A	Area of B
$A = \ell \times w$	$A = \ell \times w$
$A = 10 \times 6$	$A = 20 \times 8$
$A = 60$	$A = 160$

So the area of the L-shaped figure is $60 \text{ ft}^2 + 160 \text{ ft}^2$, or 220 ft^2 .

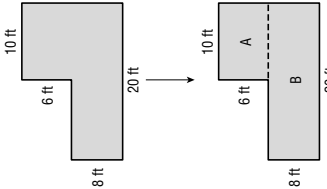

Find the area of each composite figure.

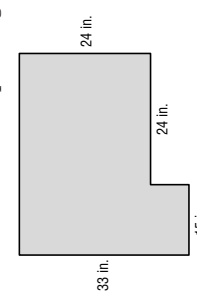
- 

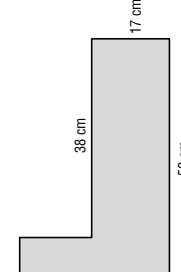
1,071 in²
- 

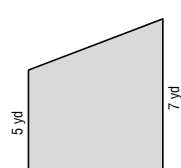
1,030 cm²
- 

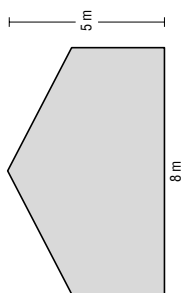
36 yd²
- 

32 m²

5. CHALLENGE Find the area of the shaded region in the figure at the right.

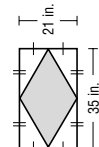

367 1/2 in²

NAME _____ DATE _____ PERIOD _____

14-3

Practice: Skills
Area of Circles

Find the area of each circle to the nearest tenth. Use 3.14 for π .

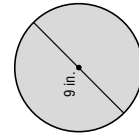
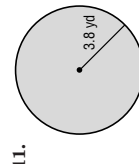
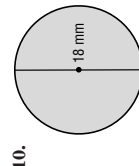
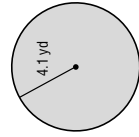
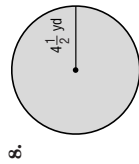
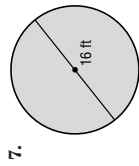
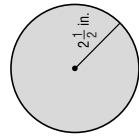
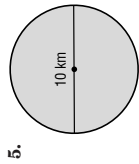
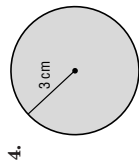
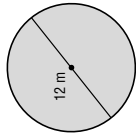
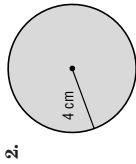
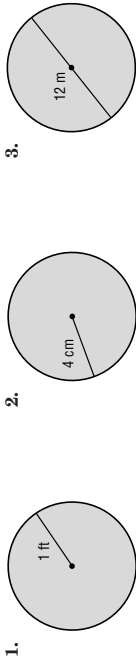

13. What is the area of a circle whose radius is 4.2 yards?
55.4 yd²

14. Find the area of a circle with a diameter of 13 meters.
132.7 m²

15. What is the area of a circle whose radius is 6.6 inches?
136.8 in²

© Glencoe/McGraw-Hill

710

Mathematics: Applications and Concepts, Course 1

NAME _____ DATE _____ PERIOD _____

14-3

Study Guide and Intervention
Area of Circles

The area A of a circle is the product of π and the square of the radius r .

Symbols $A = \pi r^2$

Model

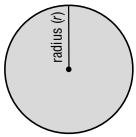

EXAMPLE 1 Find the area of the circle to the nearest tenth.

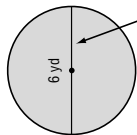

The diameter is 6 yards. So, the radius is $6 \div 2$ or 3 yards.

Area of a circle
 $A = \pi r^2$
 $A \approx 3.14 \times 3^2$
Replace π with 3.14 and r with 3.
 $A \approx 3.14 \times 9$
Evaluate 3^2 .
 $A \approx 28.26$
Use a calculator.
The area of the circle is about 28.3 square yards.

EXERCISES

Find the area of each circle to the nearest tenth. Use 3.14 for π .

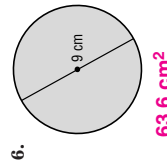
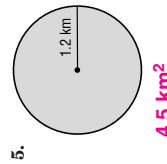
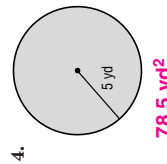
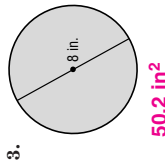
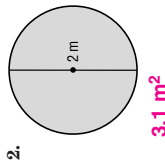
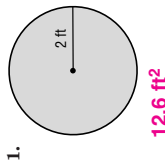

Lesson 14-3

© Glencoe/McGraw-Hill

709

Mathematics: Applications and Concepts, Course 1

NAME _____ DATE _____ PERIOD _____

14-3 Practice: Word Problems Area of Circles

For Exercises 1-4, find each area to the nearest tenth. Use 3.14 for π .

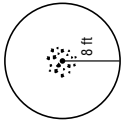
<p>1. SWIMMING POOLS Jensen's parents put him in charge of ordering a cover for their new swimming pool. The pool is in the shape of a circle and has a radius of 14 feet. What will the area of the cover need to be? 615.4 ft²</p>	<p>2. BASKETBALL Thompson School will paint the center circle of the basketball court with yellow paint, one of the school colors. The circle has a radius of 2 feet. What is the area that will be painted yellow? 12.6 ft²</p>
<p>3. BASEBALL The pitcher's mound on a regulation baseball field has a diameter of 18 feet. What is the area of a pitcher's mound? 254.3 ft²</p>	<p>4. CAMPING A group of campers needs to clear away twigs and bark on the ground to make a fire circle for people to safely sit around the campfire. What is the area that they need to clear?</p> <div style="text-align: center;">  <p>201.0 ft²</p> </div>

For Exercises 5 and 6, find each area to the nearest tenth. Use 3.14 for π . Use the following information.

SCIENCE Hal and Frank are conducting a science experiment. They drop a pebble into a pond and measure the radius of the circles of waves.

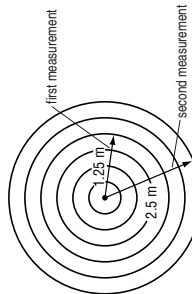

<p>5. What was the area covered by waves the first time it was measured? 4.9 m²</p>	<p>6. What was the area covered by waves the second time it was measured? Explain how you found your answer. 19.6 m²; Sample answer: After a longer time, the radius would be greater. The area is 3.14×2.5^2.</p>
---	--

NAME _____ DATE _____ PERIOD _____

14-3 Reading to Learn Mathematics Area of Circles

Pre-Activity Complete the Mini Lab at the top of page 556 in your textbook. Write your answers below.

- What shape does the figure look like?
a parallelogram
- What part of the circle represents the figure's height?
the radius
- Relate the circle's circumference to the base of the figure.
The base is half the circumference.
- How would you find the area of the figure?
Multiply the base and the height.

Reading the Lesson

- The second sentence below the Mini Lab says, "The parts can then be arranged to form a figure that resembles a parallelogram." How is the parallelogram-like figure in the Mini Lab different from a parallelogram?
Sample answer: In a parallelogram, all sides are straight lines. But in the figure in the Mini Lab, the base is made up of sections that are curved.
- Draw a circle. Label the circumference, radius, and diameter.
See students' work.

Helping You Remember

- To help yourself practice computing the area of a circle, find a few circular objects such as plates, cups, and tops of cans. Measure each radius or diameter with a ruler and then find the area of the circle.
See students' work.

Lesson 14-3

NAME _____ DATE _____ PERIOD _____

14-3 Practice: Word Problems Area of Circles

For Exercises 1-4, find each area to the nearest tenth. Use 3.14 for π .

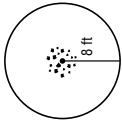
<p>1. SWIMMING POOLS Jensen's parents put him in charge of ordering a cover for their new swimming pool. The pool is in the shape of a circle and has a radius of 14 feet. What will the area of the cover need to be? 615.4 ft²</p>	<p>2. BASKETBALL Thompson School will paint the center circle of the basketball court with yellow paint, one of the school colors. The circle has a radius of 2 feet. What is the area that will be painted yellow? 12.6 ft²</p>
<p>3. BASEBALL The pitcher's mound on a regulation baseball field has a diameter of 18 feet. What is the area of a pitcher's mound? 254.3 ft²</p>	<p>4. CAMPING A group of campers needs to clear away twigs and bark on the ground to make a fire circle for people to safely sit around the campfire. What is the area that they need to clear?</p> <div style="text-align: center;">  <p>201.0 ft²</p> </div>

For Exercises 5 and 6, find each area to the nearest tenth. Use 3.14 for π . Use the following information.

SCIENCE Hal and Frank are conducting a science experiment. They drop a pebble into a pond and measure the radius of the circles of waves.

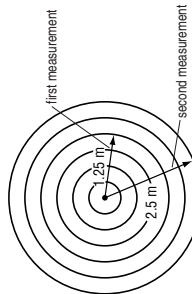

<p>5. What was the area covered by waves the first time it was measured? 4.9 m²</p>	<p>6. What was the area covered by waves the second time it was measured? Explain how you found your answer. 19.6 m²; Sample answer: After a longer time, the radius would be greater. The area is 3.14×2.5^2.</p>
---	--

NAME _____ DATE _____ PERIOD _____

14-4 Study Guide and Intervention Three-Dimensional Figures

Three-dimensional figures are shapes with length, width, and depth (or height). Some terms associated with three-dimensional figures are face, edge, vertex, and lateral face.

The polygons that form three-dimensional figures are called **faces**.

The faces intersect to form **edges**.

The edges intersect to form **vertices**.

The sides are called **lateral faces**.

Prisms have two parallel **bases** and at least three lateral faces that are rectangles.

Some three-dimensional figures have curved surfaces and no edges.

EXERCISES

Identify each figure.

- square prism or cube**
- triangular pyramid**
- square pyramid**
- sphere**
- triangular pyramid**
- rectangular prism**

© Glencoe/McGraw-Hill

714

Mathematics: Applications and Concepts, Course 1

NAME _____ DATE _____ PERIOD _____

14-3 Enrichment

Area of Sectors

In the circle at the right, the vertex of $\angle AOB$ is the center of the circle. So, $\angle AOB$ is called a **central angle** of the circle, and the shaded region is a **sector** of the circle. When you know the radius of the circle and the measure of the central angle, it's easy to find the area of the sector.

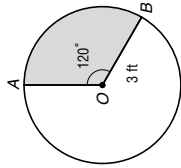

First find the area of the circle. Then find what fractional part of the circle is in the sector.

$$A = \pi r^2$$

$$A \approx 3.14 \cdot (3)^2$$

$$A \approx 3.14 \cdot 9$$

$$A \approx 28.26$$

$$\text{degree measure of central angle} \rightarrow \frac{120}{360} = \frac{1}{3}$$

$$\text{degree measure of circle} \rightarrow$$

So, the area of the sector is about $\frac{1}{3}$ of 28.26 ft^2 , or about 9.42 ft^2 .

Find the area of each shaded sector. Use 3.14 for π .

- 75.36 cm²**
- 169.56 cm²**
- 339.12 cm²**
- 15.7 ft²**
- 47.1 in²**
- 1,099 cm²**
- CHALLENGE** In the circle at the right, the shaded region is called a **segment** of the circle. Find the area of the segment. **18.24 in²**

© Glencoe/McGraw-Hill

713



Mathematics: Applications and Concepts, Course 1

NAME _____ DATE _____ PERIOD _____

14-4 Practice: Skills

Three-Dimensional Figures

Identify each figure.

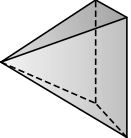
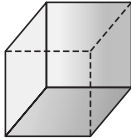
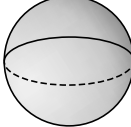
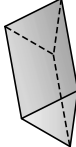
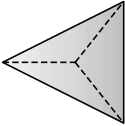
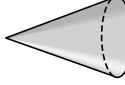
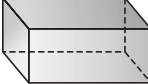
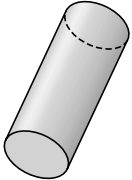
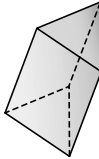
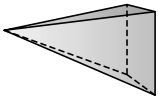
1. 	2. 	3. 
rectangular prism	cylinder	square pyramid
4. 	5. 	6. 
cube or square prism	sphere	triangular prism
7. 	8. 	9. 
triangular pyramid	cone	rectangular prism
10. 	11. 	12. 
cylinder	triangular prism	square pyramid



LESSON 14-4

© Glencoe/McGraw-Hill 715 Mathematics: Applications and Concepts, Course 1

NAME _____ DATE _____ PERIOD _____

14-4 Practice: Word Problems

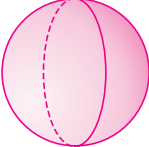
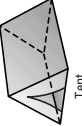
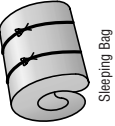
Three-Dimensional Figures

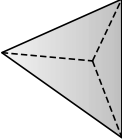
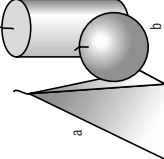
<p>1. TENNIS As professional tennis players, Venus and Serena Williams strike tennis balls with rackets. Draw the figure that represents a tennis ball. What type of figure is this? sphere</p> 	<p>2. BACKPACKING Below are pictures of some of the objects Kelly takes with her for backpacking trips. Identify the figure each picture represents.</p>  triangular prism  cylinder
<p>3. MECHANICS A mechanic uses a funnel when he or she puts fluids into cars. What type of figure does a funnel represent? Draw the figure. cone</p> 	<p>4. DESIGN Rachael Johnson is a toy designer. She uses square blocks of wood to make alphabet blocks. Draw and name the figure that an alphabet block represents. cube</p> 
<p>5. FIGURES Alice and Julie were arguing over the name of this figure. What is the name of the figure? How do you know?  Triangular pyramid; it has a triangular base and three lateral faces. </p>	<p>6. CANDLES Kevin arranged several scented candles on his kitchen table before his birthday party started. Use the picture of Kevin's arrangement to name the type of figure each candle represents.</p>  <p>a. square pyramid b. sphere c. cylinder</p>

© Glencoe/McGraw-Hill 716 Mathematics: Applications and Concepts, Course 1

14-4 Enrichment

Point of View

At the right is a square pyramid as seen from a point of view that is slightly above and to the right. Here is the same pyramid when you look at it from three different points of view.



Notice that these views appear two-dimensional. Architects, engineers, and designers often use views like these to provide a detailed description of a three-dimensional object.

Identify the figure that each set of views represents.

- cone**
- rectangular prism**
- cylinder**
- sphere**

5. This figure is called a *truncated cone*. In the space at the right, sketch front, side, and top views of the figure.

6. **CHALLENGE** At the right, you see three different views of the same cube. What symbol is on the face opposite the plus sign? **\$**

14-4 Reading to Learn Mathematics

Three-Dimensional Figures

Pre-Activity Read the introduction at the top of page 564 in your textbook. Write your answers below.

1. What shape does the delta kite resemble? **a quadrilateral**
2. Name the shape that each side of the box kite resembles. **rectangle or triangle**
3. Describe how the shape of the box kite differs from the shape of the delta kite. **Sample answer: The delta kite appears flat and the box kite appears to have depth.**

Reading the Lesson

For Exercises 4-11, tell whether each phrase describes a *prism*, *pyramid*, *cone*, *cylinder*, or *sphere*.

4. no faces **sphere**
5. curved surface **cone, cylinder, sphere**
6. no bases **sphere**
7. lateral faces that are rectangles **prism**
8. one base **pyramid, cone**
9. lateral faces that are triangles **pyramid**
10. two bases **prism, cylinder**
11. one vertex **cone**
12. What determines the name of a prism or pyramid? **the shape of the base**
13. Compare a triangular pyramid and a square pyramid. How are they similar? How are they different? **similar—one base, at least three lateral faces that are triangles; different—shape of base (triangle vs. square) and number of lateral faces (three vs. four)**

Helping You Remember

14. Draw an example of each figure. **See students' work.**
- | | | | | |
|-------|---------|------|----------|--------|
| prism | pyramid | cone | cylinder | sphere |
|-------|---------|------|----------|--------|

14-5 Study Guide and Intervention
Volume of Rectangular Prisms

The amount of space inside a three-dimensional figure is the volume of the figure. Volume is measured in **cubic units**. This tells you the number of cubes of a given size it will take to fill the prism.

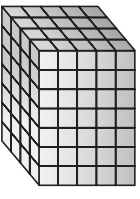

cubic unit

The volume V of a rectangular prism is the product of its length ℓ , width w , and height h .

Symbols $V = \ell wh$

You can also multiply the area of the base B by the height h to find the volume V .

Symbols $V = Bh$

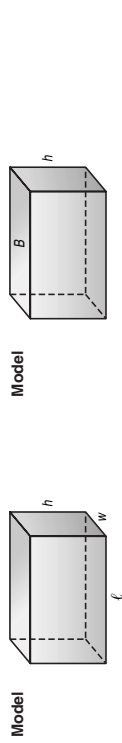

EXAMPLE 1 Find the volume of the rectangular prism.

Method 1 Use $V = \ell wh$.
 $V = \ell wh$
 $V = 10 \times 5 \times 2$
 $V = 100$
 The volume is 100 ft^3 .

Method 2 Use $V = Bh$.
 $V = Bh$
 $V = 50 \times 2$
 $V = 100$
 The volume is 100 ft^3 .

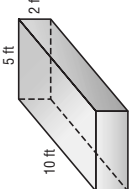

EXERCISES

Find the volume of each figure. Round to the nearest tenth if necessary.

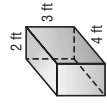
- 

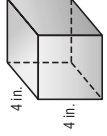
24 ft^3
- 

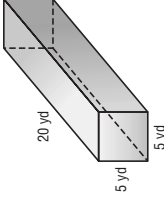
64 in^3
- 

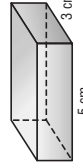
500 yd^3
- 

22.5 cm^3

14-5 Practice: Skills
Volume of Rectangular Prisms

Find the volume of each rectangular prism. Round to the nearest tenth if necessary.

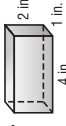
- 

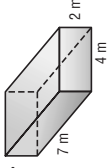
8 in^3
- 

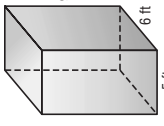
56 m^3
- 

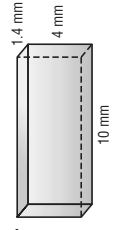
270 ft^3
- 

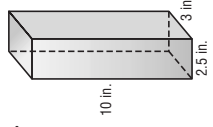
56 mm^3
- 

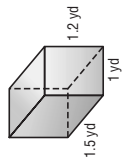
75 in^3
- 

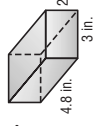
1.8 yd^3
- 

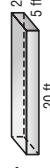
28.8 in^3
- 

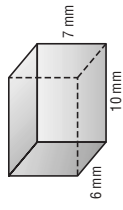
200 ft^3
- 

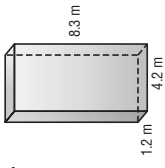
420 mm^3
- 

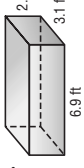
41.8 m^3
- 

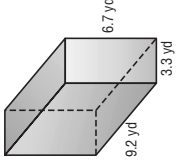
47.1 ft^3
- 

203.4 yd^3

13. Find the volume of a rectangular prism with length 9 meters, width 4 meters, and height 5 meters. **180 m^3**

14. What is the volume, to the nearest tenth, of a rectangular prism with length 6.2 yards, width 2.6 yards, and a height of 1.5 yards? **24.2 yd^3**

14-5 Reading to Learn Mathematics
Volume of Rectangular Prisms

Pre-Activity Complete the Mini Lab at the top of page 570 in your textbook. Write your answers below.

- What are the dimensions of the prism?
4 units by 3 units by 6 units
- Estimate how many of each group of cubes it will take to fill the prism. Assume that a group of cubes can be taken apart to fill the prism.
Group A: 10, Group B: 24, Group C: 18
- Use grid paper and tape to construct the prism. Then use centimeter cubes to find out how many of each group of cubes it will take to fill the prism. Compare the results to your estimates.
Group A: 9; Group B: 24; Group C: 18; the results should be close to the estimates.
- Describe the relationship between the number of centimeter cubes that it takes to fill the prism and the product of the dimensions of the prism.
The volume of the prism is equal to the product of the length, width, and height of the prism.

Reading the Lesson

Explain what each of the following formulas means.

- $V = \ell wh$ **The volume V of a rectangular prism is the product of its length ℓ and its width w and its height h .**
 - $V = Bh$ **The volume V of a rectangular prism is the product of the area of its base B and its height h .**
- Write the unit of measure for volume for each of the following.
- inch **in³**
 - foot **ft³**
 - centimeter **cm³**
 - meter **m³**

- Tell how a cubic meter is different from a cubic centimeter. **A cubic meter is a cube each of whose dimensions is one meter. A cubic centimeter is a cube each of whose dimensions is one centimeter.**
- Look at the formula and explanation at the top of page 571. Explain what the phrase rows of cubes means. **Sample answer: Each row of cubes is equal to the number of cubes needed to cover the base.**

Helping You Remember

- Take the measurements of a box and calculate its volume. Explain your answer. **See students' work.**

14-5 Practice: Word Problems
Volume of Rectangular Prisms

Find the volume to the nearest tenth if necessary.

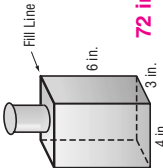
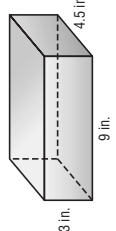
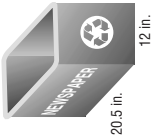
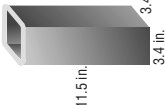
<p>1. OLYMPICS Olympic gold medal winner Ian Thorp competes in a pool with required dimensions 25 meters by 50 meters by 2 meters. What is the volume of the Olympic-sized pool? Explain how you found your answer. 2,500 m³; To find the volume, multiply length \times width \times height or first find the base, multiply length \times width \times height.</p>	<p>2. DUMP TRUCKS Raphaela drives a standard-sized dump truck. The dimensions of the bed of the truck are length 15 feet, width 8 feet, and height 6 feet. What is the volume of the bed of the dump truck? 720 ft³</p>
<p>3. GIFTS William has some antique bottles. He is going to fill the bottles with bath soap and give them away as gifts. Use the figure to find the volume up to the fill line of a bottle.</p>  <p>72 in³</p>	<p>4. JEWELRY Janine keeps her jewelry in a jewelry box like the figure below. Find the volume of Janine's jewelry box.</p>  <p>121.5 in³</p>
<p>5. RECYCLING The town of Riverview provides a rectangular recycling bin for newspapers to each household. What is the greatest volume of newspapers the recycling bin can hold?</p>  <p>3,936 in³</p>	<p>6. CANDLE MAKING Kyle will fill the candle mold with liquid candle wax. Find the amount of liquid wax that will be contained in the mold. Explain how you found your answer.</p>  <p>132.9 in³; To find the volume, multiply length, width, and height, $3.4 \times 3.4 \times 11.5$ or first find the base, 3.4×3.4, and then multiply by the height, 11.5 in.</p>

14-5 Enrichment

Volume and Liquid Capacity

The volume of a three-dimensional figure is the amount of space it contains. Volume is measured in cubic units—cubic meters, cubic inches, and so on.

The liquid capacity of a container is the amount of liquid it can hold. Liquid capacity generally is measured in units like liters, milliliters, cups, pints, quarts, and gallons.

The chart at the right shows the relationship between volume and liquid capacity. If a container were shaped like the rectangular prism below the chart, this is how you would find its liquid capacity.

Volume and Liquid Capacity
Metric
1 cm ³ = 1 mL
1 m ³ = 1,000 L
Customary
1 in. ³ ≈ 0.544 fl oz
1 ft. ³ ≈ 7.481 gal

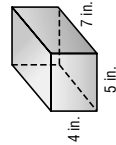

Volume

$$V = \ell wh$$

$$V = 7 \times 5 \times 4$$

$$V = 140$$

Liquid Capacity

$$1 \text{ in.}^3 \approx 0.544 \text{ fl oz}$$

$$140 \text{ in.}^3 \approx (140 \times 0.544) \text{ fl oz}$$

$$140 \text{ in.}^3 \approx 76.16 \text{ fl oz}$$

So the liquid capacity of the container is about 76 fluid ounces.

For Exercises 1–4, find the liquid capacity of a container shaped like a rectangular prism with the given dimensions. If necessary, round to the nearest whole number.

- length, 8 cm
width, 4 cm
height, 6 cm **192 mL**
- length, 7 ft
width, 2 ft
height, 3 ft **314 gal**
- length, 3.5 m
width, 1.5 m
height, 5 m **26,250 L**
- length, 5 in.
width, $1\frac{1}{2}$ in.
height, $3\frac{1}{2}$ in. **14 fl oz**

5. An aquarium is 36 inches long, 18 inches wide, and 18 inches tall. It is filled with water to a height of 12 inches. How many gallons of water are in the aquarium? (Round to the nearest gallon.) **34 gal**

6. CHALLENGE How many cubic inches of space are occupied by one quart of water? Round to the nearest whole number. **59 in³**

14-6 Study Guide and Intervention

Surface Area of Rectangular Prisms

The surface area S of a rectangular prism with length ℓ , width w , and height h is the sum of the areas of the faces.

Symbols $S = 2\ell w + 2\ell h + 2wh$

Model

EXAMPLE 1 Find the surface area of the rectangular prism.

Find the area of each face.

top and bottom

$$2(\ell w) = 2(8 \times 5) = 80$$

front and back

$$2(\ell h) = 2(8 \times 3) = 48$$

two sides

$$2(wh) = 2(5 \times 3) = 30$$

Add to find the surface area. The surface area is $80 + 48 + 30$ or 158 square meters.

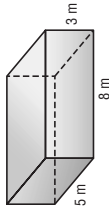

EXERCISES

Find the surface area of each rectangular prism. Round to the nearest tenth if necessary.

- 24 in²**
- 34 cm²**
- 160 ft²**
- 57.6 m²**
- 286.4 in²**
- 96 yd²**

NAME _____ DATE _____ PERIOD _____

14-6 Practice: Word Problems

Surface Area of Rectangular Prisms

For Exercises 1-6, round each surface area to the nearest tenth if necessary.

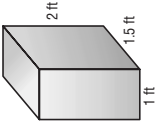
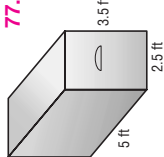
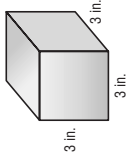
<p>1. GIFTS Fatima is wrapping a gift box for her nephew's birthday. The box's dimensions are 16 inches long by 10 inches wide by 5 inches high. What is the surface area of the box? 580 in²</p>	<p>2. FOOD Antoine is wrapping a block of cheese that is 22 centimeters long by 6.5 centimeters high by 10 centimeters wide with plastic wrap. What is the surface area of the cheese block? 856 cm²</p>
<p>3. PAINTING Kyle is painting the front door of his house. The dimensions of the door are 80 inches by 30 inches by 2 inches. If he paints all of the surfaces, how much area will he paint? Explain. 5,240 in². He will paint the outside face and the inside face of the door $2(80 \times 30)$, the two sides $2(80 \times 2)$, and the top and bottom $2(30 \times 2)$.</p>	<p>4. CARPENTRY Bryan is sanding a set of speaker boxes that he built for his room. What is the surface area of each box? 13 ft²</p> 
<p>5. CARPENTRY Cindy is putting oak veneer (thin wood covering) on the entire surface of her hope chest. How much veneer will she need? 77.5 ft²</p> 	<p>6. TOY MAKING Trey is covering blocks of wood with wallpaper to make building blocks for his baby sister. If he covers all the surfaces, how much wallpaper will he need? Think of a short way to solve this problem and explain. 54 in²; Sample answer: Since a cube has 6 equal faces, you can multiply the area of one face by 6, $6(3 \times 3)$.</p> 

NAME _____ DATE _____ PERIOD _____

14-6 Practice: Skills

Surface Area of Rectangular Prisms

Find the surface area of each rectangular prism. Round to the nearest tenth if necessary.

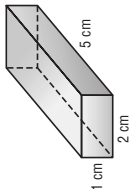
- 

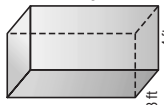
34 cm²
- 

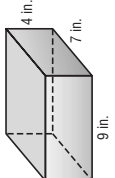
136 ft²
- 

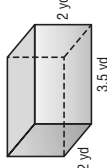
254 in²
- 

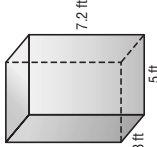
36 yd²
- 

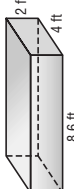
145.2 ft²
- 

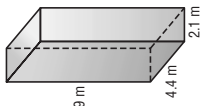
119.2 ft²
- 

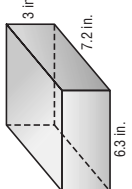
135.5 m²
- 

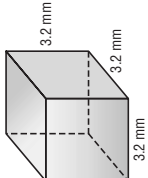
171.7 in²
- 

61.4 mm²
- 10.** Find the surface area of a rectangular prism that is $3\frac{1}{2}$ feet by $4\frac{1}{4}$ feet by 6 feet.
122 $\frac{3}{4}$ ft²
- 11.** What is the surface area of a rectangular prism that measures $2\frac{1}{3}$ meters by $2\frac{1}{2}$ meters by 4 meters?
50 $\frac{1}{3}$ m²

NAME _____ DATE _____ PERIOD _____

14-6 Reading to Learn Mathematics

Surface Area of Rectangular Prisms

Pre-Activity Complete the Mini Lab at the top of page 575 in your textbook. Write your answers below.

- Find the area of each face of the prism. **top: 15 cm²; bottom: 15 cm²; front: 24 cm²; back: 24 cm²; side: 40 cm²; side: 40 cm²**
- What is the sum of the areas of the faces of the prism? **158 cm²**
- What do you notice about the area of opposite sides of the prism? How could this simplify finding the sum of the areas? **Opposite sides have the same dimensions. So, find the area of each unique shape and multiply it by 2. Then add to find the total.**

Lesson 14-6

Reading the Lesson

- Describe in words each step shown for finding the surface area of a rectangular prism.
 $S = 2lw + 2lh + 2wh$
 $S = 2(17 \times 5) + 2(17 \times 6) + 2(5 \times 6)$
 $S = 2(85) + 2(102) + 2(30)$
 $S = 170 + 204 + 60$
 $S = 434$
- What is the unit of measure for surface area? **units²**
- What is the difference between a rectangular prism and a net of the prism? **Sample answer: A rectangular prism is a three-dimensional figure. A net of the prism is a two-dimensional representation of the area of each of the faces of the prism.**
- What is the difference between the surface area of a rectangular prism and the volume of the prism? **Sample answer: The surface area is the sum of the areas of each of the faces of the prism and is measured in units². The volume is the space within the prism. It is found by multiplying length times height times width (or depth) and is measured in units³.**

Helping You Remember

- Using a net, demonstrate that the surface area of a rectangular prism is equal to $2lw + 2lh + 2wh$. **See students' work.**

NAME _____ DATE _____ PERIOD _____

14-6 Enrichment

Nets

A net is a two-dimensional pattern that can be folded to form a three-dimensional figure. For example, the figure at the right is a net for a rectangular prism.

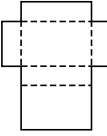

Answers (Lesson 14-6)

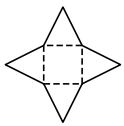

1.

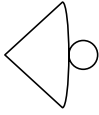

2.

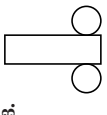

3.

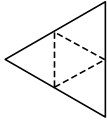

4.

square pyramid **cone**

cylinder

triangular pyramid

A cube is a rectangular prism in which all the edges have the same length. A net for a cube is made up of six squares. However, not every pattern of six squares is a net for a cube. For example, it would be impossible to fold the pattern at the right to form a cube.

Tell whether each of these patterns is a net for a cube.

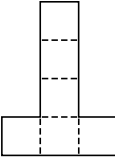

5. **yes**

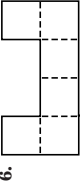

6. **no**

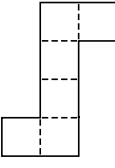

7. **yes**

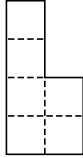

8. **no**

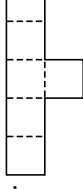

9. **no**

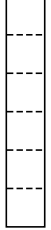

10. **no**

11. CHALLENGE In all, there are eleven different patterns of six squares that form a net for a cube. Sketch the eleven patterns in the space below.

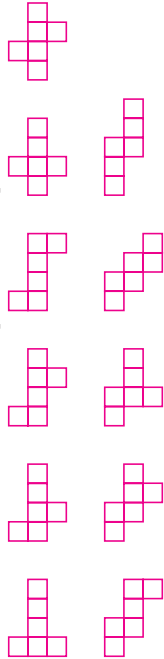

Chapter 14 Assessment Answer Key

Form 1
Page 729

1. A

2. G

3. D

4. H

5. C

6. G

7. A

8. G

9. D

10. I

Page 730

11. A

12. F

13. B

14. G

15. B

16. G

17. C

18. I

19. C

20. H

B: 9 in²

Form 2A
Page 731

1. A

2. H

3. C

4. G

5. D

6. F

7. B

8. H

9. C

10. G
(continued on the next page)

Chapter 14 Assessment Answer Key

Form 2A (continued)
Page 732

11. D

12. G

13. D

14. F

15. B

16. G

17. C

18. G

19. B

20. G

B: 56 ft²

Form 2B
Page 733

1. C

2. F

3. D

4. H

5. B

6. I

7. A

8. I

9. B

10. F

Page 734

11. D

12. H

13. A

14. F

15. C

16. H

17. D

18. H

19. C

20. F

B: 34 ft²

Chapter 14 Assessment Answer Key

Form 2C

Page 735

Page 736

1. 21 units²

2. 70 ft²

3. 21.4 cm²

4. $36\frac{2}{3}$ yd²

5. 135 cm²

6. 30.9 m²

7. 21 in²

8. 78.5 yd²

9. 171.9 ft²

10. 283.4 cm²

11. 50.2 in²

12. cylinder

13. triangular pyramid

14. 8

15. 336 m³

16. 575 in³

17. 592 ft²

18. 77.5 cm²

19. 9 ft³

20. 45 ft²

B: 34 ft²

Chapter 14 Assessment Answer Key

Form 2D
Page 737

Page 738

1. $\frac{27 \text{ units}^2}{80 \text{ ft}^2}$

3. 21.4 cm^2

4. $25\frac{2}{3} \text{ yd}^2$

5. 105 cm^2

6. 21.8 m^2

7. 27 in^2

8. 50.2 yd^2

9. 120.7 m^2

10. 226.9 cm^2

11. 28.3 in^2

12. sphere

13. triangular prism

14. 6

15. 504 m^3

16. 862.5 in^3

17. 556 ft^2

18. 101.5 cm^2

19. 12 ft^3

20. 58 ft^2

B: 52 ft^2

Chapter 14 Assessment Answer Key

Form 3
Page 739

1. 322 ft²

2. 107.6 cm²

3. 4 $\frac{1}{4}$ yd²

4. 135 in²

5. 30.9 m²

6. 7 in.

7. 1,962.5 ft²

8. 295.4 km²

9. 16.6 cm²

10. 10.3 yd²

11. Sample answer:
cone and cylinder



Page 740

12. It has 5 vertices,
8 edges, and 5 faces.



13. 2 vertices

14. 37 $\frac{1}{2}$ yd³

15. 25,875 in³

16. 40 in.

17. 695 ft²

18. 176 yd²

19. 271 in²

false; Sample answer:
Consider the
counterexample of a
2 by 2 by 1 box and
a 4 by 1 by 1 box.
Both have a volume of
20. 4 cubic units, but the
surface area of the
first is 16 square units
while the surface area
of the second is
18 square units.

B: $\frac{1}{6}$ in.

Chapter 14 Assessment Answer Key

Page 741, Extended Response Assessment Scoring Rubric

Level	Specific Criteria
4	The student demonstrates a thorough understanding of the mathematics concepts and/or procedures embodied in the task. The student has responded correctly to the task, used mathematically sound procedures, and provided clear and complete explanations and interpretations. The response may contain minor flaws that do not detract from the demonstration of a thorough understanding.
3	The student demonstrates an understanding of the mathematics concepts and/or procedures embodied in the task. The student's response to the task is essentially correct with the mathematical procedures used and the explanations and interpretations provided demonstrating an essential but less than thorough understanding. The response may contain minor errors that reflect inattentive execution of the mathematical procedures or indications of some misunderstanding of the underlying mathematics concepts and/or procedures.
2	The student has demonstrated only a partial understanding of the mathematics concepts and/or procedures embodied in the task. Although the student may have used the correct approach to obtaining a solution or may have provided a correct solution, the student's work lacks an essential understanding of the underlying mathematical concepts. The response contains errors related to misunderstanding important aspects of the task, misuse of mathematical procedures, or faulty interpretations of results.
1	The student has demonstrated a very limited understanding of the mathematics concepts and/or procedures embodied in the task. The student's response to the task is incomplete and exhibits many flaws. Although the student has addressed some of the conditions of the task, the student reached an inadequate conclusion and/or provided reasoning that was faulty or incomplete. The response exhibits many errors or may be incomplete.
0	The student has provided a completely incorrect solution or uninterpretable response, or no response at all.

Chapter 14 Assessment Answer Key

Page 741, Extended Response Assessment Sample Answers

In addition to the scoring rubric found on page A23, the following sample answers may be used as guidance in evaluating open-ended assessment items.

1.
 - a. She needs 15 in^2 fabric. You can find the area of the triangle by using $A = \frac{1}{2}bh$. Multiply the base 5 by the height 6 and divide by 2.
 - b. She needs 375 in^2 fabric. You can find the area of the parallelogram by using $A = bh$. Multiply the base 25 by the height 15.
 - c. She needs about 50.2 in^2 fabric. You can find the area of the circle by using $A = \pi r^2$. Square the radius 4 and multiply by π .
2.
 - a. This is a rectangular prism because it has four lateral faces that are rectangles and its bases are rectangles.
 - b. This is a cone because it has only one base, which is a circle, and has one vertex.
 - c. This is a triangular pyramid because it has only one base, which is a triangle and has three lateral faces that are triangles.
 - d. This is a sphere because it has no faces, bases, edges, or vertices.
- e. This is a cube or square prism because it has 6 faces and all faces are squares.
 - f. This is a square pyramid because it has lateral faces that are triangles and a base that is a square.
 - g. This is a cylinder because it has only two bases and these are circles, and it has no vertices.
 - h. This is a triangular prism because it has at least three lateral faces that are rectangles and its bases are triangles.
3.
 - a. She will need 158 in^2 to cover the box. You can find this by using $S = 2lw + 2lh + 2wh$. The total surface area = the area of the top + the area of the bottom + the area of the front + the area of the back + the area of one side + the area of the other side.
 $S = 2(8 \times 3) + 2(8 \times 5) + 2(3 \times 5)$.
 - b. The volume of the box is 120 in^3 . You can find the volume by using $V = \ell wh$, or $8 \times 3 \times 5$.

Chapter 14 Assessment Answer Key

Vocabulary Test/Review Page 742

1. f
2. a
3. h
4. i
5. b
6. g
7. j
8. d
9. e
10. c
11. a three-dimensional figure that has at least three lateral faces that are triangles and only one base

Quiz (Lessons 14-1 and 14-2) Page 743

1. 28 in²
2. 63.1 in²
3. 15 $\frac{1}{8}$ yd²
4. 54 in²
5. B

Quiz (Lessons 14-3) Page 743

1. 50.2 ft²
2. 226.9 cm²
3. 162.8 m²
4. 2.0 m²
5. 78.5 mi²

Quiz (Lessons 14-4 and 14-5) Page 744

1. square pyramid
2. cone
Sample answer:
an unsharpened pencil
3. 168 in³
5. Yes; the volume of the container is 192 cubic inches, which is greater than the 86.63 cubic inches Jian requires.

Quiz (Lesson 14-6) Page 744

1. 108 yd²
2. 66.7 cm²
3. 54 in²
4. 472 ft²
5. 12 ft²

Chapter 14 Assessment Answer Key

Mid-Chapter Test Page 745

1. C
2. I
3. B
4. 22.1 cm²
5. 17.8 yd²
6. 45 ft²
7. 22.1 m²
8. 201.0 yd²
9. 40.7 m²
10. 176.6 cm²

Cumulative Review Page 746

1. $2 \times 3 \times 3 \times 7$
2. 10 and 12
3. 22.45
4. $\frac{1}{3}$
5. $3\frac{11}{20}$
6. 18
7. rule: $y = x + 3$

input (x)	output (y)
-5	-2
-2	1
0	3

Sample answer:

8. $\frac{1}{2} \times 600 = 300$
9. meter
10. 68°

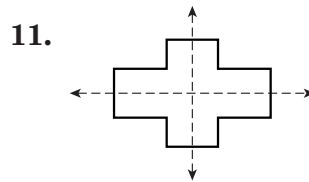

12. $\frac{1}{2}$, 0.5, or 50%
13. about 2,826 in²
14. 136 in²

Chapter 14 Assessment Answer Key

Standardized Test Practice

Page 747

Page 748

1. A B C D

2. F G H I

3. A B C D

4. F G H I

5. A B C D

6. F G H I

7. A B C D

8. F G H I

9. A B C D

10. F G H I

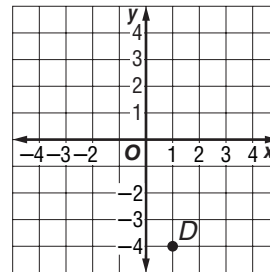

11.

12.

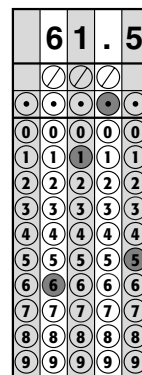

13.

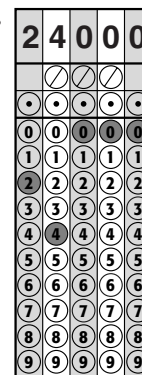

14. 28.26 ft²

15. a.

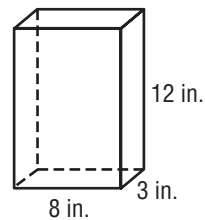

b. 86 in³

c. No; the volume would be 192 in³, not enough to hold the 202 cubic inches of cereal.

d. 44 in²

Answers

Chapter 14 Assessment Answer Key

Unit 6 Test

Page 749

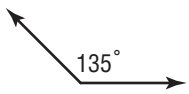
1. $2\frac{1}{8}$ in.
2. 5.4 cm; 54 mm
3. 5
4. 20,000
5. 0.058
6. 24
7. millimeter
8. meter
9. kilogram; Sample answer: 10 kg
10. milliliter; Sample answer: 400 mL
11. 5 h 58 min 7 s
12. 5 h 56 min
13. 133°
14. 50° ; acute
15. 180° ; straight
16. 145° ; obtuse
17. about 30°
18. 
19. hexagon; regular
20. quadrilateral; not regular

Page 750

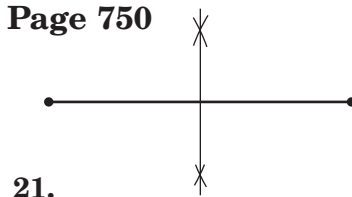

21.

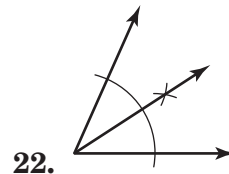

22.

23. similar

24. neither

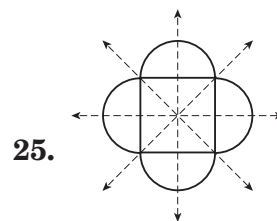

25.

26. yes

27. $22\frac{1}{2}$ cm²

28. 44 in²

29. 33.2 cm²

30. cylinder

31. rectangular pyramid

32. square prism or cube

33. 42 ft³

34. 121.5 in²

Chapter 14 Assessment Answer Key

Second Semester Test

Page 751

1. B

2. G

3. C

4. G

5. D

6. F

7. B

8. H

9. A

Page 752

10. I

11. D

12. G

13. C

14. I

15. B

16. I

17. C

18. F

(continued on the next page)

Chapter 14 Assessment Answer Key

Second Semester Test (continued)

Page 753

19. -9
20. 7
21. -6

22. 18
23. -5
24. $5 \times (60 + 7) = 5(60) + 5(7) = 300 + 35 = 335$

25. -1
26. 10
27. -3
28. 4
29. $\frac{9}{11}$

30. 4.2
31. $2\frac{1}{2}$
32. 0.37
33. 111.39
34. Sample answer:
 $\frac{3}{4} \times 120 = 90$

35. $\frac{1}{4}$, 0.25, 25%
36. $\frac{7}{12}$, $0.58\bar{3}$, or $58.\bar{3}\%$
37. $\frac{1}{12}$, $0.08\bar{3}$, or $8.\bar{3}\%$

38. 25

Page 754

39. $\frac{1}{3}$, $0.\bar{3}$, or $33.\bar{3}\%$

40. 30

41. kilogram; Sample
 answer: 2 kg
42. milliliter; Sample
 answer: 80 mL

43. 2
44. 24,000
45. 130° ; obtuse

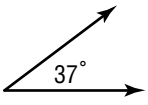
46. 
47. pentagon; not
 regular

48. $17\frac{1}{2}$ yd²
49. 13.8 cm²

50. 52.5 ft³

Chapter 14 Assessment Answer Key

Final Test
Page 755

1. C

2. G

3. B

4. I

5. C

6. G

7. C

8. G

9. D

10. I

11. C

12. H

Page 756

13. A

14. I

15. A

16. I

17. A

18. H

19. D

20. H

21. A

22. I

(continued on the next page)

Chapter 14 Assessment Answer Key

Final Test (continued)

Page 757

23. D

24. G

25. C

26. I

27. A

28. G

29. A

30. G

31. C

32. F

33. C

Page 758

34. $2 \times 3 \times 11$

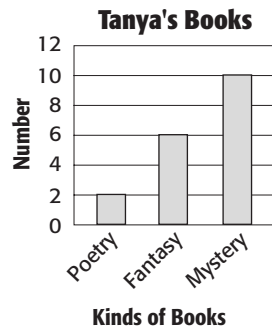

35.

36. $\frac{4}{9}$, $0.\bar{4}$, or $44.\bar{4}\%$

37. 74%

Stem	Leaf
1	2 9
2	8
3	2 3 3
4	0 5

38. $3|2 = 32$

39. 1.375, 1.44, 1.5, 2.5, 8.4

40. 1.06

41. 49.28 m

42. 36.4 ft

43. 1.968

44. 7.75

45. -24

46. 7

47. 16

48. 0.1875

49. $0.\bar{13}$

(continued on the next page)

Chapter 14 Assessment Answer Key

Final Test (continued)

Page 759

50. $9\frac{5}{12}$

51. $5\frac{5}{12}$

52. $1\frac{1}{8}$

53. $4\frac{1}{2}$

54. $\frac{4}{7}$

55. Sample answer:
 $\frac{3}{8} \times 72 = 27$

56. $-6, -2, 0, 3, 5$

57. -7

58. 9

59. $-6, -3, 3$

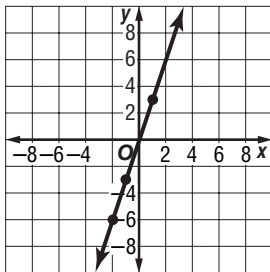

60. $\frac{\$0.25}{1 \text{ bottle}}$

61. 52.5%

62. 20.5%

63. 144

64. -3

65. 7

66. 10

67. $\frac{1}{4}, 0.25, 25\%$

68. $\frac{3}{8}, 0.375, \text{ or } 37.5\%$

Page 760

69. 90

70. $\frac{2}{3}, 0.\bar{6}, \text{ or } 66.\bar{6}\%$

71. $2\frac{5}{8} \text{ in.}$

72. $6.7 \text{ cm; } 67 \text{ mm}$

73. milliliter; Sample answer: 250 mL

74. $5 \text{ h } 6 \text{ min } 18 \text{ s}$

75. similar

76. pentagon; no

77. yes

78. 2 lines

79. 348 ft^2

80. $8\frac{1}{3} \text{ cm}^2$

